

TECHNICAL MANUAL
UNIT MAINTENANCE MANUAL
FOR
TRACTOR, WHEELED, 4 X 4 DED
SMALL EMPLACEMENT EXCAVATOR (SEE)
(NSN 2420-01-160-2754) (EIC:EDL)

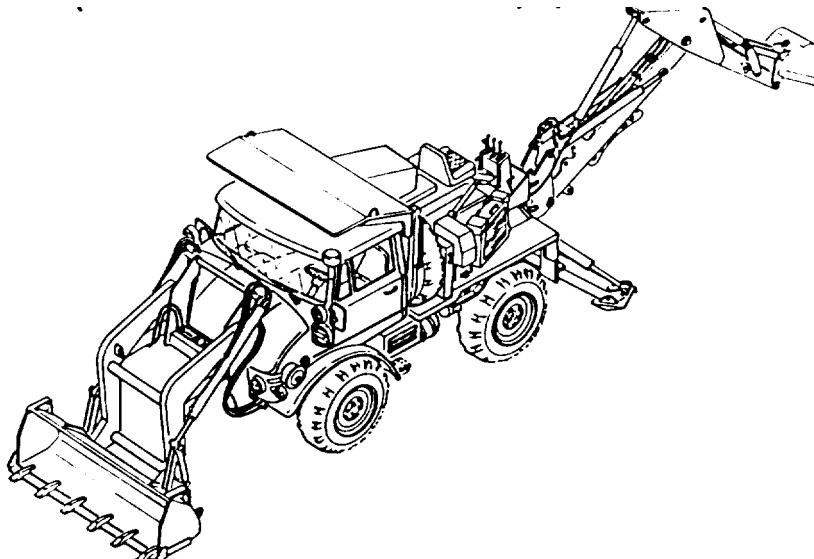

TRACTOR, WHEELED, 4 X 4 DED
HIGH MOBILITY MATERIAL HANDLER (HMMH)
(NSN 2420-01-205-8636)

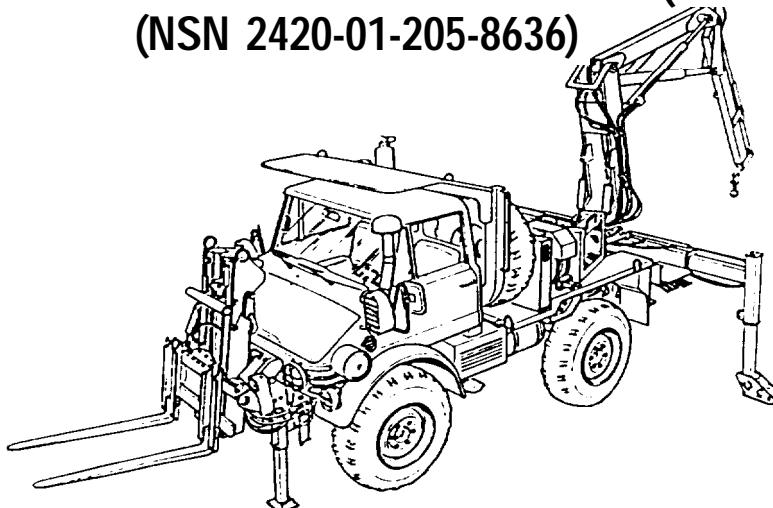

TABLE OF CONTENTS	i
HOW TO USE THIS MANUAL	xii
EQUIPMENT DESCRIPTION AND DATA	1-3
PREVENTIVE MAINTENANCE CHECKS AND SERVICES	2-2
TROUBLESHOOTING	3-1
INDEX	Index-1

WARNING

CARBON MONOXIDE POISONING CAN BE DEADLY

CARBON MONOXIDE IS A COLORLESS, ODORLESS, DEADLY POISONOUS GAS, WHICH, WHEN BREATHED, DEPRIVES THE BODY OF OXYGEN AND CAUSES SUFFOCATION. EXPOSURE TO AIR CONTAMINATED WITH CARBON MONOXIDE PRODUCES SYMPTOMS OF HEADACHE, DIZZINESS, LOSS OF MUSCULAR CONTROL, APPARENT DROWSINESS, OR COMA. PERMANENT BRAIN DAMAGE OR DEATH CAN RESULT FROM SEVERE EXPOSURE.

CARBON MONOXIDE OCCURS IN THE EXHAUST FUMES OF FUEL-BURNING HEATERS AND INTERNAL-COMBUSTION ENGINES AND BECOMES DANGEROUSLY CONCENTRATED UNDER CONDITIONS OF INADEQUATE VENTILATION. THE FOLLOWING PRECAUTIONS MUST BE OBSERVED TO ENSURE THE SAFETY OF PERSONNEL WHENEVER THE PERSONNEL HEATER, MAIN, OR AUXILIARY ENGINE OF ANY VEHICLE IS OPERATED FOR MAINTENANCE PURPOSES OR TACTICAL USE:

1. DO NOT operate engine of vehicle in an enclosed area unless it is ADEQUATELY VENTILATED.
2. DO NOT idle engine for long periods without maintaining ADEQUATE VENTILATION in the personnel compartments.
3. DO NOT drive any vehicle with inspection plates, cover plates, or engine compartment doors removed unless necessary for maintenance purposes.
4. BE ALERT. at all times during vehicle operation for exhaust odors and exposure symptoms. If either is present, IMMEDIATELY VENTILATE personnel compartments. If symptoms persist, remove affected personnel from vehicle and treat as follows: expose to fresh air; keep warm, DO NOT PERMIT EXERCISE; if necessary, administer artificial respiration (see FM 21-11).

THE BEST DEFENSE AGAINST CARBON MONOXIDE POISONING IS ADEQUATE VENTILATION.

WARNING

COMPRESSED AIR

To prevent injury, compressed air used for cleaning and drying purposes will not exceed 30 psi (207 kPa). Use only with effective chip guarding and personal protective equipment (goggles/shield, gloves, etc.).

WARNING

Drycleaning solvent P-D-680 is toxic and flammable. Wear protective goggles and gloves and use only in well-ventilated area. Avoid contact with skin, eyes, and clothes and do not breathe vapors. Do not use near open flame or excessive heat. Flash point is 100°-138° F (38°-50°C). If you become dizzy while using drycleaning solvent, get fresh air immediately and get medical aid. If contact with eyes is made, wash your eyes with water and get medical aid immediately.

WARNING

Remove rings, bracelets, wristwatches, and neck chains before working on vehicle. Jewelry can catch on equipment and cause injury, or may short across an electrical circuit and cause severe burns or electrical shock.

WARNING

Diesel fuel is flammable. Do not perform this procedure near fire, flame, or sparks. Injury or death to personnel could result.

WARNING

Do not connect or disconnect any electrical connector unless vehicle MASTER disconnect switch is OFF. To do so could result in injury to personnel.

WARNING

Do not disconnect any air system lines or fittings unless vehicle engine is shut off and air system pressure is relieved. To do so could result in injury to personnel.

W A R N I N G

All vehicle electrical switches must be OFF before disconnecting battery cables. Failure to do so could result in injury to personnel.

W A R N I N G

High pressure hydraulics [oil under 2450 psi (16,893 kPa)] operate this equipment. Never disconnect any hydraulic line or fitting without first dropping pressure to zero. A high pressure oil stream can pierce body and cause severe injury to personnel.

W A R N I N G

If NBC exposure is suspected, all air filter media should be handled by personnel wearing protective equipment. Consult your unit NBC Officer or NBC NCO for appropriate handling or disposal instructions.

W A R N I N G

Never use gasoline to clean parts. Gasoline is highly flammable. Serious personal injury could result if fuel ignites during cleaning.

W A R N I N G

Prior to initial use, new, extensively repaired, or altered forklift or crane must be load tested to prevent injury to personnel.

W A R N I N G

Steam cleaning creates hazardous noise levels and severe burn potential. Eye, skin, and ear protection are required.

W A R N I N G

Solvents used with spray gun must be used in spray booth with filter. Face shield must be used by personnel operating spray gun. Failure to do so could result in serious injury to personnel.

W A R N I N G

Drilling and grinding operations are hazardous to the eyes. Eye protection is required.

W A R N I N G

On direct contact, uncured silicone sealant irritates eyes. In case of contact, flush eyes with water and seek medical attention. Avoid prolonged contact with skin.

W A R N I N G

Before starting engine, make sure all personnel are clear of engine. Failure to do so could result in injury to personnel.

W A R N I N G

When replacing fuses, make sure only fuses of correct amperage are installed. Failure to do so could result in injury to personnel or damage to equipment.

Technical Manual
No. 5-2420-224-20-1

HEADQUARTERS
DEPARTMENT OF THE ARMY
Washington D. C., 28 July 1993

UNIT MAINTENANCE MANUAL
FOR
TRACTOR, WHEELED, 4 X 4 DED
SMALL EMPLACEMENT EXCAVATOR (SEE)
(NSN 2420-01-160-2754) (EIC:EDL)

AND

TRACTOR, WHEELED, 4 X 4 DED
HIGH MOBILITY MATERIAL HANDLER (HMMH)
(NSN 2420-01-205-8636)

VOLUME 1 OF 2

REPORTING ERRORS AND RECOMMENDING IMPROVEMENTS

You can help improve the manual. If you find any mistakes or if you know of a way to improve the procedures, please let us know. Mail your letter, DA Form 2028 (Recommended Changes to Publications and Blank Forms) or DA Form 2028-2 located in the back of this manual, direct to: Commander, U.S. Army Tank Automotive Command, Attn: AMSTA-MB, Warren, MI 48397-5000. A reply will be furnished to you.

TABLE OF CONTENTS

VOLUME 1

	Page
	LIST OF TASKS iii
	<u>HOW TO USE THIS MANUAL</u> xii
CHAPTER 1	INTRODUCTION
Section I	General Information 1-1
Section II	<u>Equipment Description and Data</u> 1-3
Section III	Principles of Operation 1-8
CHAPTER 2	SERVICES AND SCHEDULED VEHICLE MAINTENANCE
Section I	Repair Parts, Special Tools; Test, Measurement, and Diagnostic Equipment (TMDE); and Support Equipment 2-1
Section II	<u>Service Upon Receipt</u> 2-2
Section III	<u>Preventive Maintenance Checks and Services</u> 2-2

This manual along with TM5-2420-224-20-2 and TM5-2420-224-34 supersedes

TM5-2420-224-24 dated December 1989

Approved for public release; distribution unlimited

TABLE OF CONTENTS (CONT)

	Page
Section IV	Painting and Restenciling Markings 2-14
Section V	General Repair and Cleaning Methods 2-15
Section VI	General Hydraulic System Repair Methods 2-32
Section VII	Preparation for Storage or Shipment 2-36
CHAPTER 3	<u>TROUBLESHOOTING</u>
Section I	Using Electrical Test Equipment 3-1
Section II	Wiring Harness and Wire Repair. 3-11
Section III	Using STE/ICE-R with the Tractor 3-17
Section IV	Troubleshooting Procedures 3-63
	INDEX Index-1
VOLUME 2	
CHAPTER 4	VEHICLE MAINTENANCE INSTRUCTIONS 4-1
Section I	Power Package Maintenance 4-2
Section II	Clutch Maintenance 4-12
Section III	Fuel System Maintenance 4-24
Section IV	Exhaust System Maintenance 4-79
Section V	Cooling System Maintenance 4-86
Section VI	Electrical System Maintenance 4-109
Section VII	Transmission Maintenance 4-240
Section VIII	Front and Rear Axles Maintenance 4-245
Section IX	Brake Maintenance 4-249
Section X	Wheel Maintenance 4-335
Section XI	Steering Maintenance 4-338
Section XII	Frame and Towing Attachments Maintenance 4-362
Section XIII	Springs and Shock Absorbers Maintenance 4-367
Section XIV	Body, Cab, and Hood Maintenance 4-384
Section XV	Body and Chassis Accessory Items Maintenance 4-474
Section XVI	Hydraulic System Maintenance 4-499
Section XVII	Gages (Non-Electrical) Maintenance 4-727
Section XVIII	Machine Tools and Related Equipment Maintenance 4-736
Section XIX	Cranes, Shovels, and Earthmoving Equipment Components Maintenance 4-751
APPENDIX A	REFERENCES A-1
APPENDIX B	MAINTENANCE ALLOCATION CHART B-1
APPENDIX C	EXPENDABLE SUPPLIES AND MATERIALS LIST C-1
APPENDIX D	ILLUSTRATED LIST OF MANUFACTURED ITEMS D-1
APPENDIX E	TORQUE LIMITS E-1
	INDEX Index-1

LIST OF TASKS

VOLUME 2

A list of the maintenance procedures included in this manual is shown below, and on the following pages. If more information is needed, refer to the Table of Contents or the Alphabetical Index.

POWER PACKAGE MAINTENANCE (Section I)

	Page
Valve Cover and Gasket Replacement	4-3
Valve Adjustment	4-5
Oil Separator Replacement	4-6
Engine Oil Filter Element and Bowl Replacement	4-7
Engine Oil Hose and Fittings Replacement	4-9
Engine Inlet and Outlet Air Lines Replacement	4-10

CLUTCH MAINTENANCE (Section II)

Clutch Pedal Replacement and Adjustment	4-13
Clutch Hydraulic Reservoir Replacement	4-15
Clutch Hydraulic Reservoir Lines and Fittings Replacement	4-17
Clutch Slave Cylinder Replacement	4-19
Clutch Slave Cylinder Adjustment.	4-21
Clutch Master Cylinder Replacement	4-22

FUEL SYSTEM MAINTENANCE (Section III)

Fuel Injector Lines Replacement.	4-25
Fuel Primer Pump Replacement.	4-29
Hand Primer Replacement	4-31
Air Cleaner Replacement	4-32
Air Cleaner Filter Elements Replacement	4-35
Air Cleaner Ducts Replacement.	4-38
Vertical Air Intake Pipe Replacement	4-39
Fuel Tank Draining	4-40
Fuel System Bleeding	4-41
Fuel Tank Replacement	4-42
Fuel Tank Lines and Fittings Replacement	4-44
Fuel Cap, Fittings, and Controls Replacement	4-47
Fuel Filter Element Replacement.	4-48
Fuel Filter Assembly Replacement and Repair	4-50
Fuel Filter Pre-Sediment Bowl and Filter Replacement	4-54
Cold Start Aid Replacement	4-55
Accelerator Pedal and Linkage Replacement	4-58
Accelerator Linkage Replacement	4-64
Accelerator Linkage Adjustment.	4-68
Hand Throttle Replacement	4-70
Air Cylinder Replacement (SEE)..	4-72
Air Cylinder Replacement (HMMH)	4-74
Air Cylinder Adjustment (SEE)...	4-76
Air Cylinder Adjustment (HMMH).	4-77

LIST OF TASKS (CONT)

EXHAUST SYSTEM MAINTENANCE (Section IV)

	Page
Muffler Replacement	4-80
Muffler Pipes and Clamps Replacement	4-81
Exhaust Manifold Screening Plate Replacement	4-85

COOLING SYSTEM MAINTENANCE (Section V)

Cooling System Service	4-87
Cooling System Test	4-89
Coolant Expansion Tank Filler Cap Pressure Test	4-90
Radiator Replacement	4-92
Coolant Expansion Tank Replacement	4-96
Coolant Expansion Tank Support Replacement	4-97
Coolant Hoses and Clamps Replacement	4-98
Coolant Thermostat Replacement.	4-100
Coolant Water Outlet Replacement.	4-101
Water Manifold and Gasket Replacement	4-102
Water Pump Replacement	4-104
Fan Impeller Replacement	4-105
Fan Belt Replacement	4-106
Fan Belt Adjustment	4-108

ELECTRICAL SYSTEM MAINTENANCE (Section VI)

Alternator and Alternator Bracket Replacement	4-112
Starter Replacement	4-117
Starter Solenoid Replacement	4-119
Polarity Breaker and Suppressor Filter Mounting Bracket Replacement	4-120
Polarity Breaker Replacement..	4-121
Turn Signal Lever Replacement..	4-122
Press-to-Test Switch Replacement	4-123
indicator (Gage) Replacement..	4-124
Tachometer Replacement	4-128
Ignition Switch Replacement	4-131
Windshield Wiper/Washer Switch Replacement	4-132
Starter Switch Replacement	4-133
Hazard Warning Switch Replacement	4-134
Ammeter Replacement	4-135
Cold Start Switch Replacement..	4-136
Master Light Switch Replacement	4-137
Instrument Cluster Panel Light Replacement	4-138
Windshield Heater Control Switch Replacement	4-139
Windshield Wiper/Washer Switch Relay Replacement	4-140
Warning Delay Relay Replacement	4-141
Hydraulic Suspension Lockout Controls Replacement	4-142
Auxiliary Light Control Switch Replacement	4-146
Hydraulic Oil Cooler Thermal Switch Replacement	4-147
Relay Replacement	4-150
Bucket and Auxiliary Throttle Switches Replacement	4-151
Throttle Control Switch Replacement (SEE)	4-154
Auxiliary Throttle Switch Replacement	4-156
Throttle Control Switch Replacement (HMMH)	4-158

LIST OF TASKS (CONT)

ELECTRICAL SYSTEM MAINTENANCE (Section VI)-CONT

	Page
Tool and Work Light Switches Replacement	4-162
Fuse Holder Replacement	4-166
Brake Light Diode Replacement.	4-168
Fuse Replacement	4-169
Low Oil Pressure and High Water Temperature Alarm Replacement	4-170
Main (Master) Disconnect Switch Replacement	4-171
Slave Receptacle Replacement	4-172
Headlight Replacement	4-173
Auxiliary Headlight Replacement.	4-175
Auxiliary Headlight Adjustment	4-179
Front Blackout Light Replacement and Repair	4-181
Front Composite Light Replacement and Repair	4-183
Work Light Replacement and Repair	4-186
Crane Mast Floodlight Replacement and Repair	4-188
Rear Composite Stoplight/Taillight Replacement and Repair	4-190
Dome Light Replacement	4-195
Turn Signal Flasher Relay Replacement	4-196
Engine Start Switch Replacement.	4-199
Brake Light Switch Replacement..	4-200
Starter Lockout/Intermediate Speed Shift Sending Unit Replacement	4-201
Oil Pressure Sender Replacement.	4-202
Water Temperature Sending Unit Replacement	4-203
Fuel Level Gage Replacement	4-204
Air Cleaner Restrictor Indicator Switch Replacement	4-205
Power Take-Off Indicator Switch Replacement	4-206
Differential Lock Indicator Switch Replacement	4-207
Backup Alarm Switch Replacement	4-208
Intermediate Speed Shift and Indicator Switch Replacement	4-209
Parking Brake Switch Replacement	4-210
STE/ICE-R Resistor Replacement.	4-211
STE/ICE-R Fuel Pressure Switch Replacement	4-212
STE/ICE-R Shunt Replacement.	4-213
Backup Alarm Replacement	4-214
Horn, Low Beam/High Beam Switch Replacement	4-215
Horn Replacement	4-218
Battery Replacement	4-219
Battery Cables Replacement	4-221
Battery Box Replacement	4-226
Battery Box Repair	4-228
Trailer Connection Replacement.	4-230
Front Disc Brake Pad Indicator Wiring Harness Replacement	4-231
Suppressor Filters Replacement..	4-235
Engine Temperature Switch Replacement	4-238

TRANSMISSION MAINTENANCE (Section VII)

All Wheel Drive Selector Valve Replacement	4-240
All Wheel Drive Pressure Regulator Replacement	4-242
All Wheel Drive Control Cylinder Replacement And Adjustment	4-243

LIST OF TASKS (CONT)

Page

FRONT AND REAR AXLES MAINTENANCE (Section VIII)

Axle Vent Hoses Replacement	4-245
Front Axle Final Drive Outer Seal Replacement	4-247
Rear Axle Final Drive Outer Seal Replacement	4-248

BRAKE MAINTENANCE (Section IX)

Parking Brake Controls Replacement	4-251
Parking Brake Adjustment	4-254
Brake Fluid Reservoir Replacement	4-257
Front Trailer Coupling Replacement	4-259
Protection/Relay Valve Replacement	4-261
Brake System Bleeding	4-262
Brake Disc and Hub Replacement	4-265
Rear Disc Brake Pad Replacement	4-268
Front Disc Brake Pad Replacement	4-271
Brake Caliper Replacement	4-274
Brake Master Cylinder Replacement	4-276
Rear Brake Calipers Hydraulic Lines and Fittings Replacement	4-278
Brake Master Cylinder Hydraulic Lines and Fittings Replacement	4-280
Brake Pressure Regulator (ALB Valve) Lines and Fittings Replacement	4-282
Front Brake Calipers Hydraulic Lines and Fittings Replacement	4-284
Brake Pedal Replacement	4-286
Brake Pedal Adjustment	4-287
Air Pressure Tanks Replacement	4-288
Air Brake Booster Replacement.	4-295
Antifreeze Reservoir Replacement	4-298
Antifreeze Device Replacement	4-300
Large Air Pressure Tank Overflow Valve and Fittings Replacement	4-302
Small Air Pressure Tank Overflow Valve and Fittings Replacement	4-303
Accessory Air Supply Overflow Valve and Fittings Replacement	4-304
Fluid Regulating Valve Replacement	4-306
Trailer Service Air Supply Lines and Fittings Replacement	4-307
Trailer Emergency Air Supply Lines and Fittings Replacement	4-310
Trailer Air Supply Valve Lines and Fittings Replacement	4-313
Air Pressure and Accessory Air Supply Lines and Fittings Replacement	4-315
Brake Booster and Air Pressure Lines and Fittings Replacement	4-318
Protection/Relay Valve Lines and Fittings Replacement	4-320
Tandem Valve Replacement	4-322
Air System Supply Lines and Fittings Replacement	4-324
Trailer Hand Brake Valve Replacement	4-326
Trailer Air Supply Lines and Fittings Replacement	4-327
Trailer Hand Brake Valve Lines and Fittings Replacement	4-329
Trailer Air Supply Valve Replacement	4-331
Tractor Protection Valve Replacement	4-332
Trailer Hand Brake Air Supply Lines and Fittings Replacement	4-333

WHEEL MAINTENANCE (Section X)

Wheel Assembly Replacement	4-335
Tire Replacement	4-337

LIST OF TASKS (CONT)

	Page
STEERING MAINTENANCE (Section XI)	
Tie Rod Replacement and Repair	4-338
Tie Rod Adjustment	4-341
Steering Wheel Replacement	4-343
Steering Wheel Bracket and Seal Replacement	4-344
Drag Link Replacement and Adjustment	4-346
Steering Arm Replacement	4-349
Steering Upper Shaft Bearing Replacement	4-351
Power Steering Gear Adjustment.	4-354
Power Steering Pump Belt Replacement and Adjustment	4-356
Power Steering Lines and Fittings Replacement	4-357
Power Steering Filter Element Replacement	4-359
Power Steering Tank (Reservoir) Replacement	4-360
FRAME AND TOWING ATTACHMENTS MAINTENANCE (Section XII)	
Backhoe Subframe Deck Replacement	4-362
Decontamination Mounting Bracket Replacement	4-363
Chassis Tool Box/Deck Plate Replacement	4-364
Pintle Assembly Replacement.	4-365
SPRINGS AND SHOCK ABSORBERS MAINTENANCE (Section XIII)	
Front Rubber Bumpers Replacement	4-367
Front Shock Absorbers Replacement (SEE)	4-368
Front Shock Absorbers Replacement (HMMH)	4-369
Rear Shock Absorbers Replacement	4-372
Front Control Arm Replacement.	4-374
Rear Control Arm Replacement.	4-375
Front Axle Torsion Bar Replacement	4-376
Rear Axle Torsion Bar Replacement	4-378
BODY, CAB, AND HOOD MAINTENANCE (Section XIV)	
Front Plate Replacement	4-385
Canopy (FOPS) Replacement	4-387
Outside Engine Hood Replacement	4-388
Inside Engine Hood Replacement	4-389
Spare Tire and Mount Replacement (SEE)	4-390
Spare Tire and Mount Replacement (HMMH)	4-391
Cab Door Replacement	4-392
Cab Door and Window Replacement and Repair	4-393
Backhoe Control Tower Replacement	4-404
Front Fender and Splash Guard Replacement	4-409
Splash Guard Replacement	4-412
Cab Door Seal Replacement	4-413
Cab Drain Plug Replacement	4-414
Cab Shock Absorbers and Mountings Replacement	4-415
Cab Tilt and Lower	4-418
Floor Platform Replacement	4-433
Operator Seat and Framework Replacement	4-437
Operator Seat Framework Repair	4-442
Backhoe Seat Replacement	4-444

LIST OF TASKS (CONT)

BODY, CAB, AND HOOD MAINTENANCE (Section XIV)-CONT

	Page
Backhoe Seat Repair	4-445
Passenger Seat and Framework Replacement	4-446
Seat Belt Replacement	4-451
Cab Floor Linings Replacement.. . . .	4-454
Sun Visor, Clothes Hook, and Grip Handles Replacement	4-455
Roof Liner Replacement	4-458
Hose Reel Assembly Replacement and Repair	4-459
Hose Reel Motor Spring Replacement	4-464
Hydraulic Accessory Box Replacement and Repair (SEE)	4-466
Hydraulic Accessory Box Replacement and Repair (HMMH)	4-468
Hydraulic Tool Hoses Replacement	4-471

BODY AND CHASSIS ACCESSORY ITEMS MAINTENANCE (Section XV)

Interior Rear View Mirror Replacement	4-475
Exterior Rear View Mirror Replacement	4-476
Windshield Wiper/Washer Motor Replacement	4-477
Windshield Wiper/Washer Motor Linkage Replacement	4-479
Windshield Wiper Replacement.. . . .	4-482
Windshield Washer Reservoir Replacement	4-483
Windshield Washer Pump Replacement	4-484
Defroster and Air Tubes Replacement	4-486
Heater Hoses and Clamps Replacement	4-488
Cab Heater Replacement	4-490
Data Plates Replacement	4-492

HYDRAULIC SYSTEM MAINTENANCE (Section XVI)

Front Hydraulic Pump Replacement	4-502
Rear Hydraulic Pump Replacement	4-504
Front Hydraulic Pump Belt Replacement and Adjustment	4-506
Hydraulic Suspension Lockout Filter Replacement	4-507
Crane Hydraulic Motor Replacement	4-509
Hydraulic Suspension Lockout Pump Replacement	4-511
Hydraulic Suspension Lockout Accumulator Replacement	4-516
Backhoe Swing Control Pedal Replacement	4-518
Backhoe Swing Control Pedal Adjustment	4-522
Backhoe Control Lever Replacement	4-523
Backhoe Control Rod Adjustment.	4-531
Front Loader/Forklift Control Valve Controls Replacement and Adjustment	4-532
Crane Controls and Linkages Replacement and Adjustment	4-538
Forklift Crosshead Replacement and Adjustment	4-541
Forklift Replacement	4-546
Forklift Rotator Replacement	4-555
Forklift Carriage Chain Adjustment	4-559
Forklift Mast Chain Adjustment	4-562
Forklift Forks Replacement	4-563
Forklift Travel Lock Replacement	4-566
Forklift Front Outrigger Replacement	4-567
Front Loader Hydraulic Relief Valve Replacement	4-568
Left Loader Boom Cylinder Hydraulic Lines and Fittings Replacement	4-569
Right Loader Boom Cylinder Hydraulic Lines and Fittings Replacement	4-572

LIST OF TASKS (CONT)

HYDRAULIC SYSTEM MAINTENANCE (Section XVI)-CONT

	Page
Left Loader Bucket Rollback Cylinder Hydraulic Lines and Fittings Replacement	4-574
Right Loader Bucket Rollback Cylinder Hydraulic Lines and Fittings Replacement	4-576
Front Loader Hydraulic Lines and Fittings Replacement	4-578
Front Loader/Forklift Hydraulic Lines and Fittings Replacement	4-580
Front Loader/Forklift Control Valve Hydraulic Lines and Fittings Replacement	4-582
Front Hydraulic Pump Lines and Fittings Replacement	4-584
Hand Tool Hydraulic Lines and Fittings Replacement	4-586
Front Hydraulic System Return Lines and Fittings Replacement	4-588
Rear Hydraulic Pump Lines and Fittings Replacement	4-590
Rear Hydraulic System Return Lines and Fittings Replacement	4-592
Backhoe/Crane Tilt Cylinder Hydraulic Lines and Fittings Replacement	4-594
Backhoe/Crane Latch Cylinder Hydraulic Lines and Fittings Replacement	4-596
Backhoe/Crane Hydraulic Lines and Fittings Replacement	4-598
Right Backhoe Stabilizer Cylinder Hydraulic Lines and Fittings Replacement	4-600
Left Backhoe Stabilizer Cylinder Hydraulic Lines and Fittings Replacement	4-602
Backhoe Stabilizer Control Valve Hydraulic Lines and Fittings Replacement	4-604
Backhoe Swing Cylinder Hydraulic Lines and Fittings Replacement	4-606
Backhoe Control Valve, Swing Section Hydraulic Lines and Fittings Replacement	4-608
Backhoe Boom Cylinder Hydraulic Lines and Fittings Replacement	4-610
Backhoe Control Valve, Boom Section Hydraulic Lines and Fittings Replacement	4-612
Backhoe Dipper Cylinder Hydraulic Lines and Fittings Replacement	4-614
Backhoe Bucket Cylinder Hydraulic Lines and Fittings Replacement	4-616
Backhoe Control Valve, Bucket Section Hydraulic Lines and Fittings Replacement	4-618
Forklift Tilt Cylinder Hydraulic Lines and Fittings Replacement	4-620
Forklift Hydraulic Lines and Fittings Replacement	4-622
Forklift Rotator Cylinder Hydraulic Lines and Fittings Replacement	4-624
Forklift Pulley Hydraulic Lines and Fittings Replacement	4-626
Forklift Lift Cylinder Hydraulic Lines and Fittings Replacement	4-628
Forklift Lift Cylinder Bleeding	4-630
Crane External End Extension Cylinder Hydraulic Lines and Fittings Replacement	4-632
Crane Turntable Motor Hydraulic Lines and Fittings Replacement	4-634
Crane Inner Boom Lift Cylinder Hydraulic Lines and Fittings Replacement	4-636
Crane Mast Locking Cylinder Hydraulic Lines and Fittings Replacement	4-638
Crane Supply Lines and Fittings Replacement	4-640
Crane Return Lines and Fittings Replacement	4-642
Crane Outer Boom Cylinder Hydraulic Lines and Fittings Replacement	4-644
Crane Horizontal Outrigger Cylinder Hydraulic Lines and Fittings Replacement	4-646
Crane Vertical Outrigger Cylinder Hydraulic Lines and Fittings Replacement	4-648
Hydraulic Suspension Lockout Lines and Fittings Replacement	4-650
Hydraulic Suspension Lockout Pump and Reservoir Lines and Fittings Replacement	4-652
Loader Boom Cylinder Replacement	4-654
Loader Bucket Rollback Cylinder Replacement	4-656
Backhoe Boom Cylinder Replacement	4-658
Backhoe Swing Cylinder Replacement	4-660
Backhoe Bucket Cylinder Replacement	4-668
Backhoe Dipper Cylinder Replacement	4-670
Backhoe Stabilizer Cylinder Replacement	4-673
Backhoe/Crane Tilt Cylinder Replacement	4-675
Backhoe/Crane Latch Cylinder Mounting Replacement	4-677
Backhoe Travel Lock Replacement and Repair	4-678
Backhoe Travel Lock Replacement and Repair	4-681
Backhoe/Crane Latch Cylinder Replacement	4-684

LIST OF TASKS (CONT)

HYDRAULIC SYSTEM MAINTENANCE (Section XVI)-CONT

	Page
Forklift Tilt Cylinder Replacement	4-686
Forklift Rotator Cylinder Replacement	4-688
Crane External End Extension Cylinder Replacement	4-690
Crane inner Boom Lift Cylinder Replacement	4-692
Crane Mast Locking Cylinder Replacement	4-694
Crane Outer Boom Cylinder Replacement	4-696
Crane Horizontal Outrigger Cylinder Replacement	4-698
Crane Vertical Outrigger Cylinder Replacement	4-700
Front Hydraulic Tank Replacement and Repair	4-702
Front Hydraulic Tank Filter Replacement	4-709
Rear Hydraulic Tank Replacement and Repair	4-712
Hydraulic Tank Sight Indicator Replacement	4-719
Rear Hydraulic Tank Filter Replacement	4-720
Hydraulic Oil Cooler Replacement.	4-722

GAGES (NON-ELECTRICAL) MAINTENANCE (Section XVII)

Speedometer Replacement	4-727
Speedometer Drive Shaft Replacement	4-730
Inclinometer Replacement and Adjustment	4-731
Counter Engine Revolution (Hourmeter) Replacement	4-733
STE/ICE-R Tachometer Drive and Cable Replacement	4-734

MACHINE TOOLS AND RELATED EQUIPMENT MAINTENANCE (Section XVIII)

Hammer Drill Hoses Replacement.	4-736
Impact Wrench Hoses Replacement	4-738
Pavement Breaker Hoses Replacement	4-740
Chain Saw Hoses Replacement.. . . .	4-742
Chain Saw Chain and Bar Replacement	4-744
Chain Saw Trigger, Guard, and Handle Bar Replacement	4-746

CRANES, SHOVELS, AND EARTHMOVING EQUIPMENT COMPONENTS MAINTENANCE
(Section XIX)

Backhoe Boom Replacement	4-752
Backhoe Assembly Replacement.. . . .	4-754
Backhoe Dipper Replacement and Repair	4-760
Backhoe Bucket Replacement	4-762
Backhoe Bucket (Ripper) Bearings Replacement	4-763
Backhoe Bucket Links Replacement	4-764
Backhoe Bucket/Ripper Tooth Replacement	4-766
Backhoe Boom Latch Release Lever Replacement	4-768
Backhoe Boom Latch Replacement	4-770
Backhoe Swing Tower Replacement	4-772
Backhoe Stabilizer Replacement.. . . .	4-774
Crane Replacement	4-776
Crane Hook Assembly Replacement	4-783
Crane Rear Outrigger Replacement	4-784
Crane Travel Lock Replacement and Adjustment	4-786
Crane Rotation Lock Replacement and Adjustment	4-790
Front Loader Replacement	4-794

LIST OF TASKS (CONT)

CRANES, SHOVELS, AND EARTHMOVING EQUIPMENT COMPONENTS MAINTENANCE (Section XIX)-CONT

	Page
Front Loader Main Frame Replacement	4-800
Front Loader Bucket Replacement	4-802
Front Loader Bucket Tooth Replacement	4-804
Front Loader Lift Arm Replacement	4-805

HOW TO USE THIS MANUAL

This manual has an edge index that will help you find specific information in a hurry. Simply spread the pages in the right edge of the manual until the printed blocks can be seen. Open the manual where the block on the edge of the page lines up with your selected topic printed in the front cover block.

OVERVIEW

This manual is organized by chapters, sections, and appendices. A summary of the organization of this manual, by major divisions, follows:

Front cover index gives you a quick reference to chapters, sections, and appendices that you will use often.

WARNINGS—All warnings you should observe while working on or around the SEE/HMMH are shown in this part of the manual. These are repeated in the parts of the manual where they apply.

Table of Contents—The contents of the chapters and appendices are listed here.

Chapter 1—This chapter contains general information about the SEE/HMMH. It also shows and describes major components and lists specific data that you will find helpful while performing maintenance tasks.

Chapter 2—This chapter describes services and inspections that must be performed at the unit level, such as services you must perform upon receipt of the vehicle, and preventive maintenance checks and services. Other sections contain painting and restenciling of markings and general repair and cleaning methods.

Chapter 3—This chapter outlines troubleshooting of the SEE/HMMH and their systems. It includes a troubleshooting index, by symptom and system, and procedures on how to use the STE/ICE-R components while troubleshooting.

Chapter 4—This chapter contains step-by-step instructions for doing the maintenance tasks. Each system of the SEE/HMMH has its own section within the chapter, and any special tools, equipment, or supplies you may need for a task are listed.

Appendix A—This appendix lists the technical manuals and other publications you may have to refer to while working on the SEE/HMMH.

Appendix B—This appendix contains the Maintenance Allocation Chart (MAC) for the SEE/HMMH.

Appendix C—This appendix lists the expendable supplies and materials you will need while performing maintenance on the SEE/HMMH.

Appendix D—This appendix lists and describes any manufactured items you will need for performing maintenance on the SEE/HMMH.

Appendix E—This appendix describes the proper method of tightening fasteners.

Index—The index is an alphabetical listing of the contents of this manual.

Back Cover—The inside back cover contains a metric conversion table.

USING THE MANUAL ON THE JOB

Find the task or component that needs repair by using the LIST OF TASKS (page iii) or the Index (page Index-1), then turn to the page listed for that task or component.

Read the INITIAL SETUP procedures, and gather the necessary items and personnel. Pay attention to the warnings. The INITIAL SETUP sheet is described on page xiv.

Although tasks are complete in detail, complete only the part of the task required. For example, if your task is to replace both air cleaner elements, you need not perform the remainder of the task to remove and replace the air cleaner canister.

① **FORKLIFT REPLACEMENT**

② This task covers: a. Removal b. Installation

INITIAL SETUP

③ **Applicable Configuration:**
HMMH

④ **Tools and Special Equipment:**
Shop Equipment, SC 4910-95-CL-A74
Tool Kit, SC 5180-90-CL-N26
Stand (2), P/N 419 580 70 18

⑤ **Materials/Parts:**
Washer, Lock (2)
Caps and Plugs Appendix C, Item 7
Rags Appendix C, Item 32

⑥ **Personnel Required:** (2)

⑦ **References:**
TM 5-2420-224-10

⑧ **Equipment Condition:**

Reference	Condition Description
Page 2-23	Hydraulic Pressure Relieved

⑨ **General Safety Instructions:**

WARNING

- HMMH should not be operated with forklift removed, except in a maintenance facility. When maintenance is required and forklift is removed, never operate HMMH at speeds greater than 5 mph. Tractor stability and handling characteristics are greatly affected with forklift removed. This could cause loss of control and injury to personnel or damage to vehicle.
- High pressure hydraulics [oil under 2450 psi (26,893 kPa)] operate this equipment. Never disconnect any hydraulic line or fitting without first dropping

1. TITLE—This is the name of the task.
2. TASK COVERS-This lists all the tasks included in the module.
3. APPLICABLE CONFIGURATION—If the task is applicable to only one of the vehicles. SEE or HMMH (as appropriate) will be listed here.
4. TOOLS AND SPECIAL EQUIPMENT—These are the tools and equipment you will need to do the task.
5. MATERIALS/PARTS—These are the supplies you will need to do the task. If parts or materials are required, they are listed here or referenced to Appendix C.
6. PERSONNEL REQUIRED-Personnel required to perform a task will be identified if the task requires more than one.
7. REFERENCES-These are the other technical publications you will need to do the task.
8. EQUIPMENT CONDITION—This is the condition(s) the vehicle must be in before you start the task. Other tasks that must be done first are listed by page number or by technical manual number if another manual is required.
9. GENERAL SAFETY INSTRUCTIONS—These are the safety precautions that must be observed while you are doing the task.
10. FOLLOW-ON MAINTENANCE—These are the tasks listed at the end of the procedure that must be completed to return the vehicle to an operational condition.

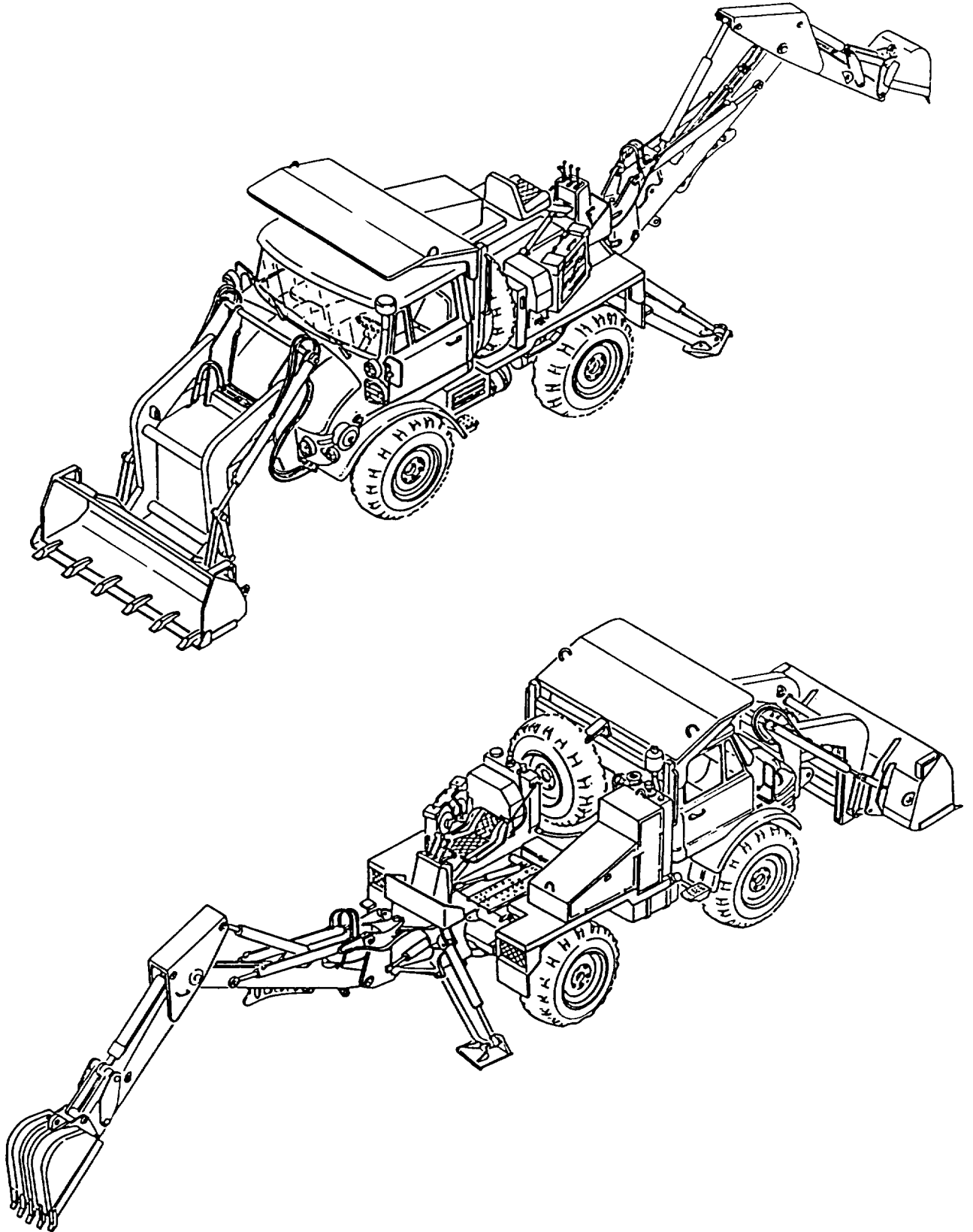

Small Emplacement Excavator (SEE)

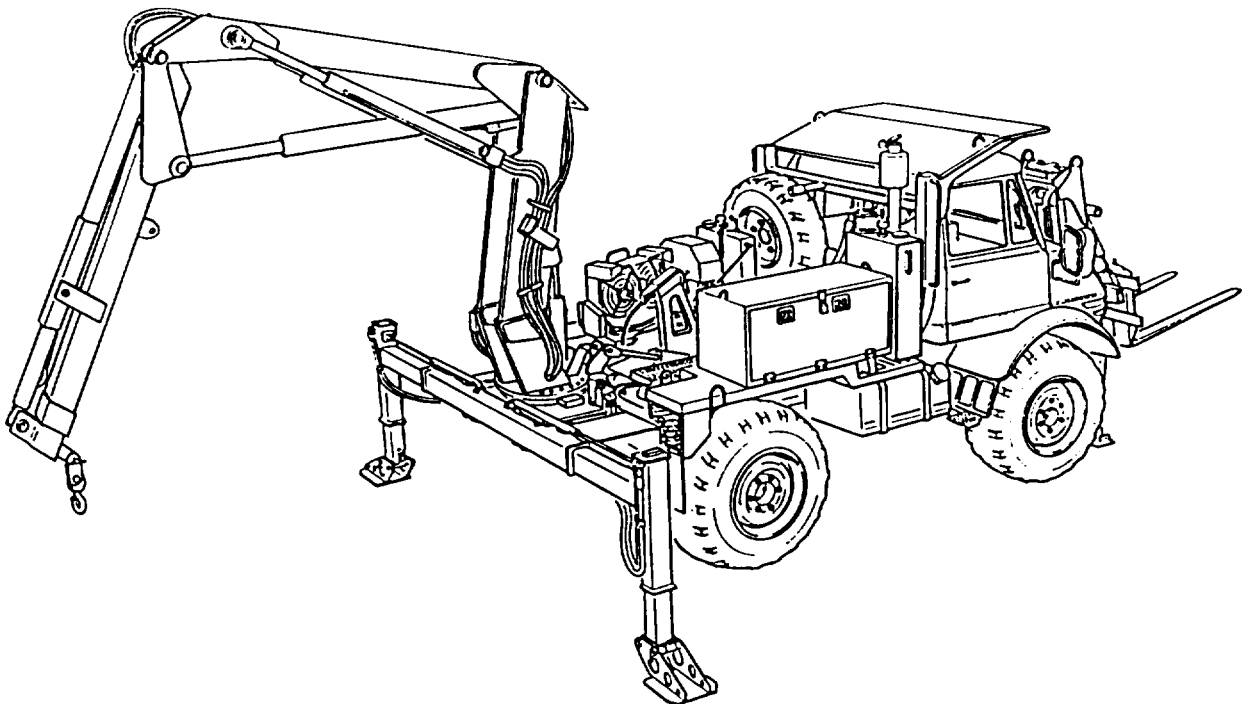
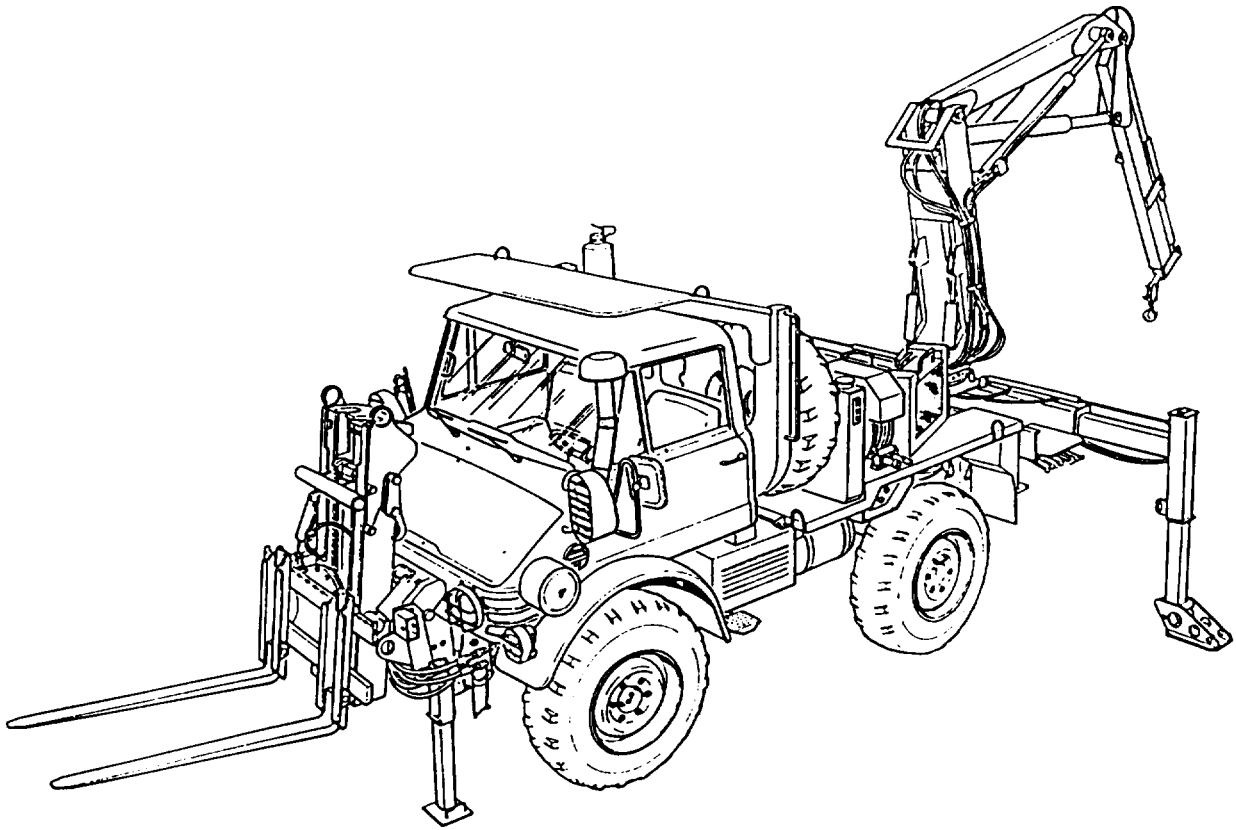

High Mobility Material Handler (HMMH)

CHAPTER 1 INTRODUCTION

SCOPE

A list of sections contained in this chapter is shown below.

	Page
Section I. General Information	1-1
Section II. Equipment Description and Data	1-3
Section III. Principles of Operation	1-8

Section I. GENERAL INFORMATION

OVERVIEW

Type of Manual: Unit Maintenance.

Model Number and Equipment Name:

Model No. FLU10144 Tractor, Wheeled, 4X4 DED Small Emplacement Excavator (SEE) with Attachments, NSN 2420-01-160-2754 (EIC:EDL).

Model No. FLU10344 Tractor, Wheeled, 4X4 DED High Mobility Material Handler (HMMH) with Attachments, NSN 2420-01-205-8636.

Purpose of Equipment:

The SEE is used for excavation, loading, lifting, and grading on various types of terrain. The vehicle is equipped with a front loader, backhoe, chain saw, pavement breaker, and hammer drill and is capable of rapid deployment for constructing protective positions.

The HMMH is used for material handling with forklift and crane attachments. The vehicle is equipped with an impact wrench to assist in maintenance of other equipment and is capable of rapid deployment.

MAINTENANCE FORMS, RECORDS, AND REPORTS

Department of the Army forms and procedures used for equipment maintenance will be those prescribed by DA Pam 738-750, The Army Maintenance Management System (TAMMS).

DESTRUCTION OF ARMY MATERIEL TO PREVENT ENEMY USE

When the tactical situation requires that Army materiel be abandoned, refer to TM 750-244-6, Procedures for Destruction of Tank-Automotive Equipment to Prevent Enemy Use, for procedures on destruction of the vehicle(s).

PREPARATION FOR STORAGE OR SHIPMENT

Instructions for storage and shipment, including administrative storage, are found in TM 740-90-1, MIL-V-62038D, and Chapter 2, Section VII.

REPORTING EQUIPMENT IMPROVEMENT RECOMMENDATIONS (EIRs)

If your vehicle needs improvement, let us know. Send us a Quality Deficiency Report. You, the user, are the only one who can tell us what you don't like about your equipment. Let us know why you don't like the design or performance. Put it on an SF Form 368 (QDR) and mail it to:

Commander
U.S. Army Tank-Automotive Command
Attn: AMSTA-QRT
Warren, MI 48397-5000

WARRANTY INFORMATION

The vehicles are warranted by Freightliner Corporation in accordance with TB 5-2420-224-15. Warranty starts on the date found in block 23, DA Form 2408-9 in the logbook. Report all defects in material or workmanship to your supervisor, who will take appropriate action through your unit maintenance shop.

METRIC SYSTEM

The equipment described herein contains metric components and requires metric common and special tools; therefore, metric units in addition to English units will be used throughout the manual. An English-to-metric conversion table is included as the last page of this manual inside the back cover.

Section II. EQUIPMENT DESCRIPTION AND DATA

OVERVIEW

This section contains information useful when performing unit level maintenance tasks on the SEE/HMMH. Refer to TM 5-2420-224-10 for additional equipment description and data.

EQUIPMENT CHARACTERISTICS, CAPABILITIES, AND FEATURES

Characteristics

- Low center of gravity for stability
- Convoy speed
- Small turning radius
- 17-in. (43.2-cm) ground clearance under axles and frame
- Rapid deployment
- Multiple attachment versatility

Capabilities and Features

- Broad range of angles of approach and departure
- Four-wheel drive and differential locks on both axles can be engaged and disengaged while moving
- High-mounted air intake and vertical exhaust
- Traverse up and down 60% slopes and 30% side slopes
- 30-in. (76.2-cm) fording depth
- Power assisted disc brakes on all four wheels
- Power steering
- All steel cab
- Roll-Over Protective Structure (ROPS)
- Falling Objects Protective Structure (FOPS)
- Utility mounting platforms
- Trailer towing equipment
- Front loader/forklift or backhoe/crane and machine (hydraulic) tools can be operated simultaneously

LOCATION AND DESCRIPTION OF MAJOR COMPONENTS

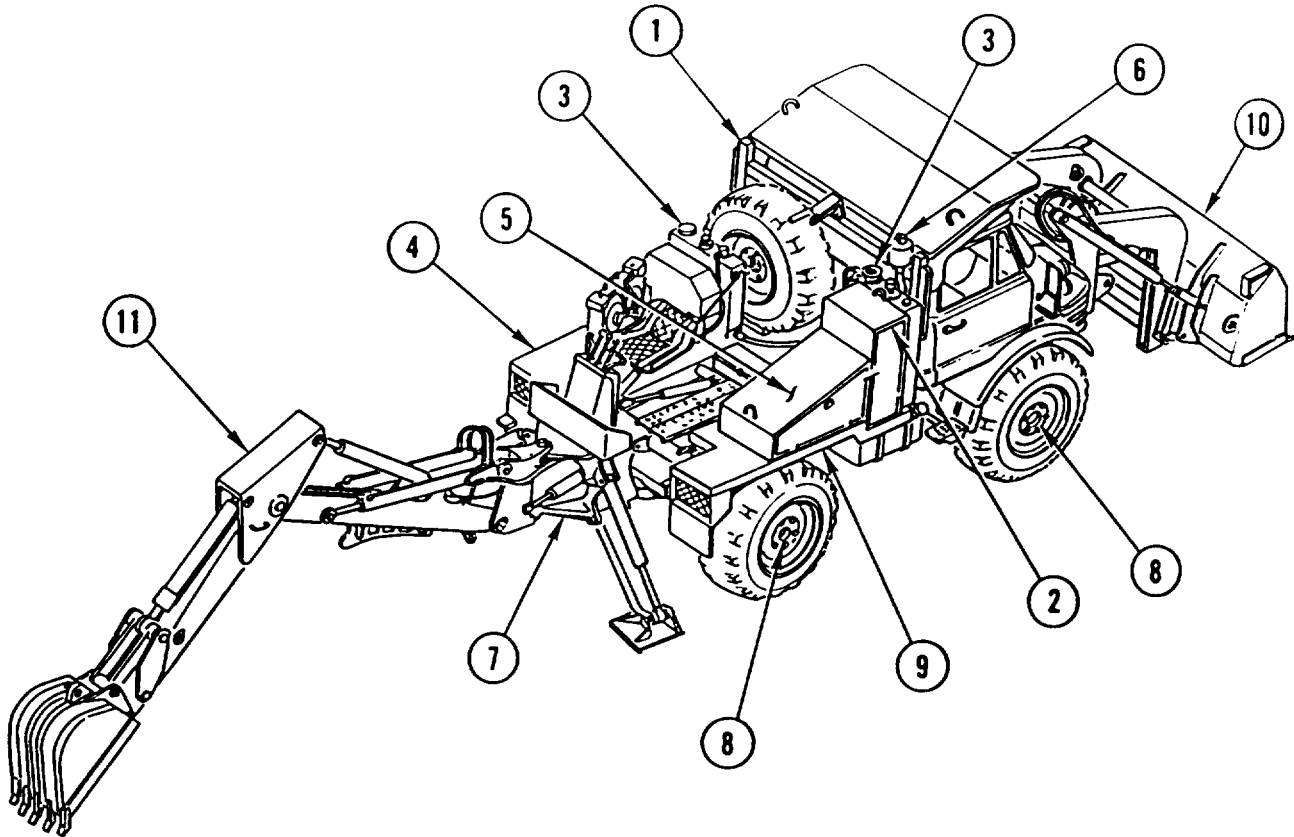

ROLL-OVER PROTECTIVE STRUCTURE (ROPS) (1). Protects cab if vehicle roll-over occurs.

STOWAGE (2). Hydraulic tools and equipment.

HYDRAULIC SYSTEM (3). Belt driven front system and Power Take-Off (PTO) driven rear system, rated to power front loader/forklift, backhoe/crane, and machine tools.

UTILITY PLATFORM (4). Solid base, access backhoe operations.

BASIC ISSUE ITEMS (BI) TOOLS (5). Stored behind cab in hydraulic accessory box.

VERTICAL EXHAUST (6). Mounted behind cab.

TRAILER TOWING EQUIPMENT (7). Tow pintle with air brake and electrical connections.

FOUR-WHEEL DRIVE (8). Four-wheel drive with differential lock, front and rear axles.

CHASSIS FRAME (9). Flexible, ladder-type, high-strength steel.

FRONT LOADER (SEE) (10). Used for excavating and filling excavations.

BACKHOE (SEE) (11). Digs excavations and trenches.

LOCATION AND DESCRIPTION OF MAJOR COMPONENTS (CONT)

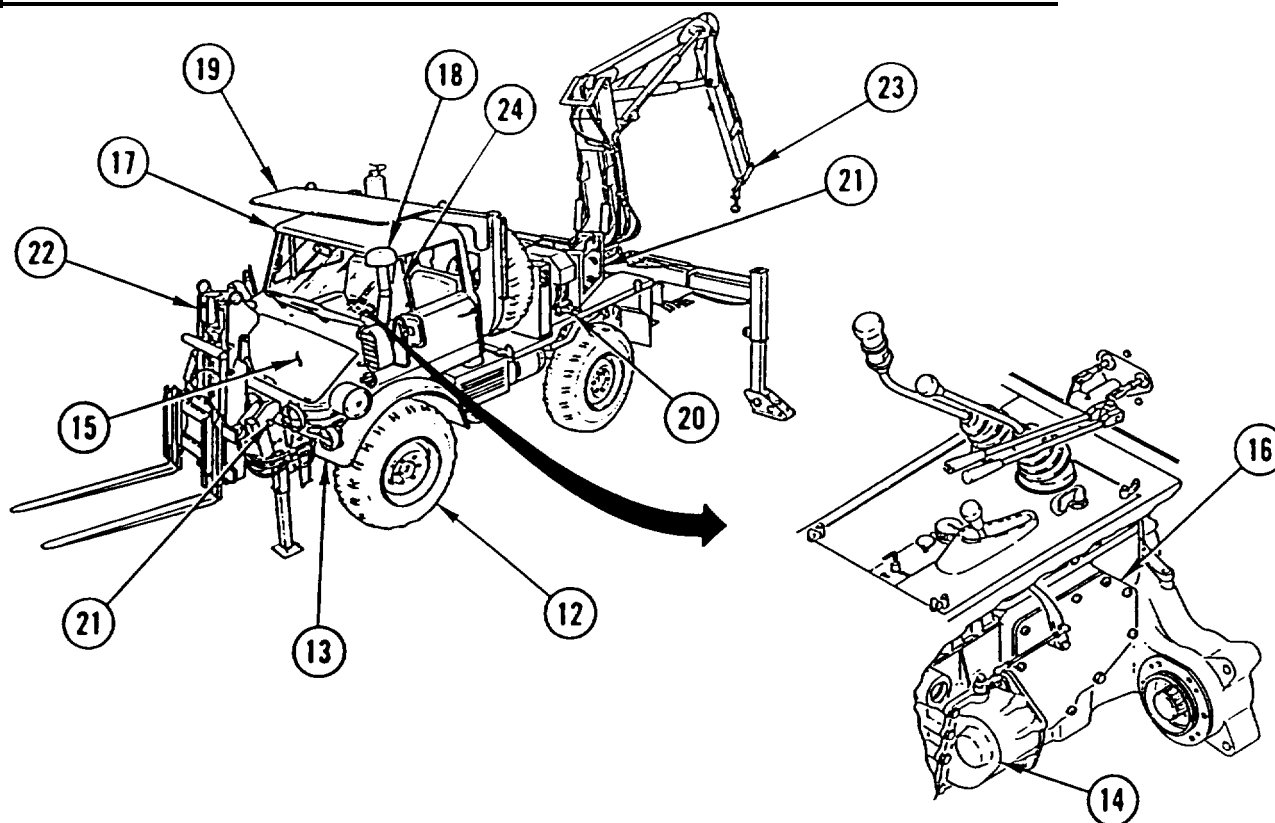

MULTIPLE PURPOSE TIRES (MPT) (12). Low-pressure high-traction radial ply with mounted spare.

SUSPENSION (13). Coil springs, shock absorbers, and front suspension lockout cylinders on the HMMH.

POWER TAKE-OFF (PTO) (14). Supplies power to the rear hydraulic pump.

ENGINE (15). Four-stroke, six-cylinder diesel.

TRANSMISSION (16). Fully synchronized 16 forward, 8 reverse, and pneumatic preselect shift mechanism.

CAB (17). Two-person, all steel construction.

HIGH MOUNTED AIR INTAKE (18). Mounted on left front corner of cab.

FALLING OBJECTS PROTECTIVE STRUCTURE (FOPS) (19). Protects cab from falling objects.

HYDRAULIC TOOL COUPLINGS (20). Quick-disconnect type.

FRONT LOADER/FORKLIFT and BACKHOE/CRANE ATTACHMENT POINTS (21). One-person operation, easy installation and removal of front loader/forklift and backhoe/crane.

FORKLIFT (HMMH) (22). Loads and unloads palletized material.

CRANE (HMMH) (23). Lifts material for maintenance and supply operations.

FIRE EXTINGUISHER (24). Mounted between seats.

EQUIPMENT DIFFERENCES

SEE Tractor	HMMH Tractor
Front Loader	Suspension lockout system
Backhoe	Forklift
Chain saw	Crane
Pavement breaker	Impact wrench
Hammer drill	

EQUIPMENT DATA

Engine
 Manufacturer Daimler-Benz
 Model 353.999
 Type 4-stroke diesel, 6 cylinder
 Horsepower 110(81kW)

Clutch
 Type Single dry plate

Engine Air Cleaner
 Manufacturer Donaldson
 Model FSGO9-0160
 Type Dry

Fuel System
 Fuel Pump
 Manufacturer Bosch
 Timing @ 700 rpm +50 Low idle
 Injection Order 1-5-3-6-2-4
 Fuel Tank
 Capacity 30 gallons(114 l)

Cooling System
 Capacity 6 gallons (23 l)

Electrical System
 Batteries
 Number 2
 Type Lead-acid
 Voltage 12vdc
 Connected Series
 Output 24 vdc
 Post to Ground Negative
 Alternator
 Manufacturer Bosch
 Rating 55 amps
 Drive Belt, by engine
 Starter
 Manufacturer Bosch

Transmission
 Type Fully synchronized
 Speeds 16 forward, 8 reverse
 Power Take-Off Engine driven

EQUIPMENT DATA (CONT)

Axles

Type Portal with reduction thrust tubes
 Drive 4-wheel

Suspension

Springs Coil
 Shock Absorbers Telescopic
 Front Lockout Hydraulic actuated (HMMH)

Brakes

Service
 Type 4-wheel, dual-circuit disc/caliper
 Power Actuated Hydraulic, air assist
 Warning System Low-air pressure (audible and visual)
 Parking
 Type Caliper, mechanical cable, rear wheels

Air Compressor

Type Engine driven
 Cylinders 1
 Bore 3.03 inches (77 mm)
 Stroke 1.18 inches (30 mm)
 Capacity @ 2600 rpm 4.77 cfm (135 lpm) @ 105 psi (724 kPa)

Wheels

Type Interchangeable rim and wheel
 Tires5 multipurpose
 Size 12.5 R20 12 PR radial
 Pressure Low
 Track Width64 inches (163 cm)

Steering

Type Recirculating ball with power assist
 Power Steering Pump.... . Belt, by engine

Hydraulic System

Front (SEE)
 Drive Engine
 Capacity 8 gpm @ 2450 psi (30 lpm @ 167 bar) @ 2000 engine rpm
 Use Front loader and machine tools

Rear (SEE)
 Drive PTO
 Capacity 26 gpm @ 2450 psi (98 lpm @ 167 bar) @ 2000 engine rpm
 Use Backhoe

Front (HMMH)

Drive Engine
 Capacity 8 gpm @ 2450 psi (30 lpm @ 167 bar) @ 2000 engine rpm
 Use Forklift and impact wrench

Rear (HMMH)

Drive PTO
 Capacity 14 gpm @ 2450 psi (54 lpm at 167 bar) @ 1100 engine rpm
 Use Crane

SAFETY, CARE, AND HANDLING

Warnings and cautions are listed in the front of the manual, at the beginning of each task, and at points where they apply in the maintenance procedures. In addition to these warnings, always keep in mind the following when working on the SEE/HMMH:

- The hydraulic system operates at pressures up to 2450 psi (167 bar).
- Be aware of where personnel are at all times when operating front loader/forklift and backhoe/crane.
- Do not allow personnel to walk under a raised front loader/forklift or backhoe/crane either during operation or maintenance.
- Always remove all jewelry and wristwatch, and make sure the vehicle MASTER disconnect switch is OFF before working on the electrical system.

Section III. PRINCIPLES OF OPERATION

OVERVIEW

This section contains information on the principles of operation of the SEE/HMMH. The general functional description of the vehicle's separate systems is contained in this section. Unit maintenance personnel should be familiar with the principles of operation of these systems before working on or troubleshooting these systems. A more thorough understanding of the electrical system can be obtained by referring to the electrical system schematic diagrams in the troubleshooting section in Chapter 3. The systems and components are:

Page

Power Train	
Engine	1-9
Transmission	1-9
Drive Shafts	1-9
Axles	1-10
Wheels and Tires	1-10
Fuel System	1-10
Exhaust System	1-10
Cooling System	1-11
Electrical System	
Alternator	1-11
StarterMotor	1-11
Batteries	1-11
Switches and Gages	1-12
Sending Units	1-12
Brake System	
Service Brakes	1-12
Parking Brake	1-12
SteeringSystem	1-13
Suspension	1-13
Earthmoving, Material Handling Components and Controls	
Front Loader (SEE)	1-14
Front Loader Controls (SEE)	1-14
Forklift (HMMH)	1-14
Forklift Controls (HMMH)	1-14
Backhoe (SEE)	1-15
Backhoe Controls (SEE)	1-15

OVERVIEW (CONT)

	Page
Crane (HMMH)	1-15
Crane Controls (HMMH)	1-15
Hydraulic System	
Front System	1-16
Rear System	1-16
Air System	1-16
Machine (Hydraulic) Tools	
Chain Saw (SEE)	1-17
Pavement Breaker (SEE)	1-17
Hammer Drill (SEE)	1-17
Impact Wrench (HMMH)	1-17

POWER TRAIN

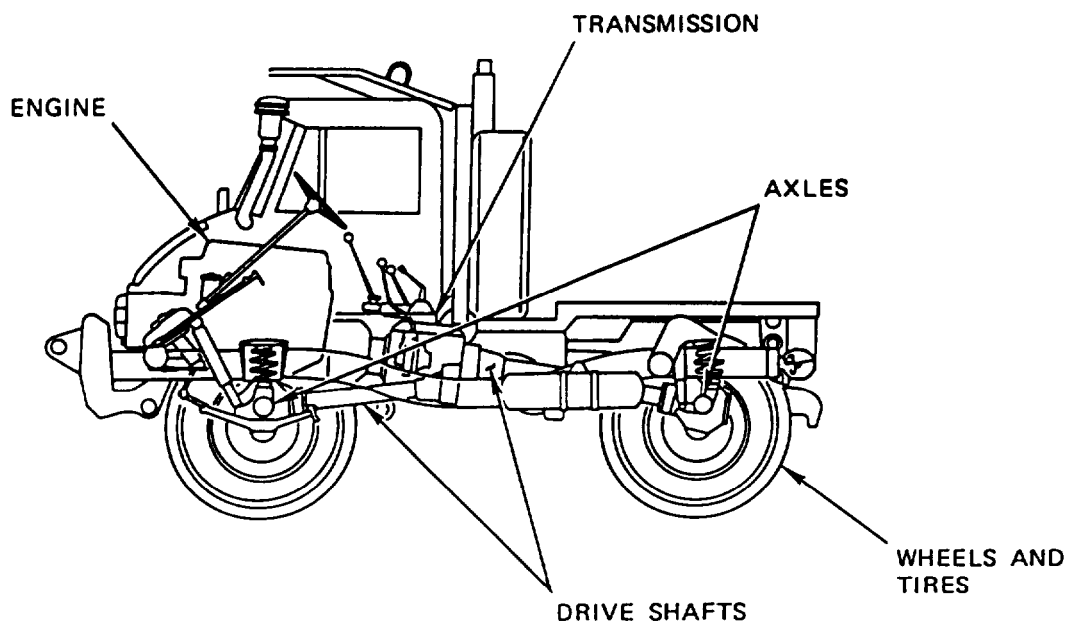

Engine. The engine is an in-line six cylinder, four stroke-cycle direct injection starting, valve-in-head type diesel that develops 110 horsepower (81 kW). An ether injection system is connected to the air intake manifold to aid in cold weather starting. The engine is water-jacket cooled. An engine oil sampling valve is supplied to easily obtain a sample of the engine oil. (Refer to LO 5-2420-224-12 for oil sampling procedures.)

Transmission. The transmission is manually operated with a single dry plate clutch. The main lever shifts all speeds no matter what gear range or intermediate speeds are preselected. Intermediate speed controls are main transmission reduction speeds and can be engaged and disengaged while driving in either forward or reverse. The group shift selector has three shifting functions: Range I, Range II, and Reverse. The Power Take-Off (PTO) lever engages and disengages the PTO when the clutch is fully depressed.

Drive Shafts. The purpose of the drive shafts is to transmit power to the axles from the transmission. The rear axle drive, four-wheel drive, and differential locks located on both axles can be engaged pneumatically while driving without interrupting the power flow.

POWER TRAIN (CONT)

Axles. There are two portal axles with hub reduction thrust tube mounted.

Wheels and Tires. Multipurpose tires are mounted on solid disc type wheels with the front and rear tires being equal in size. The rim size is 11.00-20, tire size is 12.5 R20 12 PR radial, and the track width is 64 in. (163 cm).

FUEL SYSTEM

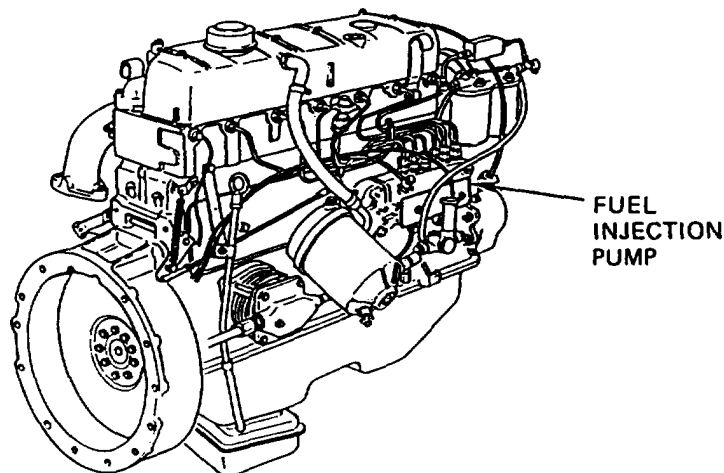

The fuel to power the engine is pumped out of the fuel tank by the fuel primer pump mounted on the fuel injection pump. The fuel pump is gear-driven directly from the engine camshaft. The fuel is filtered through a pre-sediment bowl and a primary and secondary fuel filter before it reaches the fuel injection pump, where it will be delivered to the fuel injectors. Fuel may be shut off near the tank with the shutoff valve.

EXHAUST SYSTEM

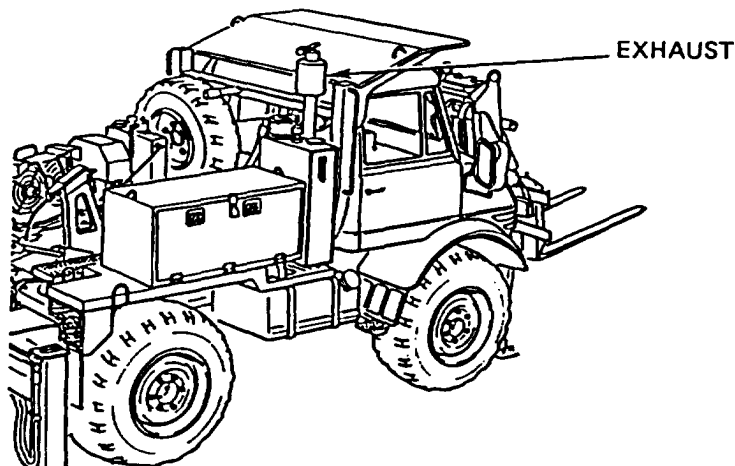

The exhaust system consists of an exhaust pipe from the manifold, a muffler, a vertical exhaust pipe, and a spark arrester.

COOLING SYSTEM

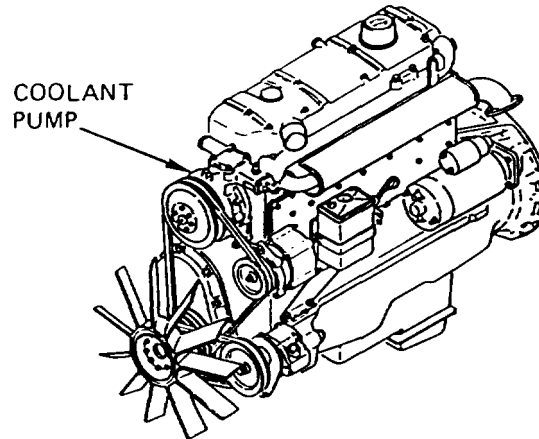

The coolant heated in the engine is circulated through the cooling system by an engine-driven coolant pump. The coolant is cooled in the coils of the radiator and any overflow is received in the expansion tank. The crankshaft-driven fan blows air through the radiator coils to aid cooling. The thermostat automatically regulates engine temperature by regulating the flow of heated coolant to the radiator.

ELECTRICAL SYSTEM

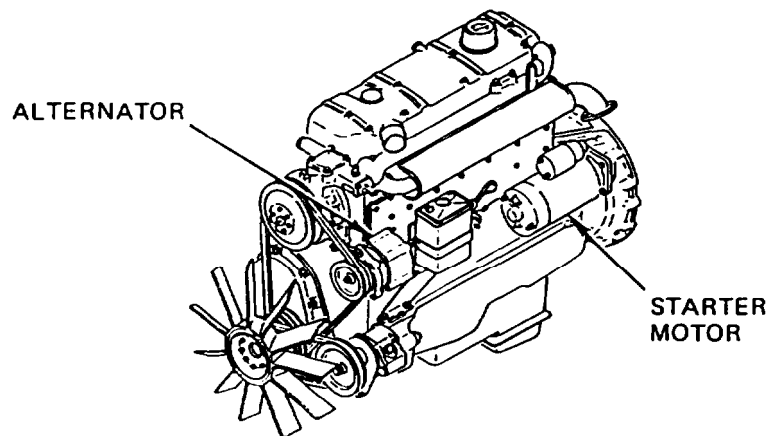

Alternator. The alternator is belt-driven at a speed sufficient to provide the electrical energy for the normal demands of the electrical system. Some of this energy is used to keep the batteries charged.

Starter Motor. The starter motor is located on the left rear side of the engine. It is activated by the start switch when the MASTER disconnect switch and power switch are on and the clutch is fully depressed.

Batteries. The two lead-acid batteries are mounted in a battery box located on the left side beneath the rear of the cab near the air reservoir tanks. The batteries provide electrical power to start the engine and supply power to the auxiliary circuit when the engine is stopped. A NATO-type slave receptacle is located next to the battery box to provide capability for a jump start from an auxiliary source if the batteries are too low to start the engine.

ELECTRICAL SYSTEM (CONT)

Switches and Gages. Refer to TM 5-2420-224-10 for the locations and detailed descriptions of the switches and gages.

Sending Units. The intermediate speed indicator is located on the right side of the transmission; the parking brake indicator is located on the cable lever at the center of the rear axle; the low air warning indicator is located on the air line to the trailer air brake valve; the Power Take-Off (PTO) indicator is located on the left side of the transmission housing at the PTO housing; the fuel level sending indicator is located on the right side top of the fuel tank; the neutral start switch indicator is located under the clutch pedal on the left side of the cab.

BRAKE SYSTEM

The vehicle is equipped with air-assisted hydraulic brakes. The dual circuit brake system utilizes four-wheel disc brakes with two calipers on each front wheel, one on each rear wheel, and a cable-operated parking brake at the rear.

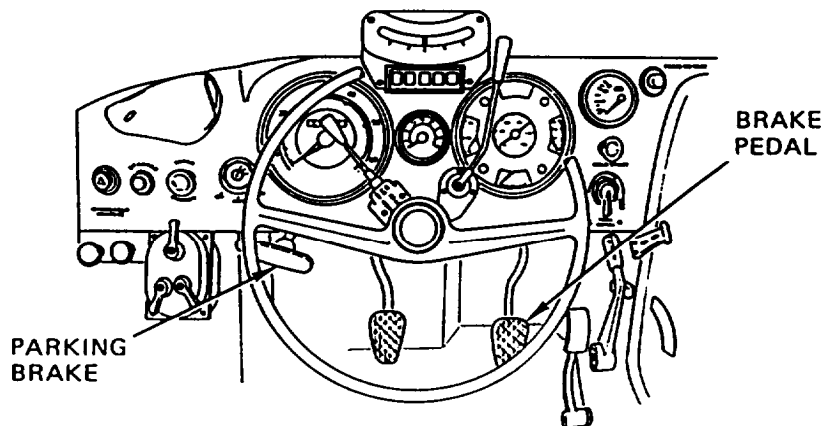

Service Brakes. The service brakes consist of the brake booster, master cylinder, brake pedal, brake pads and discs, service brake warning light, and air pressure warning alarm.

Parking Brake. A cable-actuated cam acts on the caliper brake on the rear wheel when the lever is pulled. There is also a parking brake warning light.

STEERING SYSTEM

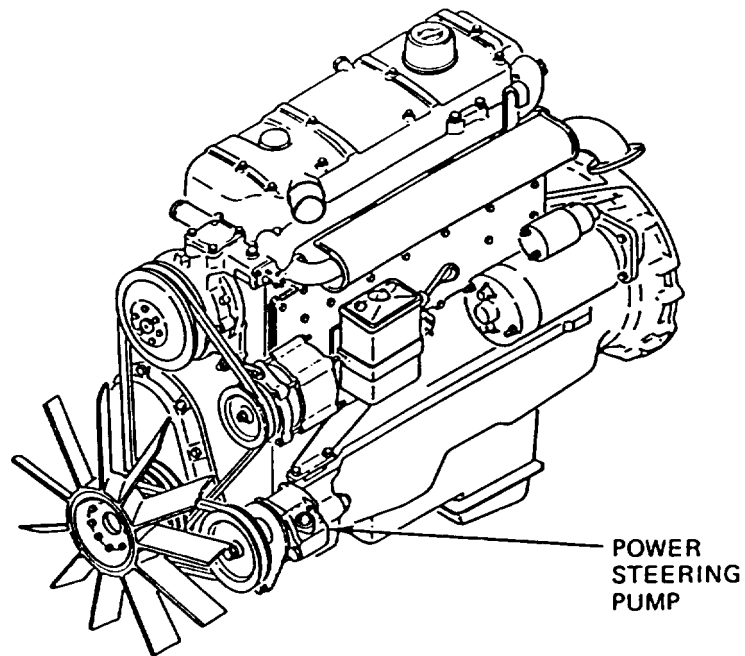

Steering is hydraulically powered and consists of a V-belt driven power steering pump, tie rods, drag link, pitman arm, and hydraulic reservoir and filter.

SUSPENSION

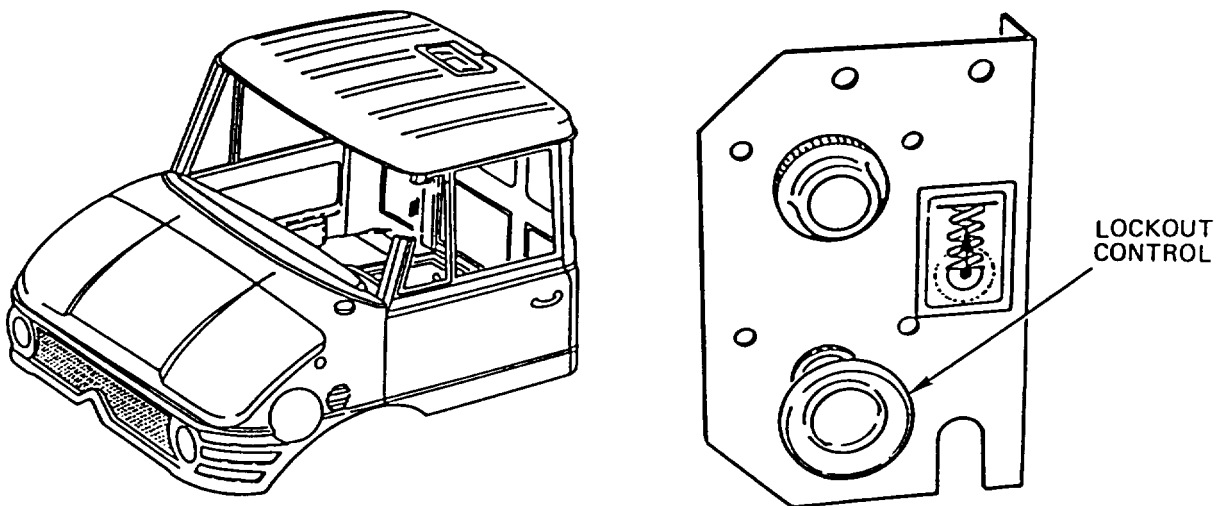

The suspension is mechanical and consists of coil springs, telescopic shock absorbers, and stabilizers. The HMMH uses a front suspension lockout system for use with forklift and crane operations.

EARTHMOVING, MATERIAL HANDLING COMPONENTS AND CONTROLS

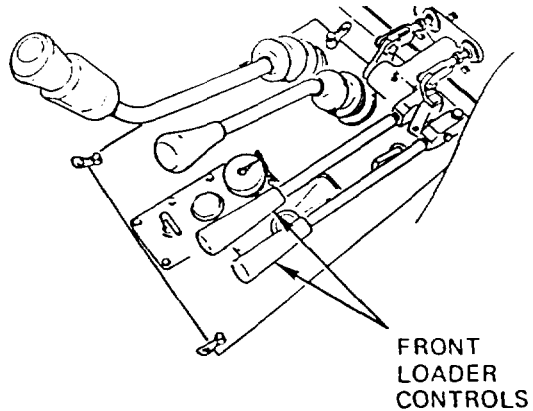
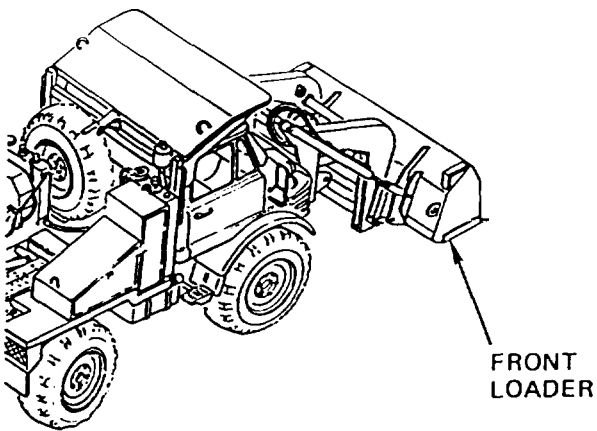

Front Loader (SEE). The front loader is used to scoop earth to construct fighting positions and artillery and missile emplacements, to grade surfaces, and to backfill excavations made with the backhoe.

Front Loader Controls (SEE). The front loader is equipped with two control levers located between the seats in the cab. Pull up on the left lever to raise the loader bucket, push down on the lever to lower the bucket, and push down past detent to activate the float feature. Pull up on the right lever to curl the loader bucket back, push down on the lever to curl the bucket down.

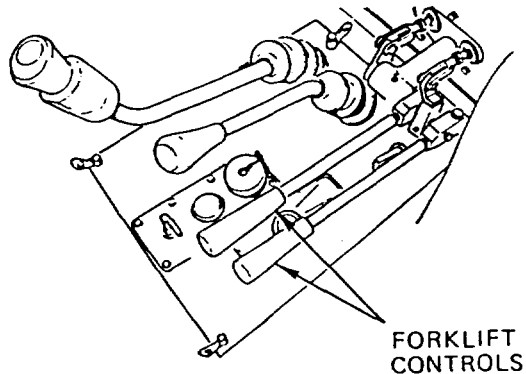
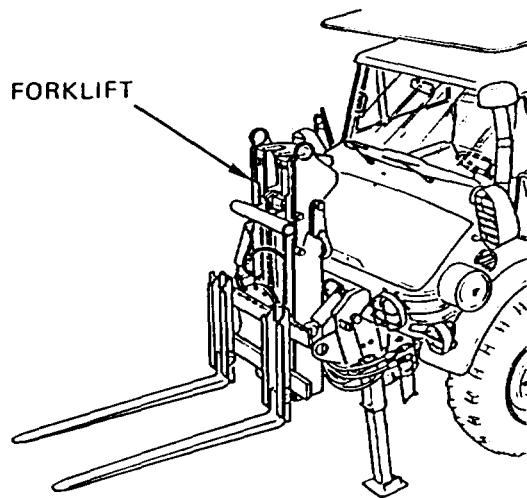

Forklift (HMMH). The forklift loads and unloads palletized cargo with the aid of the front suspension lockout system.

Forklift Controls (HMMH). The forklift is equipped with two control levers located between the seats in the cab. Pull up on the left lever to raise the mast, push down on the lever to lower the mast. Pull up on the right lever to tilt the mast back, push down on the lever to tilt the mast forward. Press the button on the right lever and pull up to rotate the carriage clockwise, press the button and push down to rotate the carriage counterclockwise.

EARTHMOVING, MATERIAL HANDLING COMPONENTS AND CONTROLS (CONT)

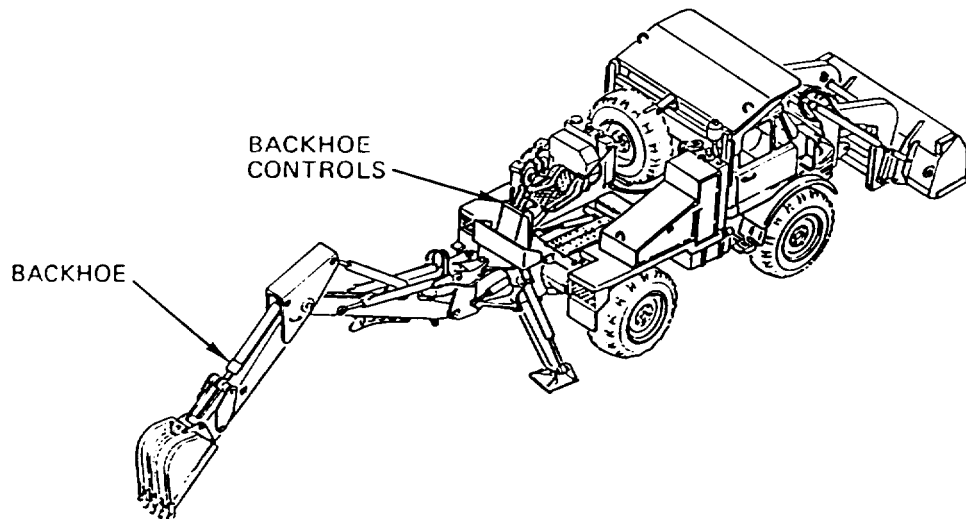

Backhoe (SEE). The backhoe is used to excavate trenches for fighting positions, communications, explosives, and power lines.

Backhoe Controls (SEE). The backhoe controls are located on the backhoe and operate the control cylinders. The backhoe controls consist of the stabilizer control levers, bucket control lever, dipper control lever, boom control lever, transport lock latch, and swing control pedals.

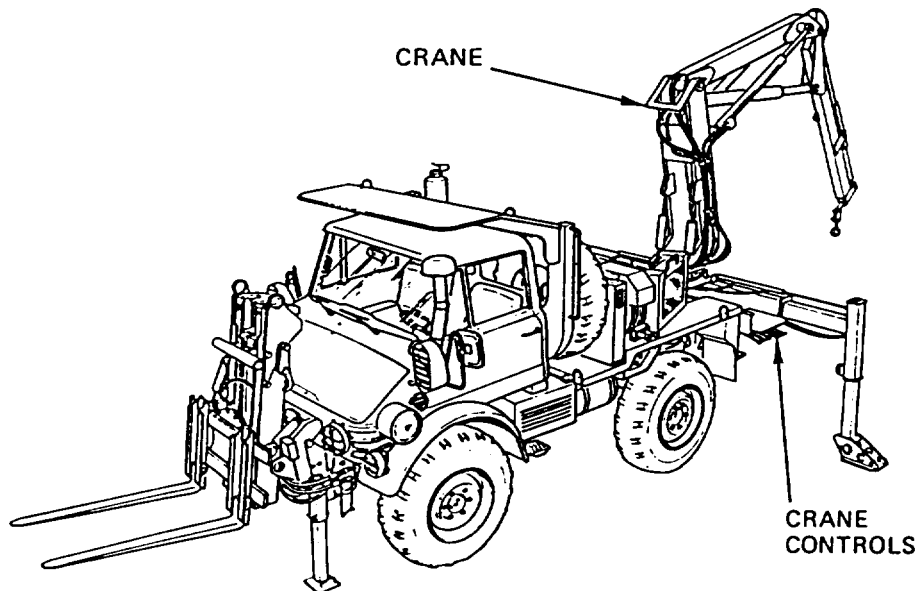

Crane (HMMH). The crane loads and unloads cargo and provides maintenance support in forward combat areas with the aid of the front suspension lockout system.

Crane Controls (HMMH). The crane controls are located on both sides of the vehicle when the crane is deployed. The crane controls consist of the mast folding lever, left outrigger vertical lever, right outrigger vertical lever, outrigger horizontal lever, boom extension lever, outer boom lever, inner boom lever, boom rotation lever, and latch levers.

HYDRAULIC SYSTEM

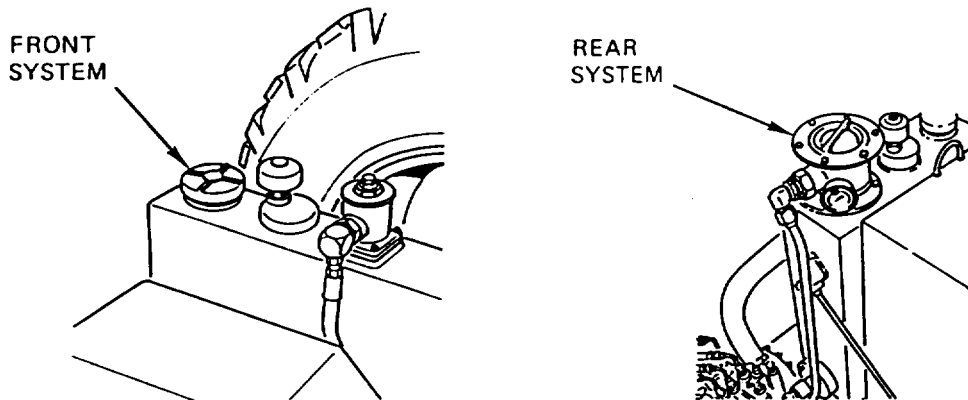

Front System. The front hydraulic system pump is belt-driven and supplies hydraulic fluid to the front loader/forklift and machine tools through an 11-gal (41.6-l) hydraulic tank located to the left rear of the cab.

Rear System. The rear hydraulic system pump is PTO-driven and supplies hydraulic fluid to the backhoe/crane through a 21-gal (79.4-l) hydraulic tank located to the right rear of the cab.

AIR SYSTEM

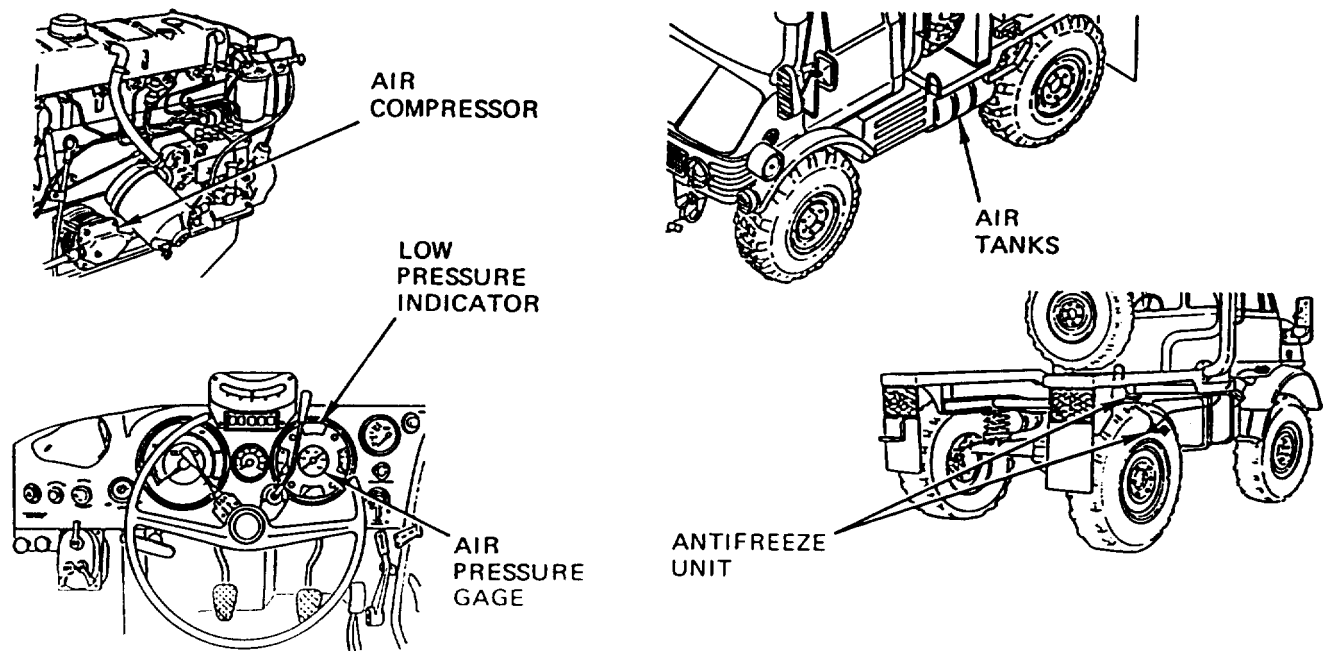

The air system consists of an air compressor, two air tanks, air pressure gage, low pressure indicator, low pressure buzzer, air pressure regulator, and compressed air antifreeze unit.

MACHINE (HYDRAULIC) TOOLS

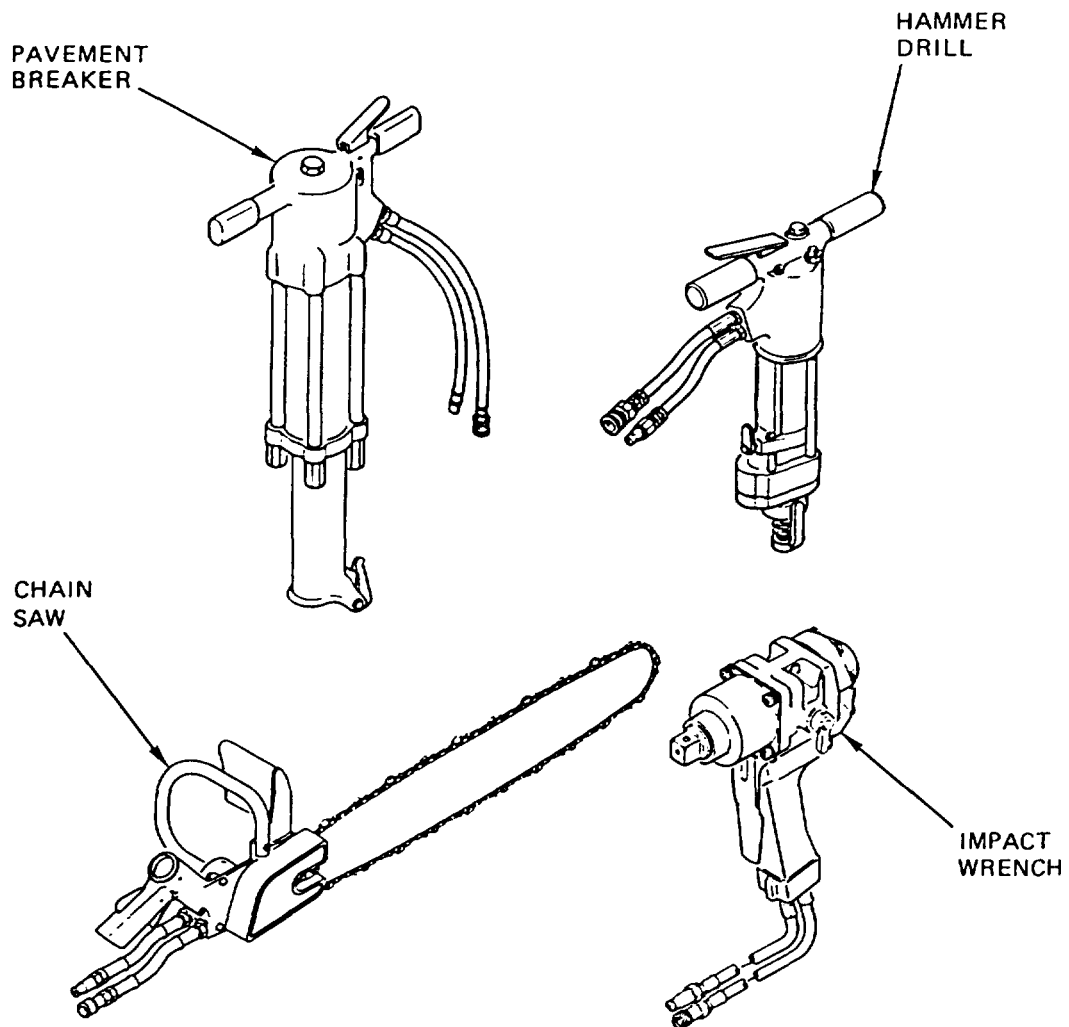

Chain Saw (SEE). The chain saw is used for debranching, pruning, and removal of trees and wood products. The 15-in. bar allows cutting of wood up to 30 in. in diameter. Squeezing the trigger controls the speed of the chain saw.

Pavement Breaker (SEE). The pavement breaker is used for breaking and chipping concrete, rock, pavement, and hard ground. The pavement breaker uses moil points, spade, and chisel attachments for breaking and chipping. Squeezing the trigger activates the pavement breaker.

Hammer Drill (SEE). The hammer drill is used for drilling holes in rock, concrete, or asphalt 3/4, 1, or 2 in. (12.7, 25.4, or 50.8 mm) in diameter. A switch controls the direction the tool operates. Squeezing the trigger activates and controls the speed of the hammer drill.

Impact Wrench (HMMH). The impact wrench is used for removing and installing hardware from containers and other equipment. A lever controls the direction and the trigger controls the speed of the impact wrench.

CHAPTER 2 SERVICES AND SCHEDULED VEHICLE MAINTENANCE

SCOPE

This chapter contains information you will need to prepare the SEE/HMMH for daily use and to perform preventive and scheduled maintenance. The following sections are included in this chapter.

		Page
Section I	Repair Parts, Special Tools; Test, Measurement, and Diagnostic Equipment (TMDE); and Support Equipment	2-1
Section II.	Service Upon Receipt	2-2
Section III.	Preventive Maintenance Checks and Services	2-2
Section IV.	Painting and Restenciling Markings	2-14
Section V.	General Repair and Cleaning Methods	2-15
Section VI.	General Hydraulic System Repair Methods	2-32
Section VII.	Preparation for Storage or Shipment	2-36

Section I. REPAIR PARTS, SPECIAL TOOLS; TEST, MEASUREMENT, AND DIAGNOSTIC EQUIPMENT (TMDE); AND SUPPORT EQUIPMENT

OVERVIEW

This section includes information on tools and equipment you need to support the SEE and HMMH tractors.

COMMON TOOLS AND EQUIPMENT

For authorized common tools and equipment, refer to the Modified Table of Organization and Equipment (MTOE) applicable to your unit. Tool kits required for each task in this manual are listed in the Maintenance Allocation Chart (MAC) in Appendix B and on the INITIAL SETUP page of each task.

SPECIAL TOOLS, TMDE, AND SUPPORT EQUIPMENT

Special tools and support equipment required to maintain the SEE/HMMH are listed in the Maintenance Allocation Chart (MAC) Appendix B and on the INITIAL SETUP page of each task. Special tools are also listed in the Repair Parts and Special Tools List (TM5-2420-224-24P). Tools that are to be fabricated are described and listed in Appendix D of this manual.

REPAIR PARTS

Repair parts are listed and illustrated in the Repair Parts and Special Tools List (TM5-2420-224-24P) covering the unit maintenance of this equipment.

Section II. SERVICE UPON RECEIPT

OVERVIEW

This section contains information on what to do when the vehicle is received.

CHECKING EQUIPMENT

1. Inspect the equipment for damage incurred during shipment. If the equipment has been damaged, report the damage on DD Form 6, Packaging Improvement Report.
2. Check the equipment against the packing slip to see if the shipment is complete. Report all discrepancies with the instructions of DA PAM 738-750, The Army Maintenance Management System (TAMMS).
3. Check to see whether the equipment has been modified.

INITIAL SERVICES

1. Follow all precautions and instructions on tag DA Form 1397, Processing Record for Shipment, Storage, and Issue of Vehicle and Spare Engines.
2. Remove all packing and shipping materials, such as tape, tiedowns, protective covers, and shipping seals.
3. Remove all BII and COEI equipment and store in accordance with TM 5-2420-224-10.
4. If batteries have not been serviced, refer to TM 9-6140-200-14.
5. Service the vehicle in accordance with TM 5-2420-224-10 and LO 5-2420-224-12.
6. Refer to TM 5-2420-224-10 and perform functional checks of all major vehicle systems.

Section III. PREVENTIVE MAINTENANCE CHECKS AND SERVICES

OVERVIEW

This section details the Preventive Maintenance Checks and Services (PMCS) required for the SEE/HMMH. PMCS is a scheduled, step-by-step inspection and service of the vehicle and vehicle components. Its purpose is to keep the vehicle in good condition and to identify and correct problems before costly and time-consuming repairs are needed.

MAINTENANCE FORMS AND RECORDS

Use DA Form 2404, Equipment Inspection and Maintenance Worksheet, to record periodic maintenance services performed and faults corrected. The item number on the DA Form 2404 must be the same as the item number of the PMCS. For information on maintenance forms and records, see DA Pam 738-750.

OPERATOR PARTICIPATION

The operator will perform the operator PMCS (TM 5-2420-224-10) and will also help unit maintenance do the unit PMCS, and perform lubrication in accordance with LO 5-2420-224-12.

INTERVALS

Unit PMCS should be performed at the intervals shown below:

- Do your (Q) PMCS quarterly (every 3 months).
- Do your (S) PMCS semiannually (every 6 months).
- Do your (A) PMCS annually (once every year).

PROCEDURES

Refer to the following illustrations and descriptions for information on how to inspect common items on the vehicle.

NUTS, BOLTS, AND SCREWS: Check for loose parts by looking for cracked or chipped paint around screw and bolt heads. Check for missing or broken cotter pins or lockwire.

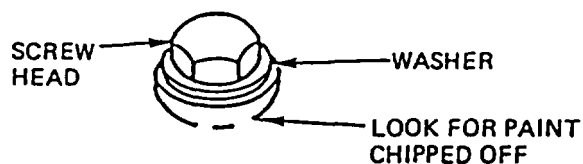

WELDS: Check for damaged welds by cracks in paint or metal, and chipped paint in seams.

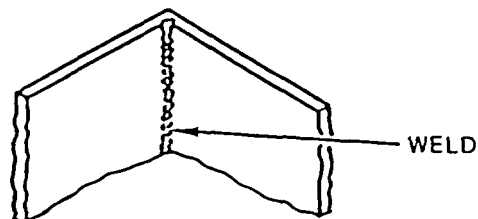

HOSES, TUBES, AND FITTINGS: Check all hoses, tubes, and fittings for damage, loose clamps, improper routing, leaks, looseness, and chafing. Do not overtighten hoses, tubes, or fittings.

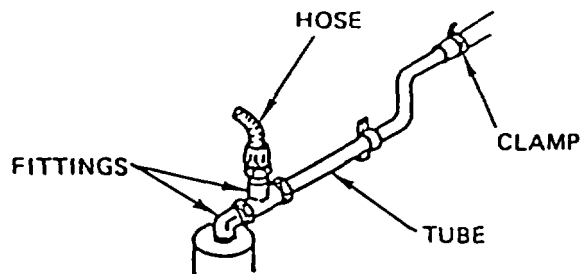

ELECTRICAL LEADS AND HARNESSSES: Check for loose or corroded leads and connectors, proper routing of harnesses, loose clamps, and chafing.

LEAKAGE DEFINITIONS

- Class I Leakage of fluid (as indicated by wetness or discoloration) not great enough to form drops.
- Class II Leakage of fluid great enough to form drops, but not enough to cause drops to drip from the item being checked/inspected.
- Class III Leakage of fluid great enough to form drops that fall from the item being checked/inspected.

Table 2-1. Preventive Maintenance Checks and Services

NOTE: Within designated interval, these checks are to be performed in the order listed.

INTERVAL DEFINITIONS

Q-Quarterly

S-Semiannually

A-Annually

Item No.	Interval			Item to be Inspected: Procedure: Check for and have repaired, filled, or adjusted as needed.
	Q	S	A	
1				<p style="text-align: center;">NOTE</p> <p>Perform all operator checks listed in Operator PMCS, as appropriate, as part of Road Test (TM 5-2420-224-10).</p> <p>ROAD TEST</p> <p style="text-align: center;">NOTE</p> <p>The following will be performed during Road Test. These inspections must be performed before any other unit level PMCS regardless of interval.</p> <p>During Road Test, vehicle will be driven at least 5 miles to give enough time to detect any malfunctions.</p> <p>STARTER</p> <ul style="list-style-type: none"> • While starting vehicle, listen for unusual noises and difficult cranking of starter.
				<p>ENGINE AND ENGINE COMPARTMENT</p> <ul style="list-style-type: none"> • Listen for unusual noises, hesitation, and varying idle speed; observe response to accelerator feed.

Table 2-1. Preventive Maintenance Checks and Services (Cont)

NOTE: Within designated interval, these checks are to be performed in the order listed.

INTERVAL DEFINITIONS

Q-Quarterly

S-Semiannually

A-Annually

Item No.	Interval			Item to be Inspected: Procedure: Check for and have repaired, filled, or adjusted as needed.
	Q	S	A	
3		●		AXLE Check operation of differential lock/four-wheel drive.
4	●			BRAKES a. Test braking response to brake pedal. Vehicle should slow down immediately. b. At speed of approximately 20 mph, apply brake pedal with steady force. Vehicle should stop smoothly without noticeable side-pull or chatter. c. With vehicle on downgrade and transmission in neutral, engage parking brake. Vehicle should not move.
5		●		STEERING Check vehicle response to steering wheel action. Vehicle should respond instantly. With vehicle on straight level ground, lightly hold steering wheel to check for pull or wander. With vehicle in motion, free play should be no more than approximately 1-1/2 in. (39 mm) in either direction.
6		●		ENGINE a. Check engine operation at all speeds. Ensure engine does not exceed governed speed (2850 ±50 rpm). b. Observe engine instruments to detect malfunctions.
7		●		SUSPENSION Observe how vehicle responds to road shocks. Shifts, knocks, or constant bouncing indicate possible malfunction.

Table 2-1. Preventive Maintenance Checks and Services (Cont)

NOTE: Within designated interval, these checks are to be performed in the order listed.

INTERVAL DEFINITIONS

Q-Quarterly

S-Semiannually

A-Annually

Item No.	Interval			Item to be Inspected: Procedure: Check for and have repaired, filled, or adjusted as needed.
	Q	S	A	
8				<p>AFTER ROAD TEST</p> <p>BRAKES, ROTORS, AND HUBS</p> <p style="text-align: center;"><u>WARNING</u></p> <p>Brake rotor can get very hot during vehicle operation and could cause burns. Place hand near brake rotor to check for excessive heat, but do not touch.</p> <ul style="list-style-type: none"> • a. Carefully check and compare each brake rotor for overheating, which can indicate dragging brake. Cool brake rotors could mean improper adjustment; defective, or inoperative brakes. <div style="text-align: center;">  </div> <ul style="list-style-type: none"> • b. Check brake pads. Minimum thickness should be 0.078 in. (2 mm).
9				<p>WHEELS AND TIRES</p> <p style="text-align: center;"><u>CAUTION</u></p> <p>Do not use bias ply tires on vehicle. To do so could result in damage to equipment.</p> <ul style="list-style-type: none"> • a. Inspect tires for unusual wear, penetrating objects, and improper matching. If required, match tires according to tread design and degree of wear (TM 9-2610-200-24). Inflate or deflate to correct pressure (TM 5-2420-224-10).

Table 2-1. Preventive Maintenance Checks and Services (Cont)

NOTE: Within designated interval, these checks are to be performed in the order listed

INTERVAL DEFINITIONS

Quarterly

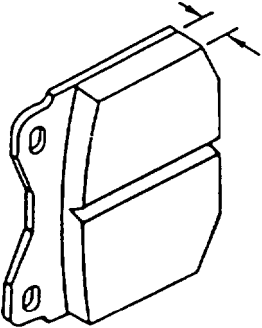
S-Semiannually

A-Annually

Item No.	Interval			Item to be Inspected: Procedure: Check for and have repaired, filled, or adjusted as needed.
	Q	S	A	
				WHEELS AND TIRES (CONT)
10		•		b. Check lug nuts for proper torque of 260 lb-ft (350 N.m).
				AIR BRAKE SYSTEM
11		•		Check brake system components for leaks and damage. Check all brake hoses for wear, pinching, or interference. If any of these conditions are found, replace or reposition hose. Replacement is mandatory for any hose worn or chafed before vehicle use. Replacement is mandatory for any hose that is leaking or has bulges.
				TRANSMISSION
12		•		Check transmission for leaks, loose bolts, and obvious damage.
				FRONT AXLE
13		•		Check for loose screws and missing or damaged mounting hardware.
				REAR AXLES
14		•		Check for loose screws and missing or damaged mounting hardware.
				SUSPENSION
15		•		a. Check coil springs for cracks or breaks.
		•		b. Check torque of coil spring mounting bolts. Torque should be 103 lb-ft (140 N.m).
				FRAME AND CROSSMEMBERS
		•		a. Inspect frame and side rails for cracks, breaks, bends, wear, deterioration, and loose bolts.

Table 2-1. Preventive Maintenance Checks and Services (Cont)

NOTE: Within designated interval, these checks are to be performed in the order listed.

INTERVAL DEFINITIONS

Q-Quarterly

S-Semiannually

A-Annually

Item No.	Interval			Item to be Inspected: Procedure: Check for and have repaired, filled, or adjusted as needed.
	Q	S	A	
16		•		<p>FRAME AND CROSSMEMBERS (CONT)</p> <p>b. Inspect crossmembers for weld breaks.</p>
		•		<p>STEERING</p> <p>a. Check steering gear for leaks and loose mounting bolts and components. Notify direct support maintenance for any repairs.</p>  <p>b. Check tie rod and drag link for movement by attempting to move by hand. Visually check ball joint ends for worn or damaged dust seals. If movement or damage is present, refer to direct support maintenance.</p>

Table 2-1. Preventive Maintenance Checks and Services (Cont)

NOTE: Within designated interval, these checks are to be performed in the order listed.

INTERVAL DEFINITIONS

Q-Quarterly

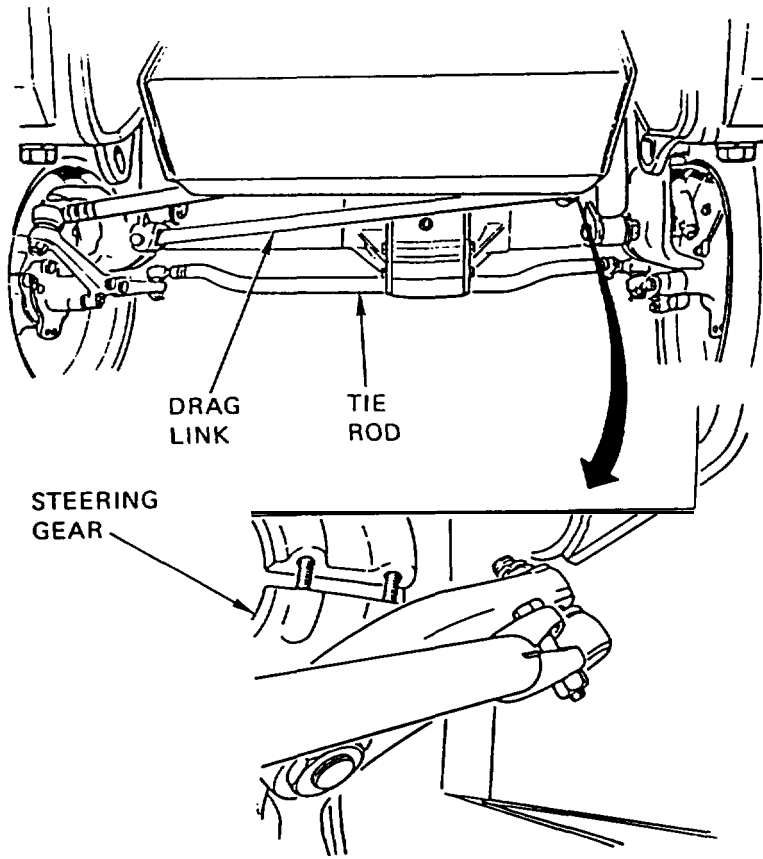
S-Semiannually

A-Annually

Item No.	Interval			Item to be Inspected: Procedure: Check for and have repaired, filled, or adjusted as needed.
	Q	S	A	
17		•		<p>STEERING (CONT)</p> <ul style="list-style-type: none"> c. Check all hydraulic steering lines, hoses, and tubes for loose fittings, rubbing, chafing, cracks, bends, breaks, and leaks. Tighten if loose and replace or repair hoses or lines that are damaged. d. Inspect power steering reservoir for leaks and loose hoses. e. Inspect power steering pump for leaks, cracks, or damage. <p>DRIVEBELTS</p> 
		•		<p>Check for proper tension/deflection of drivebelts. Fan belts should be 1/2-3/4 in. (13-19 mm). Alternator belt should be 1/4-3/8 in. (7-10 mm).</p>
18		•		<p>EXHAUST SYSTEM</p> <p style="text-align: center;"><u>WARNING</u></p> <p style="text-align: center;">BURN HAZARD</p> <p>Allow engine to cool before performing maintenance on the muffler, exhaust pipe, or exhaust manifold. If necessary, use insulated pads and gloves.</p> <ul style="list-style-type: none"> a. Check exhaust manifold, exhaust pipes, muffler, and tailpipe for leaks. Check for damaged pipes, loose clamps, and blown gaskets. b. Check raincap to make sure it operates freely.

Table 2-1. Preventive Maintenance Checks and Services (Cont)

NOTE: Within designated interval, these checks are to be performed in the order listed.

INTERVAL DEFINITIONS

Q—Quarterly

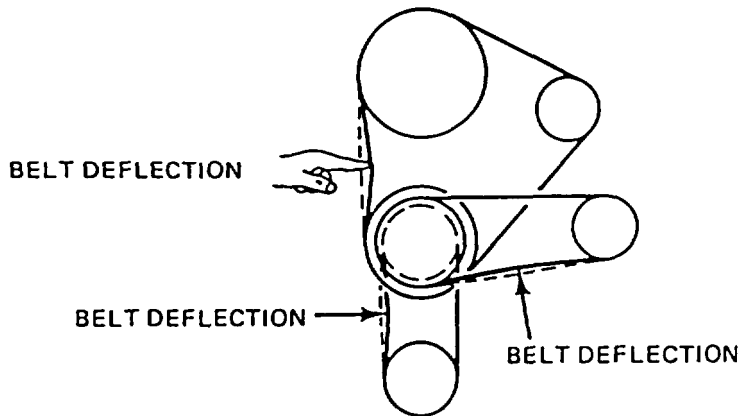
S—Semiannually

A—Annually

Item No.	Interval			Item to be Inspected: Procedure: Check for and have repaired, filled, or adjusted as needed.
	Q	S	A	
19		•		<p>FUEL SYSTEM</p> <ul style="list-style-type: none"> • a. Inspect fuel lines, fuel tank, and fuel system components for leaks and damage. • b. Replace fuel filters (page 4-50).
20				<p>COOLING SYSTEM</p> <p style="text-align: center;">NOTE</p> <p style="text-align: center;">Refer to TB 750-651 for cooling system service.</p> <ul style="list-style-type: none"> • a. Remove debris from cooling fins and check for bent fins. • b. Inspect radiator core for leaks. • c. Check hoses, cap, gaskets, rubber isolator mounts, and fan shroud mounting for cracks and leaks. • d. Inspect water pump for leaks.
21				<p>AIR INTAKE SYSTEM</p> <p style="text-align: center;"><u>WARNING</u></p> <p>If NBC exposure is suspected, all air filter media should be handled by personnel wearing protective equipment. Consult your unit NBC Officer or NBC NCO for appropriate handling or disposal instructions.</p> <ul style="list-style-type: none"> • a. Check air cleaner, hoses, and air cleaner seal for proper installation, cracks, breaks, or loose connections that could let unfiltered air into air intake system. • b. Check air intake screen for debris and damage. • c. Check air intake filter elements for clogging and wear.

Table 2-1. Preventive Maintenance Checks and Services (Cont)

NOTE: Within designated interval, these checks are to be performed in the order listed.

INTERVAL DEFINITIONS

Q-Quarterly

S-Semiannually

A-Annually

Item No.	Interval			Item to be Inspected: Procedure: Check for and have repaired, filled, or adjusted as needed.
	Q	S	A	
22		• • • • • • •		<p>ENGINE</p> <p>a. Check all oil lines, fittings, and hoses for leaks.</p> <p>b. Check oil filter housing, oil pan, and oil pan drain plug for leaks. Notify direct support maintenance if there are any leaks.</p> <p>c. Check valve cover for leaks.</p> <p>d. Check valve clearance (page 4-5).</p> <p>e. Check engine compartment wiring for frays, splits, missing insulation, or poor connections.</p> <p>f. Inspect mounting and attaching hardware for looseness. If mounting hardware is damaged, notify direct support maintenance.</p>
23		• • • •		<p>ELECTRICAL SYSTEM</p> <p style="text-align: center;">NOTE</p> <p style="text-align: center;">Refer to TM 9-6140-200-14 for service and maintenance of batteries.</p> <p>a. Check alternator mounting for looseness. Inspect bracket and attaching hardware for cracks, bends, and loose mounting.</p> <p>b. Check alternator wiring for frays, splits, missing insulation, and loose terminal connections. Replace any broken terminal connections. Notify direct support maintenance for replacement of damaged wiring.</p> <p>c. Check battery cables for frays, splits, and looseness.</p> <p>d. Check battery box for corrosion and debris. Clean batteries and battery box.</p>

Table 2-1. Preventive Maintenance Checks and Services (Cont)

NOTE: Within designated interval, these checks are to be performed in the order listed.

INTERVAL DEFINITIONS

Q-Quarterly

S-Semiannually

A-Annually

Item No.	Interval			Item to be Inspected: Procedure: Check for and have repaired, filled, or adjusted as needed.
	Q	S	A	
24		●		<p>HYDRAULIC SYSTEM</p> <p>Check hydraulic system components for leaks and damage. Check all hoses for wear, pinching, or interference. If any of these conditions are found, replace or reposition hose. Replacement is mandatory for any hose worn or chafed before vehicle use. Replacement is mandatory for any hose that is leaking or has bulges.</p>
25		●		<p>FRONT LOADER OR FORKLIFT</p> <ul style="list-style-type: none"> ● a. Start engine. Cycle each control and check for smooth operation of front loader or forklift. ● b. Inspect mounting and attaching hardware for looseness. ● c. Check hoses, cylinders, and valves for leaks. ● d. Inspect for weld breaks. ● e. Check adjustment of forklift carriage and mast chains (pages 4-559, 4-562).
26		●		<p>BACKHOE OR CRANE</p> <ul style="list-style-type: none"> ● a. Start engine. Cycle each control and check for smooth operation of backhoe or crane. ● b. Inspect mounting and attaching hardware for looseness. ● c. Check hoses, cylinders, and valves for leaks. ● d. Inspect for weld breaks. ● e. Inspect backhoe/crane travel lock for proper operation, cracks, corrosion, and damage.

Table 2-1. Preventive Maintenance Checks and Services (Cont)

NOTE: Within designated interval, these checks are to be performed in the order listed.

INTERVAL DEFINITIONS

Q-Quarterly

S-Semiannually

A-Annually

Item No.	Interval			Item to be Inspected: Procedure: Check for and have repaired, filled, or adjusted as needed.
	Q	S	A	
27				<p>FORKLIFT OR CRANE</p> <p style="text-align: center;"><u>W A R N I N G</u></p> <p>Prior to initial use, new, extensively repaired, or altered forklift or crane must be load tested to prevent injury to personnel.</p> <p style="text-align: center;">NOTE</p> <ul style="list-style-type: none"> • Forklift or crane idle for 1 month or more, but less than 6 months, will be inspected under a Daily Inspection Criteria. Forklift or crane idle for 6 months or more will be inspected under a Periodic Inspection Criteria. • Inspections and testing of forklift or crane will be in accordance with TB 43-0142, dated 14 Jun 82 with Change 2, dated 4 Nov 86, Safety Inspection and Testing of Lifting Devices. <p>• Unit maintenance personnel, assisted by operator/crew personnel, will conduct periodic inspections in accordance with TB 43-0142 with Change 2.</p>
28				<p>VEHICLE EXTERIOR</p> <ul style="list-style-type: none"> • a. Thoroughly inspect for evidence of corrosion damage such as blistered paint, rust-through, or other evidence of damage in accordance with TB 43-0213. • b. Check that following items are in place and in serviceable condition: <ul style="list-style-type: none"> • Fasteners • Hinges • Panels • Stowage Box Doors • c. Check all data plates to ensure legibility. • d. Inspect cab glass, doors, panels, fenders, and brackets for damage.

Table 2-1. Preventive Maintenance Checks and Services (Cont)

NOTE: Within designated interval, these checks are to performed in the order listed.

INTERVAL DEFINITIONS

Q-Quarterly

S-Semiannually

A-Annually

Item No.	Interval			Item to be Inspected: Procedure: Check for and have repaired, filled, or adjusted as needed.
	Q	S	A	
29		•		<p>PINTLE</p> <p>Check pintle hook for proper operation and ensure mounting hardware is tight.</p> <p>FINAL ROAD TEST</p> <p>After all services and inspections have been completed, make sure all corrections have been made.</p>

Section IV. PAINTING AND RESTENCILING MARKINGS

GENERAL

Complete painting of the vehicle is authorized for and done by direct support maintenance or higher. Spot painting and restenciling vehicle markings are done by unit maintenance. Instructions for material preparation and painting are given in TM 43-0139, Painting Instructions for Field Use.

VEHICLE INTERIOR

Prepare surface in accordance with TM 43-0139 and MIL-STD-193.

VEHICLE EXTERIOR

Prepare surface in accordance with TM 43-0139 and MIL-STD-193. Coat surface with color forest green, black, or brown, specification MIL-C-46168.

NONSKID AREAS

Deck covering compound, non-slip, type III, MIL-D-23003 will be used to coat deck areas where personnel walk.

RESTENCILING MARKINGS

All stenciled markings on the SEE/HMMH are black. Use paint conforming to specification MIL-C-46168..

Section V. GENERAL REPAIR AND CLEANING METHOD

OVERVIEW

This section describes general maintenance instructions that apply to all parts of this manual. To avoid repetition, these procedures will not be described in specific maintenance sections.

GENERAL REMOVAL INSTRUCTIONS

1. Work Required. Remove only those parts needing repair or replacement. Do not disassemble a component any further than needed.
2. Preparation. Before removing any part of the electrical, hydraulic, or air systems, make certain system is not energized or pressurized. Disconnect battery cables. Relieve all pressure from air system. Make sure brakes are locked and that all controls are in OFF position before starting any removal procedure.
3. Removal. Make sure there is enough clearance to remove part. Disassemble adjacent parts as needed to provide working clearance.
4. Lifting. Always use chain hoist, jack, or other aid when lifting heavy parts. Make certain load limit of lifting device exceeds weight being lifted. Position and rig lifting device before disconnecting part for removal.
5. Identification. Tag or mark all similar parts, such as electrical leads, before disconnecting and removing such parts. This will make proper assembly easier. Be sure to identify mating ends of electric lines, hydraulic lines, and air tubes as they are disconnected.
6. Position of Valves. Before removing valve handles, mark or diagram their positions when open and closed. This will help during assembly.

GENERAL DISASSEMBLY INSTRUCTIONS

1. Cleanliness. Work area must be kept as clean as possible. This will prevent injury or contamination of internal parts. This is especially true for valves, cylinders, and other hydraulic or air system parts.
2. Expendable Parts. As indicated in this manual, all gaskets, packings, and seals removed during repair must be discarded and replaced with new parts. These items are usually damaged during removal. In the same way, all lockwire, cotter pins, and like items must be replaced at time of assembly.
3. Removing Seals. When removing gaskets, packings, or seals, do not use any metal tool that will scratch the surfaces next to these items.
4. Disassembly. Before disassembly of any item, study the illustration carefully. Note relationship of internal parts. Knowing details of a component will speed up disassembly and assembly and will help avoid mistakes.
5. Parts Protection. To prevent moisture and dirt from entering open housings, lines, and other openings, apply protective caps and plugs as soon as possible after disassembly. Wrap all removed parts in clean paper or coat parts with solid lubricant preservative.

GENERAL CLEANING INSTRUCTIONS

WARNING

- Drycleaning solvent P-D-680 is toxic and flammable. Wear protective goggles and gloves and use only in well-ventilated area. Avoid contact with skin, eyes, and clothes and do not breathe vapors. Do not use near open flame or excessive heat. Flash point is 100° -138°F (38°-50°C). If you become dizzy while using drycleaning solvent, get fresh air immediately and get medical aid. If contact with eyes is made, wash your eyes with water and get medical aid immediately.
- Never use gasoline to clean parts. Gasoline is highly flammable. Serious personal injury could result if fuel ignites during cleaning.

CAUTION

- Petroleum solvents may damage parts that are in contact with hydraulic fluids.
- To prevent damage to equipment, do not clean tires, lubricant seals, rubber hoses, or electrical components with solvent mixture.

1. Cleaning Solvents. Use only approved cleaning solvents to clean parts. Drycleaning solvent SD-2 (P-D-680) is commonly used. Always work in a well-ventilated area.

WARNING

To prevent injury, compressed air used for cleaning and drying purposes will not exceed 30 psi (207 kPa). Use only with effective chip guarding and personal protective equipment (goggles/shield, gloves, etc.).

2. Removing Deposits. After soaking parts in solvent, wash away deposits by flushing or spraying. Where necessary, brush with a soft-bristle brush moistened in solvent. Use compressed air to dry all parts, except bearings. Bearings must be allowed to air dry.
3. Tools. Do not use abrasive wheels, or compounds in cleaning parts, unless called for in detailed instructions. These procedures may weaken a highly stressed part.
4. Ball and Roller Bearings. When cleaning ball or roller bearings, place them in a basket and suspend them in a container of drycleaning solvent. If needed, use a brush to remove bearing before solid particles are removed to prevent damaging races and balls. When bearings have been cleaned, coat them lightly with lubricating oil to remove solvent. Refer to TM 9-214 for additional instructions on cleaning bearings.
5. Rubber Parts. Do not clean rubber parts in drycleaning solvent. Clean by washing with a mild solution of soap and water. Wipe with a clean, dry, lint-free cloth.

WARNING

Steam cleaning creates hazardous noise levels and severe burn potential. Eye, skin, and ear protection are required.

6. Exterior Parts. Steam clean all exterior parts thoroughly before removing. This will make inspection and disassembly easier.

WARNING

- Drycleaning solvent P-D-680 is toxic and flammable. Wear protective goggles and gloves and use only in well-ventilated area. Avoid contact with skin, eyes, and clothes and do not breathe vapors. Do not use near open flame or excessive heat. Flash point is 100° -138° F (38° -50°C). If you become dizzy while using drycleaning solvent, get fresh air immediately and get medical aid. If contact with eyes is made, wash your eyes with water and get medical aid immediately.
- Solvents used with spray gun must be used in spray booth with filter. Face shield must be used by personnel operating spray gun. Failure to do so could result in serious injury to personnel.

7. Engine, Cab, and Body. Use a spray gun and solvent mixture for cleaning exterior of engine, cab, and body. Allow mixture to remain on item surface for about 10 minutes before rinsing. Rinse with hot water under 80-120 pounds of pressure, if available. An ordinary garden hose with nozzle may be used if other equipment is not available. Rinse thoroughly.
8. Degreasing Machine. A degreasing machine may be used to remove heavy grease and oil accumulations from metal parts.
9. Passages. After removing parts from degreasing machine, and before coating with rust preventive, check all oil passages and cavities for dirt or blockage. A thin, flexible wire should be run through oil passages to make certain they are not clogged. Individual passages that are dirty may be cleared using a pressure spray gun and drycleaning solvent.

CAUTION

To prevent corrosion, parts should be dipped in rust preventive compound within 2 hours after degreasing.

10. Electrical Parts. Electrical parts, such as coils, junction blocks, switches, and igniters, which use insulating materials, should not be soaked or sprayed with cleaning solutions. Clean these parts with a clean, lint-free cloth moistened with drycleaning solvent.
11. Electrical Grounds. Clean electrical ground contacts with emery cloth.
12. Oil and Fuel Tank. Pay special attention to all warnings and cautions when working on fuel tank. Oil and fuel tanks should be flushed, using a spray gun and drycleaning solvent.
13. Battery. Exterior surfaces of the electrical system and battery should be cleaned with a weak solution of baking soda and water. Apply solution with a bristle brush to remove corrosion.

GENERAL CLEANING INSTRUCTIONS (CONT)

WARNING

- Drycleaning solvent P-D-680 is toxic and flammable. Wear protective goggles and gloves and use only in well-ventilated area. Avoid contact with skin, eyes, and clothes and do not breathe vapors. Do not use near open flame or excessive heat. Flash point is 100°-138°F (38°-50° C). If you become dizzy while using drycleaning solvent, get fresh air immediately and get medical aid. If contact with eyes is made, wash your eyes with water and get medical aid immediately.

CAUTION

To prevent damage to equipment, never use gasoline or other petroleum-base products to clean or preserve hydraulic system parts.

- 14 Hydraulic System. When cleaning hydraulic system parts, use drycleaning solvent SD-2 (P-D-680). Clean and dry parts thoroughly to make sure no residue remains. If a coating of preservative is required before assembly, apply a light film of solid lubricant preservative. If petroleum-free solvents are not available, use the same hydraulic fluid as used in the hydraulic system.

GENERAL INSPECTION INSTRUCTIONS

1. Sealing Surfaces. Inspect all surfaces in contact with gaskets, packings, or seals. Make sure there are no nicks, burrs, or scratches. If any defect is found, remove or repair it as outlined under General Repair Instructions in this manual.
2. Bearings. Check bearings for rusted or pitted balls, races, or separators. Check balls and races for brinnelling, abrasion, and serious discoloration. Refer to TM 9-214 for additional instructions for bearings. Following are causes for bearing rejection:
 - Cuts or grooves parallel to ball or roller rotation.
 - Fatigue pits (not minor machine marks or scratches).
 - Cracks.
3. Inspection. Inspection consists of checking for defects such as distortion, wear, cracks, and pitting. Parts under heavy load or pressure must be inspected more thoroughly. Clean all parts before inspection.
4. Drain Plugs. When removing drain plugs from transmission, engine, or hydraulic system components, inspect sediment adhering to plug. A buildup of grit and/or fine metal particles may indicate part failure. A few fine particles are normal. This inspection is effective in determining defective parts prior to internal inspection of parts.
5. Gears. Gear inspection cannot be described in detail here: there are too many differences in size and shape of gears. The following steps can be used to make a general visual inspection of all gears. Follow all steps listed in General Repair instructions for final inspection.
 - Normal Wear. Loss of metal from the surface of gear teeth. Wear must not prevent gears from meshing or performing properly.
 - Initial Pitting. This may occur when a pair of gears is first started in service. It may continue until most high spots have been reduced, as long as contact surfaces are not affected. This pitting is not necessarily serious.

- Destructive Pitting. This type of pitting occurs after initial pitting, often at an increasing rate. This will destroy contact area and reduce the gear's ability to carry a load. Rapid destruction will occur with use.
 - Abrasive Wear. This damage is caused by the fine particles that may come from many sources: metal detached from gear teeth or bearings, abrasives not completely removed before assembly, sand or scale from castings, or other impurities in oil or air.
 - Scoring. Slight scoring, scuffing, galling, or other surface damage is identified by tears or scratches in the direction of sliding. It starts in areas having the highest stress and speed. This is usually at the tip of the teeth.
 - Burning. Burning is indicated by discoloration and loss of hardness due to excessive temperature. This is caused by too much friction resulting from overload, overspeed, lack of backlash, or faulty lubrication. If discoloring can be wiped off with clean cloth, such discoloring usually can be traced to oilburn-trains, which are not serious.
 - Rolling. This damage occurs mainly on plastic gears. Rolling is when material is pushed out of shape without breaking off. This is caused by heavy, even loads; sliding; or overheating.
 - Brinelling. This can be identified by tiny indentations or ridges on the shoulder or race of a bearing.
6. Splines. Inspect shaft splines for wear, pitting, rolling, peening, and fatigue cracks. In many cases, the same inspection procedure will apply to gears. However, the problem will often be much less pronounced. Have a magnetic particle inspection performed on splines, if needed.
 7. Tubes, Hoses, Fittings, and Connections. Check all hose surfaces for broken or frayed fabric. Check for breaks caused by sharp kinks or rubbing against other parts of the truck. Inspect air tubes for kinks. Inspect the fitting threads for damage. Replace any part found defective. Following assembly and during initial operation, check for leaking fittings and connections by coating fittings and connections with soap solution. No leakage is permissible.
 8. Electrical Parts. Inspect all wiring harnesses for chafed or burned insulation. Inspect all terminal connectors for loose connections and broken parts.
 9. Metal Parts. Visually inspect all castings and weldments for cracks. Parts that carry a great load should receive magnetic particle inspection. Critical nonferrous parts may be inspected with fluorescent penetrant.
 10. Brake Rotors. Check surfaces of brake rotors for cracks or badly scored finish and for glossy or heat spots. Check brake rotors for external or mating surface cracks and for balancing weight.

GENERAL REPAIR INSTRUCTIONS

WARNING

Drilling and grinding operations are hazardous to the eyes. Eye protection is required.

1. Burrs. Remove burrs from gear teeth with a fine-cut file or hand grinder. Remove burrs on closely fitted mating surfaces by lapping the surfaces with emery cloth.
2. Exterior Parts. Chassis and exterior painted parts may be resurfaced where paint is damaged, or where parts have been repaired, by using an abrasive disc driven by a flexible shaft. Paint metal surfaces as required.
3. Bearings. Remove residue and oil stain from bearing races with emery cloth.

GENERAL REPAIR INSTRUCTIONS (CONT)

NOTE

The following procedure is used with polished and machined steel parts not protected by cadmium, tin, copper, or other plating or surface treatment. Bare metal surfaces must be free of moisture when protective coating is applied.

4. Protective Parts. During repair operations, protect bare steel surfaces from rusting when not actually undergoing repair work. Dip parts in, or spray them with, corrosion preventive compound. The same protective coating may be applied to other metals to prevent rust. Aluminum parts may require protection in atmospheres having a high salt content. Steel parts must always be protected.
5. Welding. Welding and brazing may be used to repair cracks in external steel parts, such as brackets, panels, and light framework. These repairs should be made only when replacement parts are not available. Do not weld or braze castings, running pads, or parts under great stress, except in emergencies. When welding is required, refer to TM 9-237.
6. Stud Installation. When installing studs in engine block and axle housings, use a driver designed for the stud to be installed. A worn stud driver may damage the end thread. This makes it necessary to use a chasing die before a nut can be screwed on. This procedure will remove cadmium plating and allow corrosion, which will make future disassembly difficult and cause stud to be backed out with nut. Before driving a stud, inspect hole for chips and liquid. Blow out any foreign matter. Start stud by hand. If it will not start into hole, it is too large or has defective end thread. Before final insertion, coat thread with antiseize compound; turn stud in slowly to prevent overheating and galling of casting metal.
7. Electrical Parts. Replace all broken, worn, or burned electrical wiring. Wires with several broken strands must be replaced. Broken strands will increase the resistance of the wire and impair efficiency of electrical components, especially the ignition system. When soldering is required, refer to TB SIG 222.
8. Hoses. Replace all broken, frayed, crimped, or soft flexible lines and hoses. Replace stripped or damaged fittings. Replace entire flexible hose if fittings are damaged. Make sure hose clamps do not crimp hoses.
9. Fasteners. Replace any bolt, screw, nut, or fitting with damaged threads. Inspect tapped holes for thread damage. If cross-threading or galling is evident, retap the holes for the next oversize screw or stud. When retapping will weaken the part, or when the cost of the part makes retapping impractical, replace the damaged part. Chasing threads with the proper size tap or die may often be enough.
10. Dents. Straighten minor body dents by bumping with a soft-faced hammer while using a wooden block backing.
11. Sheet Metal Repair. Repair minor skin cracks by installing patches.
12. Mounting Holes. Reshape oval mounting holes to round. Drill to receive bushing with required inner diameter. Stake bushing in place with center punch.

GENERAL ASSEMBLY INSTRUCTIONS

1. Preparation. Remove grease from new parts before installation.
2. Packing Installation. Lubricate all packings with a thin coating of light lubricating oil before installation. Slightly stretch packing and place into position. Rotate component on flat surface or uniformly press the packing into position.
3. Pipe Joints. Use sealing pipe-joint compound or thread sealing tape when joining piping.
4. Gaskets. To provide added sealing for gasket, coat both sides with sealant. Remove all traces of previous gasket and sealant before installing new gasket.
5. Silicone Sealant (Sealing Compound).

WARNING

On direct contact, uncured silicone sealant irritates eyes. In case of contact, flush eyes with water and seek medical attention. Avoid prolonged contact with skin.

Silicone sealant is often used instead of a gasket to seal mating parts. Mating parts must be clean, dry, and free of oil or grease for proper adhesion. After silicone sealant has been applied, mating parts must be assembled within 15 minutes. Silicone sealant starts to set up in 15 minutes and takes 24 hours to completely cure. Excess silicone sealant should be wiped off after assembling mating parts.

6. Oil Seals. Install oil seals with seal lip facing toward lubricant, applying an even force to outer edge of seal. Coat oil seals evenly with grease before installing. If oil seals will be installed over keyed or splined shafts, use a guide. This will prevent sharp edge of keyway or splines from cutting the leather or neoprene seal. Construct guides of very thin-gage sheet metal and shape to required diameter. However, make certain guide edges are not sharp. Bend them slightly inward so they do not cut the seal.
7. Seal Rings. Coat seal rings with oil and carefully install into their bores. If seal rings must be installed over threaded parts, temporarily wrap the threads with tape to protect the seal ring.
8. Bearings and Shafts. During assembly of shafts and bearings in housings, first mount bearing on shaft, then install the assembly by applying force to shaft. When mounting bearings on shafts, always apply force to the inner races of the bearing.
9. Bearing Lubrication. Lubricate bearings before reassembly with the type of lubricant normally used in the related housing or container. This will provide lubrication during the first run-in until lubricant from the system can reach the bearings.

GENERAL INSTALLATION INSTRUCTIONS

1. Preparation. Before installing any parts, make sure they are clean and that both mounting surfaces are clean and free of oil and grease (unless otherwise noted).
2. Installation. Make sure there is enough clearance to install part. Disassemble adjacent parts as needed to provide working clearance.
3. Lifting. Always use chain hoist, jack, or other aid when lifting heavy parts. Make certain load limit of lifting device exceeds weight being lifted. Position and rig lifting device before connecting part for installation.

GENERAL LUBRICATION INSTRUCTIONS

Keep a light coat of lubricating oil on parts during repair procedures to prevent rusting. Lubricate parts during repair and assembly as required by LO 5-2420-224-12.

GENERAL TORQUE VALUE INSTRUCTIONS

Use the torque values listed in the maintenance procedures, if they are given. When no torque values are given in the maintenance procedures, refer to the torque value guide in Appendix E.

PREPARATION FOR MAINTENANCE

Some maintenance tasks are necessary to prepare the SEE/HMMH for many of the maintenance procedures in Chapter 4. These tasks are required for personnel safety and for ease of maintenance. These preparation steps are described below.

BLOCKING THE VEHICLE

During maintenance procedures, the vehicle wheels must be chocked to prevent roll off. Chock all wheels both in front and behind each wheel.

THREE-POINT STANCE (SEE)

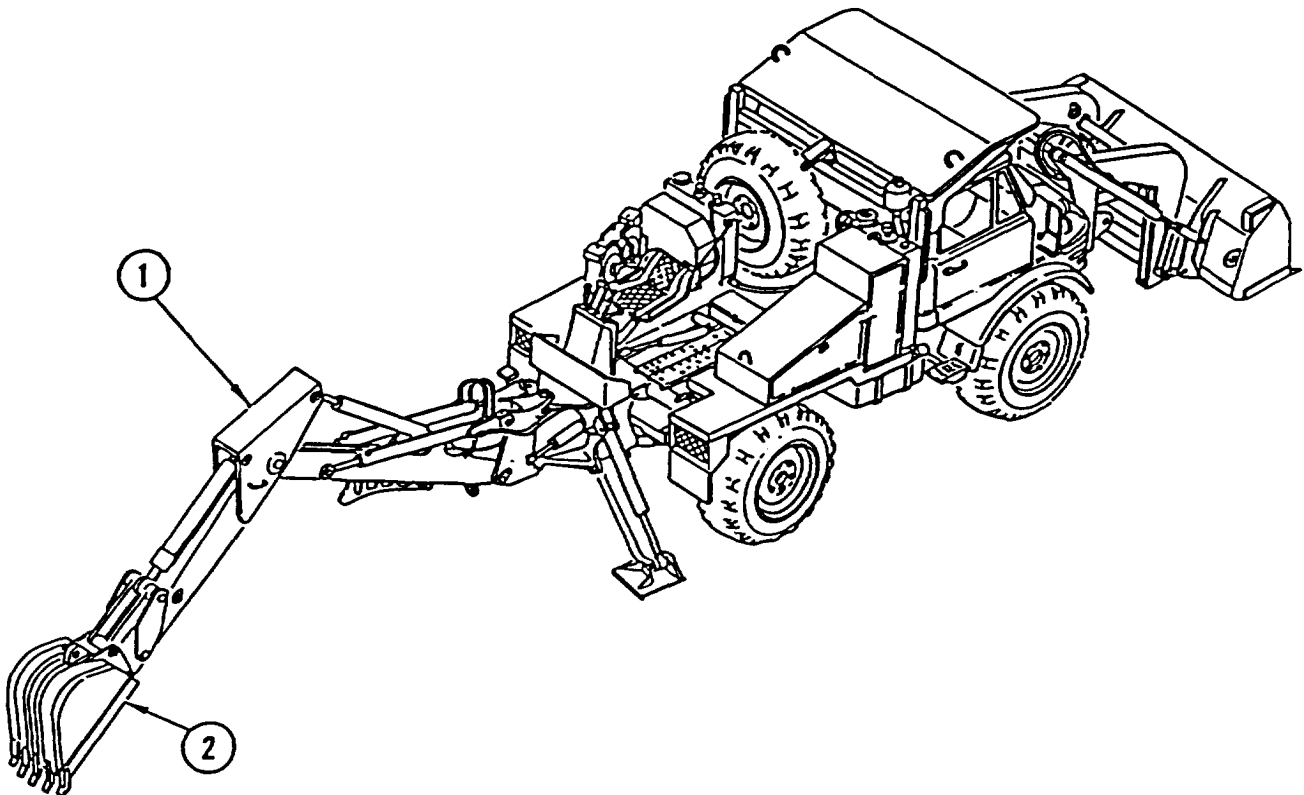

To perform some maintenance procedures, the backhoe must be placed in a three-point stance (1). The bucket (2) may be extended as shown, or rolled under. The amount of extension will depend on the task being performed.

THREE-POINT STANCE (HMMH)

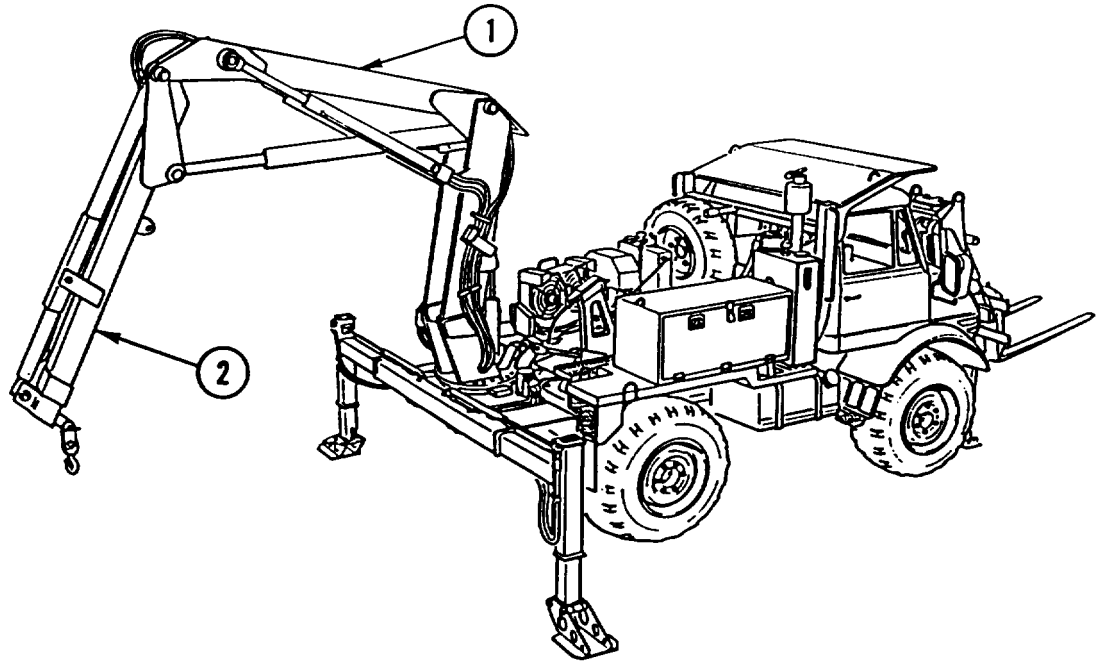

To perform some maintenance procedures, the crane must be placed in a three-point stance (1). The outer boom (2) is positioned on the ground using caution not to damage hook on boom end. The amount of extension will depend on the task being performed.

RELIEVING HYDRAULIC PRESSURE

Turn engine off. Move control levers in both directions 3-4 times.

RELIEVING AIR PRESSURE

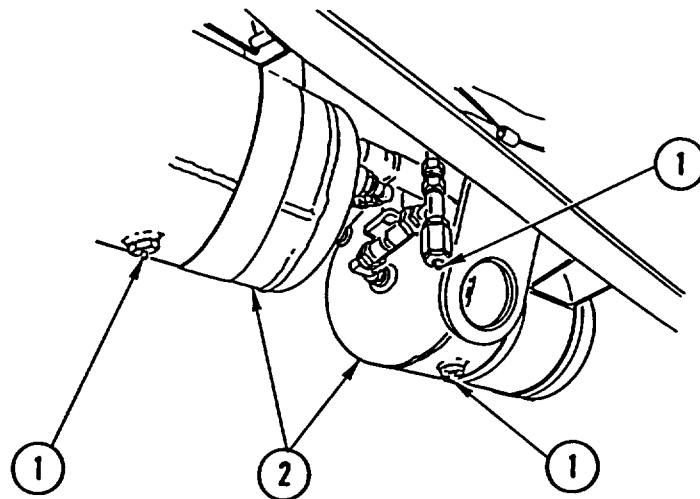

Turn engine off. Depress air relief valves (1) and hold until all air has escaped from air tanks (2).

DISCONNECTING/CONNECTING BATTERIES

DISCONNECT

WARNING

All vehicle electrical switches must be OFF before disconnecting battery cables. Failure to do so could result in injury to personnel.

NOTE

Procedure is the same for all batteries.

1. Remove cover (1) from battery terminal (2).
2. Loosen nut (3) and remove cable (4) from battery terminal (2).

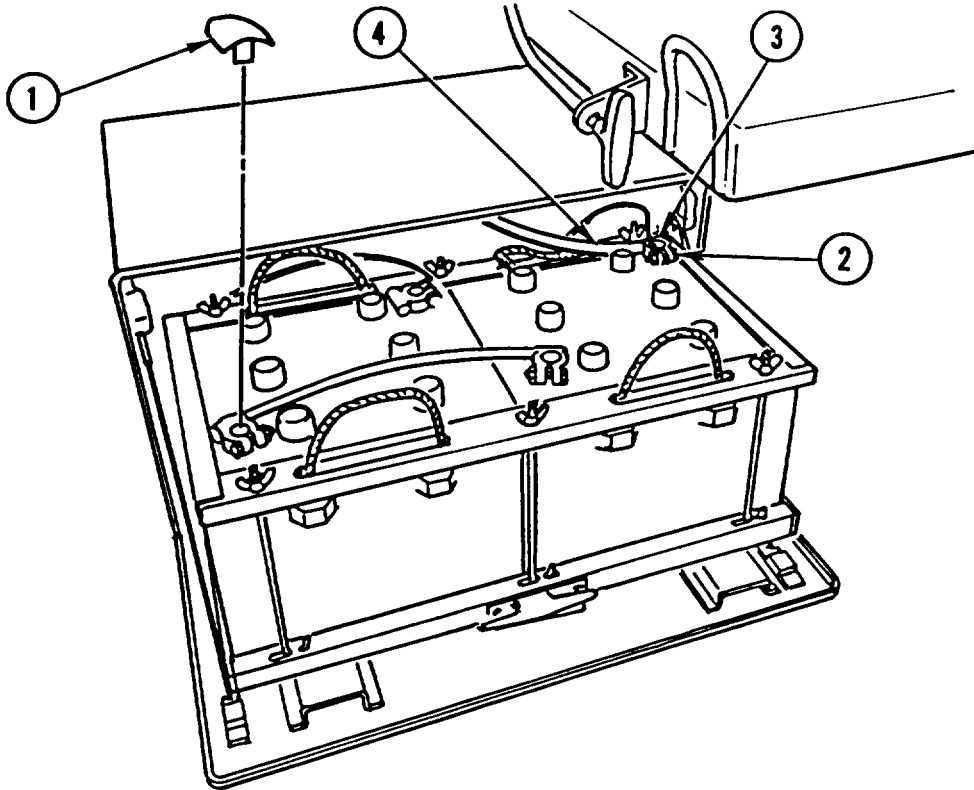

CONNECT

NOTE

Procedure is the same for all batteries.

1. Install cable (4) on battery terminal (2) and tighten nut (3).
2. Install cover (1) on battery terminal (2).

TUBE FITTINGS REPLACEMENT

REMOVAL

WARNING

Do not disconnect any air system lines or fittings unless vehicle engine is shut off and air system pressure is relieved. To do so could result in injury to personnel.

NOTE

Steps 1 thru 3 are for compression fittings. Step 4 is for banjo type fittings.

1. Remove nut (1) from fitting (2).
2. Remove air tube (3) from fitting (2).

NOTE

If insert remains in fitting, do not remove.

3. Remove insert (4), ferrule (5), and nut (1) from air tube (3).
4. Remove fitting (6) from tube (7).

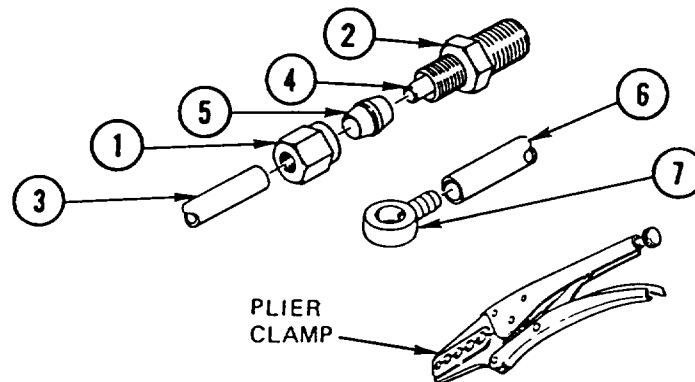

INSTALLATION

NOTE

- Steps 1 thru 3 are for compression fittings. Steps 4 and 5 are for banjo type fittings.
- Cut new tube 1/4-1/2 in. (6.4 -12.7 mm) longer than air tube being replaced.

1. Install nut (1), ferrule (5), and insert (4) on air tube (3).
2. Install air tube (3) in fitting (4).
3. Install nut (1) on fitting (2).
4. Hold tube (6) in plier clamp.
5. Install fitting (7) in tube (6) and drive in as far as it will go using plastic headed hammer.

VEHICLE TOWING (SEE)

TOW BAR INSTALLATION

WARNING

- Tow bar weighs 120 pounds (55 kilograms). To avoid personal injury, always use two or more personnel to install tow bar.
- To avoid personal injury, do not allow any part of body to get between tow bar and front loader bucket.

1. Place front loader bucket in transport position (TM 5-2420-224-10).
2. Set parking brake (TM 5-2420-224-10) and block vehicle (page 2-22).

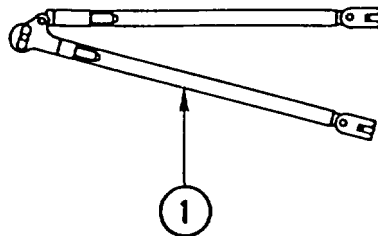

3. Prepare tow bar (1) (FM 20-22).

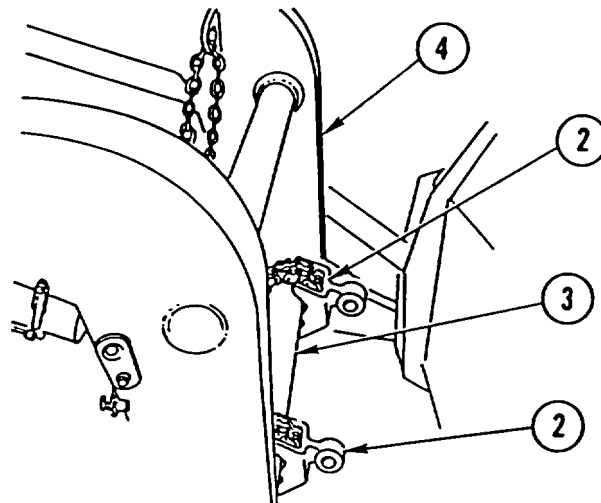

4. Attach two clamps (2) to crossbar (3) of front loader (4), perpendicular to ground to allow for clearance when turning.

VEHICLE TOWING (SEE) (CONT)

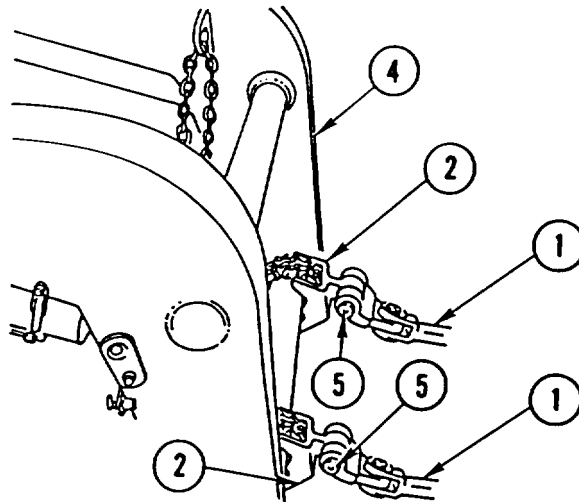

5. Attach tow bar (1) to two clamps (2) using 1.0-in. (24.4-mm) pin and clevis assemblies (5), with clevis tipping upward.

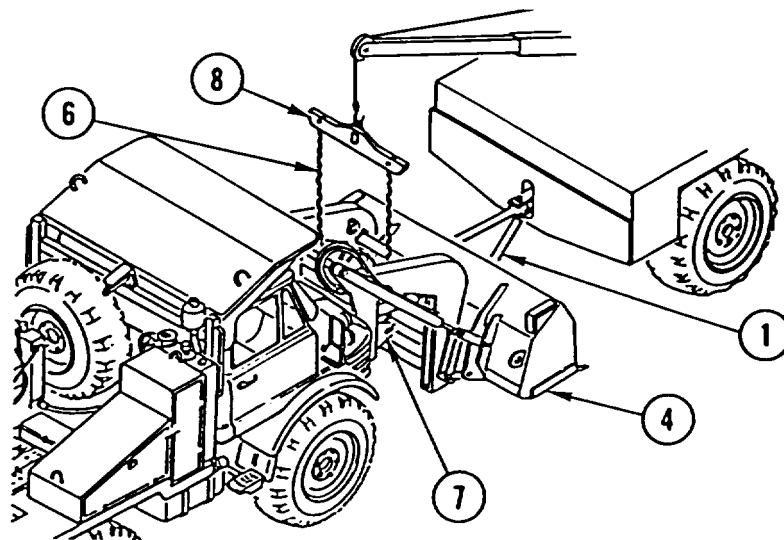

6. Extend tow bar (1) enough to clear front loader (4) and tow vehicle when turning.
7. Attach lift chains (6) to front lift points (7) and spreader bar (8).
8. Raise front loader (TM 5-2420-224-10) to allow access to tow bar connection to wrecker.
9. Attach tow bar (1) to wrecker.
10. Move wrecker boom forward or backward to obtain proper boom-to-vehicle alignment.
11. Connect spreader bar (8) to wrecker boom. Raise front of vehicle until tires are 10-12 in. (24.4-30.4 cm) off ground.
12. Place main shift lever in neutral, shift intermediate speed control in position H, Power Take-Off in neutral, range-shift lever in stage II, and disengage four-wheel drive lever (TM 5-2420-224-10).

VEHICLE TOWING (SEE) (CONT)

13. Release parking brake (TM 5-2420-224-10) and remove chocks.
14. Lower front loader, engage lock, and close shutoff valve (TM 5-2420-224-10).

TOW BAR REMOVAL

WARNING

- Tow bar weighs 120 pounds (55 kilograms). To avoid personal injury, always use two or more personnel to remove tow bar.
- To avoid personal injury, do not allow any part of body to get between tow bar and front loader bucket.

1. Set parking brake (TM 5-2420-224-10) and block vehicle (page 2-22).
2. Lower vehicle to ground.
3. Open shutoff valve, disengage lock, and raise front loader (TM 5-2420-224-10) to allow access to tow bar connection to wrecker.

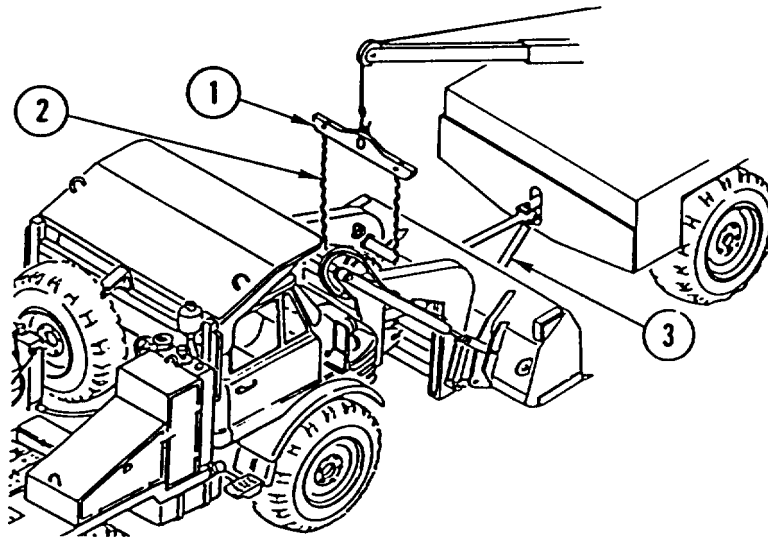

4. Remove spreader bar (1), disconnect lift chains (2), and disconnect tow bar (3) from wrecker.

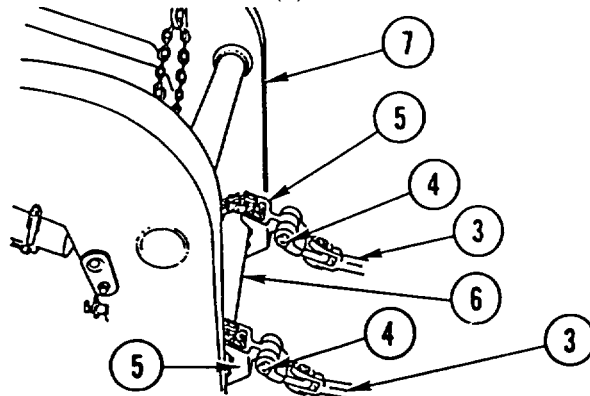

5. Remove pin and clevis assemblies (4) and tow bar (3) from two clamps (5).

VEHICLE TOWING (SEE) (CONT)

6. Remove two clamps (5) from crossbar (6) of front loader (7).
7. Lower front loader, engage lock, and close shutoff valve (TM 5-2420-224-10).

VEHICLE TOWING (HMMH)**TOW BAR INSTALLATION****WARNING**

- Tow bar weighs 120 pounds (55 kilograms). To avoid personal injury, always use two or more personnel to remove tow bar.
- To avoid personal injury, do not allow any part of body to get between tow bar and forklift.

1. Place forklift in transport position (TM 5-2420-224-10).
2. Set parking brake (TM 5-2420-224-10) and block vehicle (page 2-22).

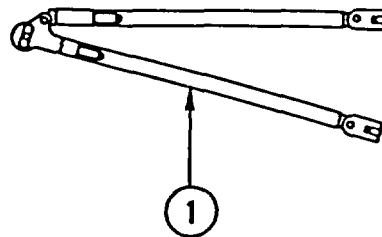

3. Prepare tow bar (1) (FM 20-22).

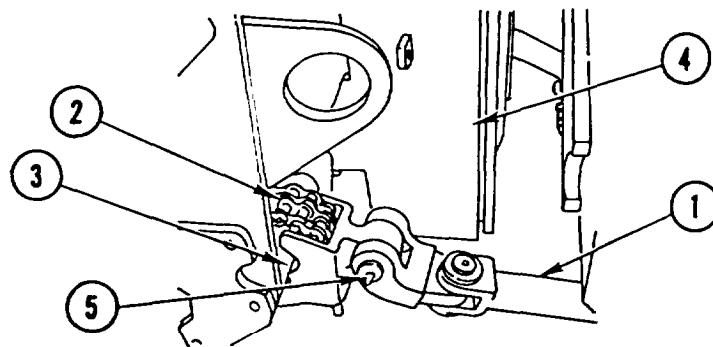

4. Attach two clamps (2) to crossbar (3) of forklift (4), perpendicular to ground to allow for clearance when turning.
5. Attach tow bar (1) to two clamps (2) using 1.0-in. (24.4-mm) pin and clevis assemblies (5).
6. Extend tow bar (1) enough to clear forklift (4) and tow vehicle when turning.

VEHICLE TOWING (HMMH) (CONT)

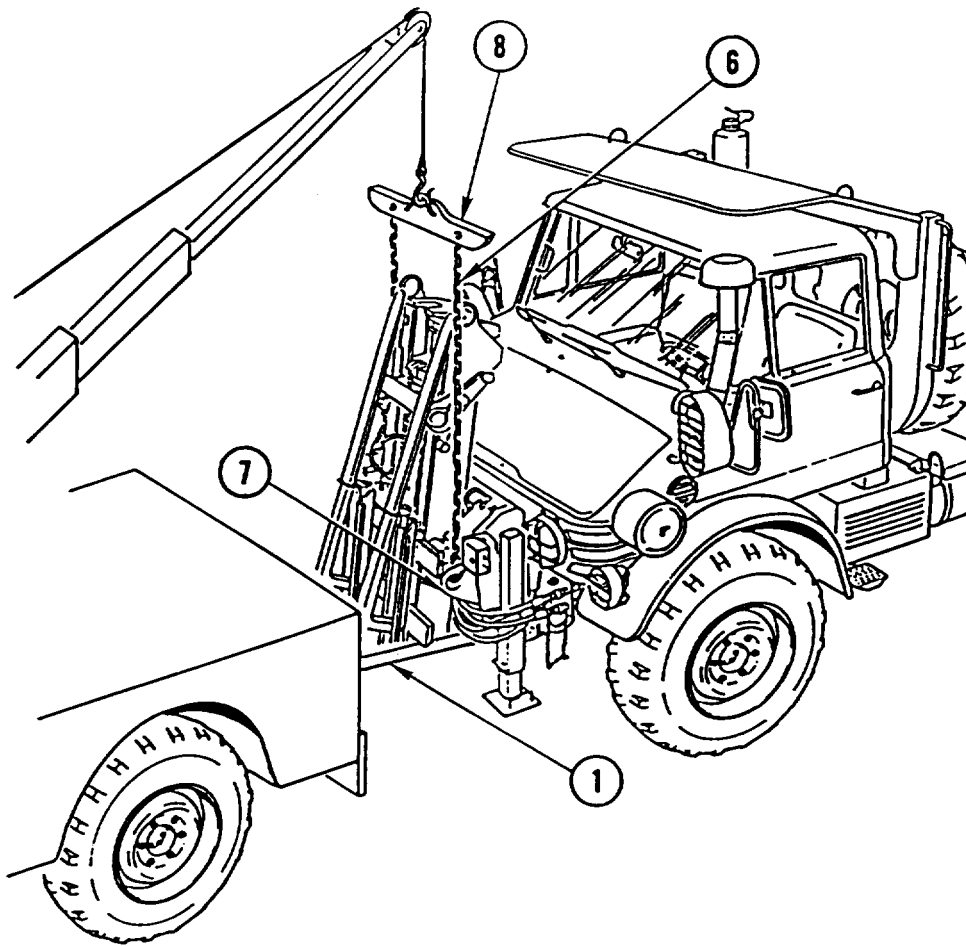

7. Attach lift chains (6) to front lift points (7) and spreader bar (8).
8. Attach tow bar (1) to wrecker.
9. Move wrecker boom forward or backward to obtain proper boom-to-vehicle alignment.
10. Connect spreader bar (8) to wrecker boom. Raise front of vehicle until tires are 10-12 in. (24.4-30.4 cm) off ground.
11. Place main shift lever in neutral, shift intermediate speed control in position H, Power Take-Off in neutral, range-shift lever in stage II, and disengage four-wheel drive lever (TM 5-2420-224-10).
12. Release parking brake (TM 5-2420-224-10) and remove chocks.
13. Close shutoff valve (TM 5-2420-224-10).

VEHICLE TOWING (HMMH) (CONT)

TOW BAR REMOVAL**WARNING**

- Tow bar weighs 120 pounds (55 kilograms). To avoid personal injury, always use two or more personnel to remove tow bar.
- To avoid personal injury, do not allow any part of body to get between tow bar and forklift.

1. Set parking brake (TM 5-2420-224-10) and block vehicle (page 2-22).
2. Lower vehicle to ground.
3. Open shutoff valve (TM 5-2420-224-10).

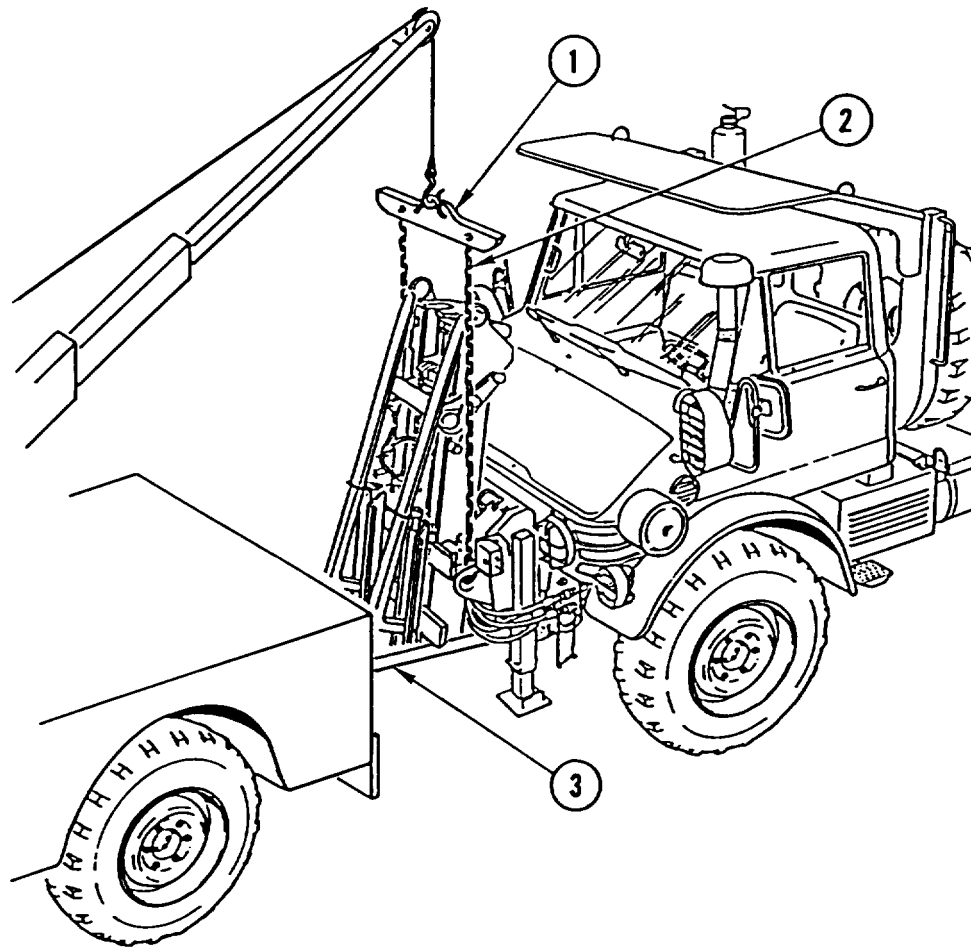

4. Remove spreader bar (1), disconnect lift chains (2), and disconnect tow bar (3) from wrecker.

VEHICLE TOWING (HMMH)(CONT)

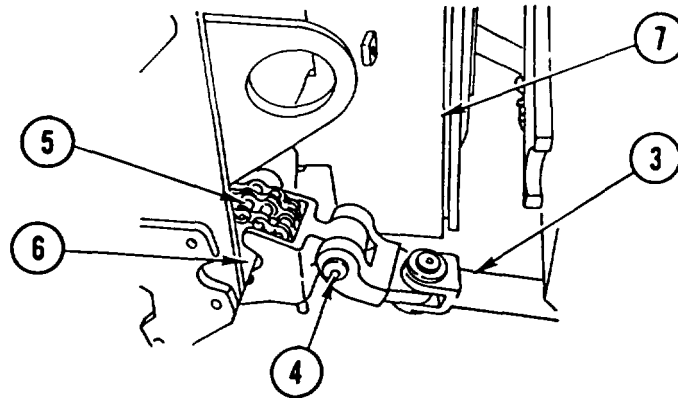

5. Remove pin and clevis assemblies (4) and tow bar (3) from two clamps (5).
6. Remove two clamps (5) from crossbar (6) of forklift (7).
7. Close shutoff valve (TM 5-2420-224-10).

Section VI. GENERAL HYDRAULIC SYSTEM REPAIR METHODS

OVERVIEW

This section contains repair methods for the hydraulic system. If special repair methods or procedures are required for the hydraulic system or related parts, these methods or procedures are included in the individual maintenance procedures in Chapter 4.

GENERAL REPAIR METHODS

WARNING

High pressure hydraulics [oil under 2450 psi (16,893 kPa)] operate this equipment. Never disconnect any hydraulic line or fitting without first dropping pressure to zero. A high pressure oil stream can pierce body and cause severe injury to personnel.

CAUTION

- Always clean around fittings before disconnecting or connecting hose of fittings. Make sure area is clean before installing hydraulic components. Failure to do so could result in damage to equipment.
- Cover, cap, or plug all openings, ports, and tube or hose ends when disconnected. Failure to do so could result in damage to equipment.

GENERAL REPAIR METHODS (CONT)

CAUTION

- Mate a fitting only with a fitting designed to mate. Because two fittings will screw together is no guarantee they will not leak. Never depend on trial and error. To do so could result in damage to equipment.
- Fittings must be installed and hand-tightened. If a fitting cannot be hand-tightened, it may be cross-threaded or have damaged threads. Use wrench only for final tightening. Failure to do so could result in damage to equipment.
- Do not use pipe dope as sealer on any fitting. Pipe dope can separate from fittings causing control valves and relief valves to become contaminated and fail.
- It is possible to screw a male NPT into a female straight thread, but fitting will leak. NPT has a slight taper.
- Do not attempt to use parts of a 37-degree flare fitting and a flareless fitting with each other. Fitting will leak.
- When connecting NPTs, use care not to overtighten. If overtightened, female pipe thread will split.
- Do not apply sealant to first thread of NPT fitting. If sealant enters hydraulic system, it may cause components to fail.
- Be careful when installing preformed packings. Sharp threads can nick packing, causing it to leak.
- Do not overtighten a flareless connection. Overtightening can cause leakage requiring replacement of entire tube assembly.
- When connecting a hose to fitting, always use two wrenches. Use one wrench to turn swivel nut onto fitting and other wrench to keep hose or tube from rotating. Failure to do so could result in damage to equipment.

The following describes the types of fittings used in the vehicles. Refer to this information when performing hydraulic maintenance tasks.

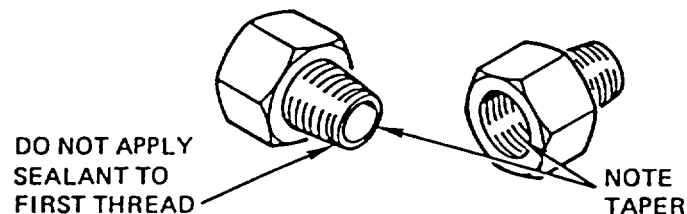

NATIONAL PIPE THREAD (NPT)

1. National Pipe Thread (NPT). This thread differs from others in that it is tapered. To obtain a proper seal with NPT, a sealant must be used. The sealant should be applied to male threads. Use care not to overtighten.

GENERAL REPAIR METHODS (CONT)

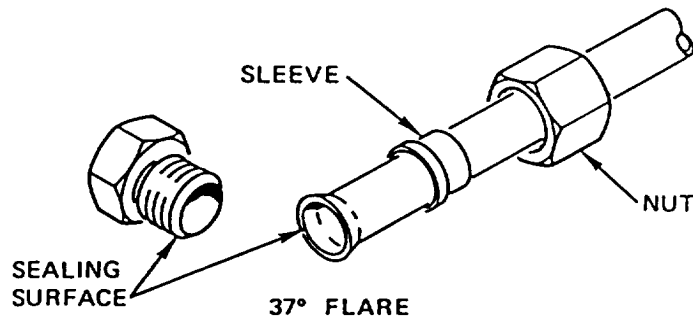

2. 37-Degree Flare. The 37-degree flare connection has a male straight thread that mates with a female straight thread. The sealing surface for this connection is the angled nose at the end of the male fitting. The nose mates with a similar surface in the female 37-degree flare fitting. These sealing surfaces must be free of nicks and scratches to seal properly.

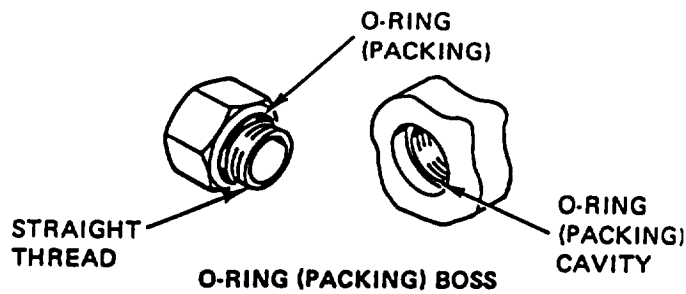

3. O-Ring (Preformed Packing) Boss. The boss connection has a straight thread. The seal for this connection has a preformed packing that fits on top of the thread. This packing is squeezed in the extra space at the top of the female thread and seals the connection.

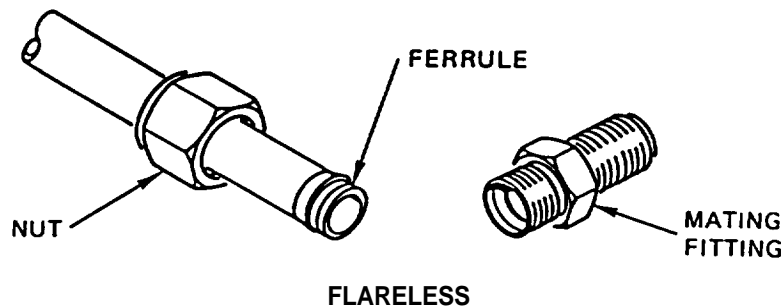

4. Flareless. This fitting has a straight thread. The female fitting contains a ferrule that mates with a cavity in the male fitting. Use care not to overtighten to avoid damage to the ferrule.

5. Installation of Preformed Packings.

- a. Before installing a new packing, inspect threads and packing seat for nicks, cracks, and distortion.
- b. Make sure the packing is correct type and size. If not sure, check Repair Parts and Special Tools List (TM5-2420-224-24P).
- c. Before installing a new packing, apply coat of lubricating oil to packing (Appendix C, Item 22).

GENERAL REPAIR METHODS (CONT)

- d. When installing a packing, always protect it from cuts or nicks. Do not install packing directly over threads. If available, install packing over a plastic or rubber thread guard supplied with new fittings. If no thread guard is available, protect packing by wrapping fitting threads with heavy, smooth, lint-free paper or tape.
 - e. If a backup washer is used with the packing, it must be free of cuts, nicks, and distortion. An unserviceable backup washer can cause packing to distort or rupture when hydraulic pressure is applied, resulting in a leak.
 - f. Always make sure packing is not damaged, twisted, or distorted after installation.
6. Installation of Adjustable Fittings.
- a. Apply coat of lubricating oil (Appendix C, Item 22) to new packing.

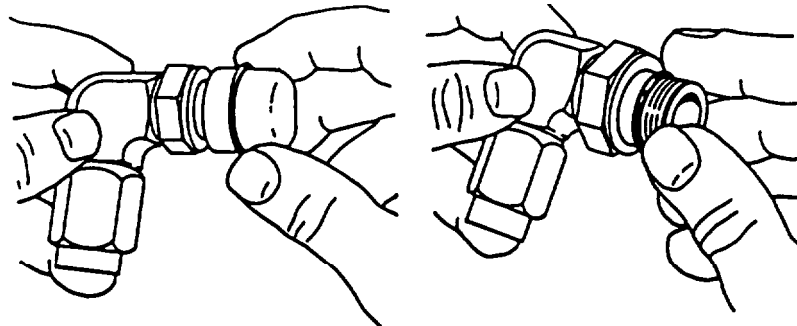

CORRECT METHOD

INCORRECT METHOD

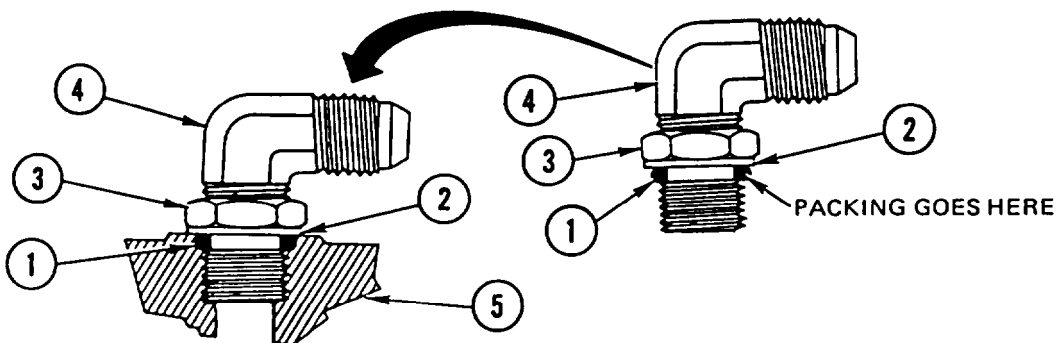

CAUTION

Packing must be located in groove and not on threads to prevent damage to packings.

- b. Using suitable thread guard, install packing (1) and backup washer (2) in groove.
- c. Turn lock nut (3) down until lock nut just contacts backup washer (2).
- d. Install fitting (4) in boss (5) until backup washer (2) makes contact with boss.
- e. Position fitting (4) in desired position by backing fitting out up to one full turn. Hold fitting (4) in desired position and tighten lock nut (3).

Section VII. PREPARATION FOR STORAGE OR SHIPMENT

OVERVIEW

This section describes how to prepare vehicles for temporary storage and remove them from temporary storage.

ENTERING VEHICLES INTO TEMPORARY STORAGE

NOTE

Vehicles enter storage phases predicated on length of storage period and maintenance services required.

1. Phase I Preservation Tasks (Up to 30 Days):
 - a. Place front loader and backhoe (SEE) or forklift and crane (HMMH) in transport position (TM 5-2420-224-10) with safety valves closed.
 - b. Retract hydraulic piston rods into cylinders as far as possible. Clean and coat all exposed portions of attachment cylinders and hydraulic spool valves with solid lubricant preservative (Appendix C, Item 21). Exposed portions include:
 - Front loader lift cylinders (SEE)
 - Forklift lift, tilt, and rotating cylinders (HMMH)
 - Backhoe dipper, bucket, boom, swing, stabilizer, and tilt cylinders (SEE)
 - Crane external end extension, inner boom lift, mast locking, outer boom, and outrigger cylinders (HMMH)
 - Front loader/forklift control valve spools
 - Tilt and latch control valve spools
 - Backhoe control valve spools (SEE)
 - Crane valve bank spools (HMMH)
 - c. Coat tools with solid lubricant preservative (Appendix C, Item 21):
 - Three carbide bits (SEE)
 - Clay spade (SEE)
 - Moil point (SEE)
 - Chisel point (SEE)
 - Set of impact sockets (HMMH)
 - 48-oz (1.4-kg) hammer
 - Adjustable wrench
 - Pinch bar
 - d. Coat five hydraulic and chassis toolbox hinges with solid lubricant preservative (Appendix C, Item 21).
 - e. Add diesel fuel additive (Appendix C, Item 1).

ENTERING VEHICLES INTO TEMPORARY STORAGE (CONT)
--

2. Phase II Preservation Tasks (After 30 Days):

- a. Operate engine for 6 minutes.
- b. Operate all lights and switch functions.
- c. Check fluid levels (LO 5-2420-224-12).
- d. Operate hydraulic controls:
 - Front loader boom and bucket (SEE)
 - Forklift raise-lower, tilt, and rotate (HMMH)
 - Backhoe dipper, bucket, boom, swing, stabilizer, and tilt (SEE)
 - Crane external end extension, inner boom lift, mast locking, outer boom, and outrigger (HMMH)
 - Hammer drill, pavement breaker, and chain saw (SEE)
 - Impact wrench (HMMH)
- e. After operating hydraulic controls, coat all cylinders and spools with solid lubricant preservative (Appendix C, Item 21).
- f. Drive vehicle through all gear ranges and shift selector positions.
- g. Apply brakes [two panic stops at vehicle speed of 20 mph (32 kPh)].
- h. Check for Class III leaks. Repair as required.
- i. Add diesel fuel additive (Appendix C, Item 1).

3. Phase III Operational Tasks (After 90 Days):

- a. Perform Phase II Preservation Tasks.
- b. Apply lubricant to lubrication points (LO 5-2420-224-12).
- c. Check fan belt, front hydraulic pump belt, and power steering pump belt for cracks and proper tension.
- d. Check for and replace any windshield wiper blades (page 4-482), tires (page 4-337), and rubber grommets and door and window seals (page 4-393) that show signs of weathering/deterioration.
- e. Check air cleaner elements for contamination (page 4-35).
- f. Bleed brake system (page 4-262).
- g. Clean fuel filters (page 4-48).
- h. Check that backhoe boom latch (SEE)/crane travel lock (HMMH) operate freely.
- i. Check that hose reel motor spring operates freely.
- j. Check that exhaust weather cap operates freely.
- k. Relieve air pressure (page 2-23).

REMOVING VEHICLES FROM TEMPORARY STORAGE

1. Wash and clean both interior and exterior of vehicle.
2. Perform PMCS (page 2-2).
3. Inspect for oil leaks. Repair as required.
4. Inspect for rust and deteriorated paint. Sand and paint as required (page 2-14).
5. Add diesel fuel additive (Appendix C, Item 1).

CHAPTER 3 TROUBLESHOOTING

SCOPE

This chapter contains information you need to troubleshoot the SEE/HMMH. It includes information on use of electrical test equipment, harness and wire repair, use of Simplified Test Equipment for Internal Combustion Engines-Reprogrammable (STE/ICE-R), a malfunction symptom index, and troubleshooting charts. The following sections are included in this chapter:

	Page
Section I. Using Electrical Test Equipment	3-1
Section II. Wiring Harness and Wire Repair	3-11
Section III. Using STE/ICE-R With the Tractor	3-17
Section IV. Troubleshooting Procedures	3-63

Section I. USING ELECTRICAL TEST EQUIPMENT

OVERVIEW

This section shows how to use a multimeter to find the causes of electrical problems that may develop in the vehicle. The three multimeters that are usually included in unit maintenance shop kits are:

- TS-352 B/U
- AN/PSM-45
- Simpson Model 160

All of these multimeters do the same thing. This section shows how to test AC and DC voltages with these multimeters. These multimeters are used to check components for continuity, shorts, open circuits, and AC and DC voltages. The STE/ICE-R can also be used as a multimeter.



AN/PSM-45

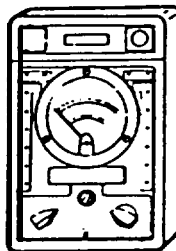

TS-352 B/U

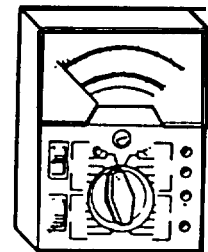

SIMPSON 160

USING THE OHMS SCALE

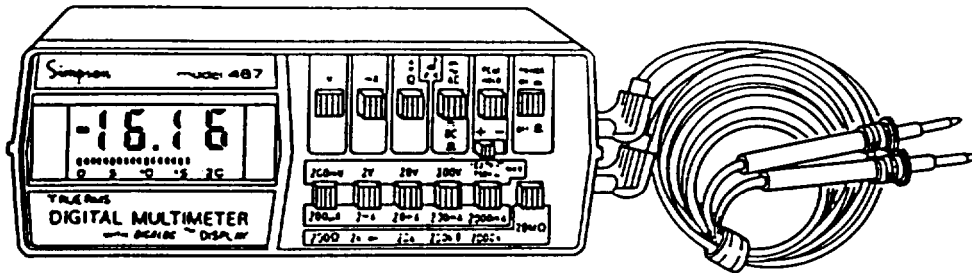

Use the ohms (Ω) scale when testing electrical circuits for continuity, short circuits, and poor connections (high resistance). You must zero the multimeter before making continuity or resistance tests. The following procedures tell and show how to zero two of the three multimeters. The AN/PSM-45 zeroing procedure is contained in TM 11-6625-3052-14.

ZEROING THE AN/PSM-45 MULTIMETER

NOTE

For accurate readings, do not touch probe ends with fingers while zeroing the multimeter.

Refer to TM 11-6625-3052-14 for operating instructions for the AN/PSM-45 multimeter.

USING THE OHMS SCALE (CONT)

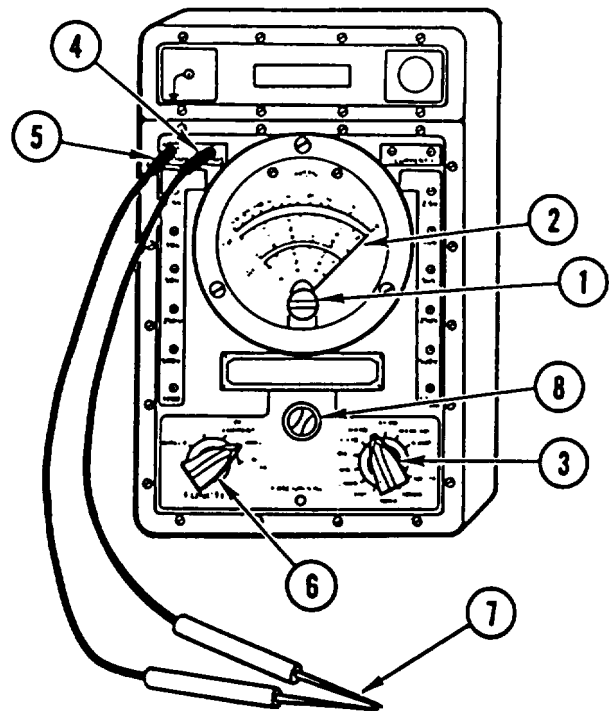

ZEROING THE TS-352 B/U MULTIMETER

NOTE

For accurate readings, do not touch probe ends with fingers while zeroing the multimeter.

1. Using adjusting screw (1), set needle (2) to infinity (∞) prior to OHMS ZERO ADJ.
2. Set RANGE switch (3) to RX100.
3. Plug black (-) lead (4) in OHMS DC \pm jack.
4. Plug red (+) lead (5) in upper left OHMS jack.
5. Set FUNCTION switch (6) to OHMS.
6. Hold two probe tips (7) firmly together.

NOTE

If needle will not zero, replace batteries in multimeter. If needle still will not zero, have multimeter repaired.

7. Zero multimeter by turning OHMS ADJ knob (8) until needle (2) is over 0 on OHMS scale.

USING THE OHMS SCALE (CONT)

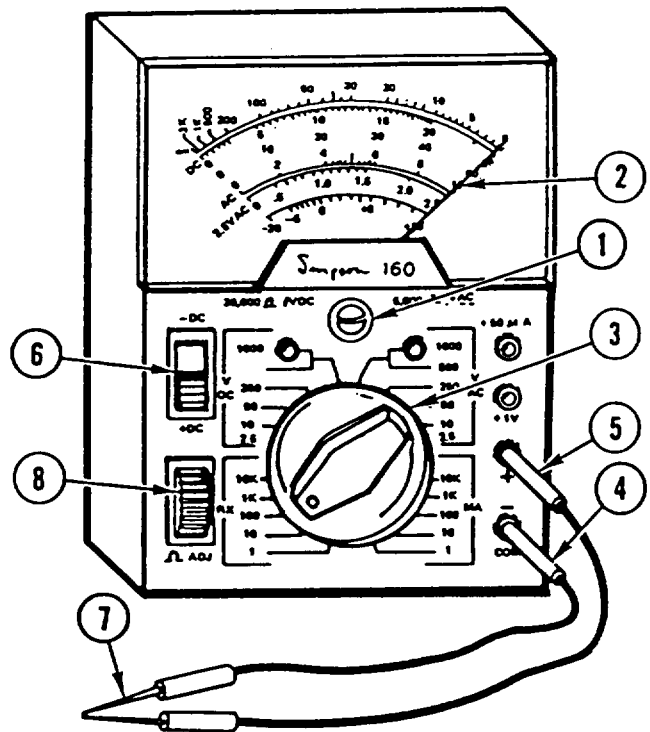

ZEROING THE SIMPSON MODEL 160 MULTIMETER

NOTE

For accurate readings, do not touch probe ends with fingers while zeroing the multimeter.

1. Using adjusting screw (1), set needle (2) to infinity (∞) prior to OHMS ZERO ADJ.
2. Set selector switch (3) to RX100.
3. Plug black (-) lead (4) in COM jack.
4. Plug red (+) lead (5) in +jack.
5. Set +DC/-DC switch (6) to +DC.
6. Hold two probe tips (7) firmly together.

NOTE

If needle will not zero, replace batteries in multimeter. If needle still will not zero, have multimeter repaired.

7. Zero multimeter by turning OHMS ADJ knob (8) until needle (2) is over 0 on OHMS scale.

TESTING FOR CONTINUITY

Continuity tests are made to check for open circuits (breaks or disconnections) in leads, harnesses, connectors, and switches. Follow the instructions below to make a continuity check.

NOTE

The TS-352 B/U multimeter is shown in these instructions, but the procedures are similar for any of the multimeters.

1. Set and zero multimeter for OHMS RX1.

CAUTION

The multimeter can be damaged unless power is removed from the circuit being tested.

2. Disconnect circuit being tested from its power source. To be safe, disconnect the negative battery cables (page 2-24).
3. Connect multimeter probes to both terminals of circuit being tested. (See illustration.)

NOTE

All electrical circuits have a small amount of resistance. When testing a long cable, the needle may not quite reach the 0 point, even when the circuit is good.

4. Watch the multimeter needle for the following indications:
 - If needle swings to 0 on OHMS (Ω) scale, the circuit has continuity.
 - If needle stays at infinity (∞), circuit is open.
 - If needle jumps or flickers, there is a loose connection in the circuit being tested.

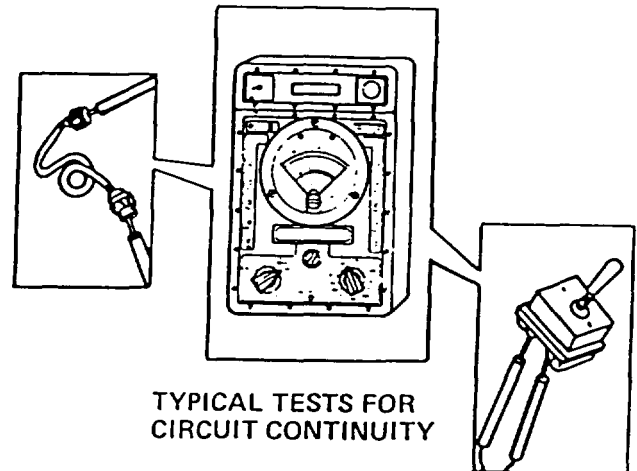

TESTING FOR SHORTS

A short (or short circuit) occurs when two circuits that should not be connected have come in contact with each other. A short also occurs when a circuit that should not touch ground has made contact with ground. Follow the instructions below to check for shorts in a circuit.

NOTE

The TS-352 B/U multimeter is shown in these instructions, but the procedures are similar for any of the multimeters.

1. Set and zero multimeter for OHMS RX100.

CAUTION

The multimeter can be damaged unless power is removed from the circuit being tested.

2. Disconnect circuit being tested from its power source. To be safe, check for voltage first (page 3-9).
3. Connect one multimeter probe to one circuit and the other probe to the other circuit, or ground (if checking for a short to ground). The example shows a check to see if wire A is shorted to wire B in a wiring harness.
4. Watch the multimeter needle (1) for the following indications:
 - If needle moves (even a little), circuits are shorted.
 - If needle does not move, set selector to X10K. If needle still does not move, circuits are not shorted.
 - If needle jumps or flickers, circuits are intermittently shorted. Bending or flexing a wiring harness, while checking for shorts, will often identify and locate intermittent shorts.

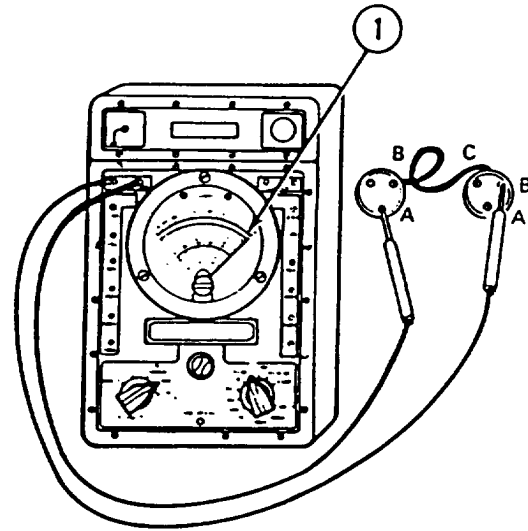

TYPICAL TEST FOR SHORTS

MEASURING RESISTANCE

1. Set and zero multimeter for OHMS RX1.

CAUTION
 The multimeter can be damaged unless power is removed from the circuit being tested.

2. Disconnect circuit being tested from its power source. To be safe, check for voltage first (page 3-9).

NOTE

Zero multimeter every time you change ranges.

3. If test calls for an ohms range different than RX1 (or X1), set selector switch to that range (such as RX10 or X10).
4. Connect probes to circuit or item to be measured.
5. Read multimeter scale. If it is set to RX1 or X1 range, take reading directly from OHMS(Ω) scale. multimeter is set to a different range, multiply reading on scale according to the table below.

OHMS SWITCH SETTING

X1 or RX1	Read number on scale
X10 or RX10	Multiply reading by 10
X100 or RX100	Multiply reading by 100
X1K or RX1K	Multiply reading by 1,000
X10K or RX10K	Multiply reading by 10,000
(REMEMBER: K=1,000)	

For example, the multimeters below indicate the following readings:

OHMS SWITCH SETTING

- X1 or RX1
- X10 or RX10

READING (OHMS)

- 4
- 40

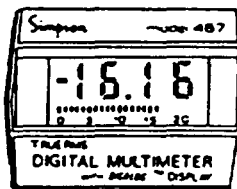

AN/PSM-45

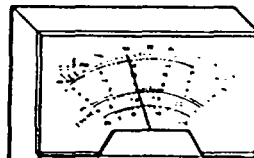

SIMPSON 160

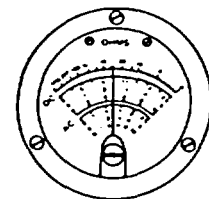

TS-352 B/U

USING THE DC VOLTS SCALE

SETTING THE METER

CAUTION

The multimeter must be set to a voltage range higher than that being measured or multimeter could be damaged.

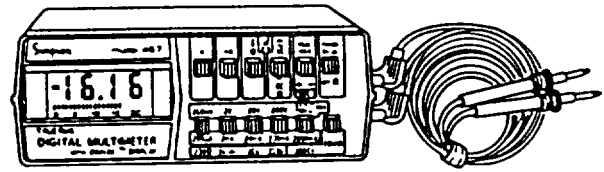

AN/PSM-45

AN/PSM-45

1. Connect red lead to V-OHMS jack.
2. Connect black lead to COM jack.
3. Set multimeter switches as specified in TM 11-6625-3052-14.
4. Depress appropriate voltage range switch. If voltage being measured is unknown, select 1000 V range.

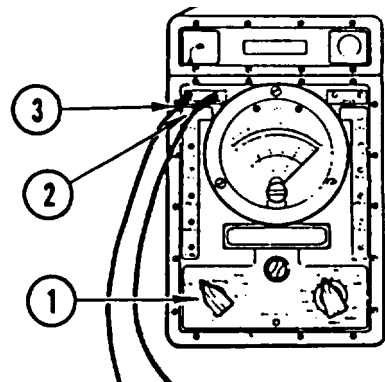

TS-352 B/U

1. Set FUNCTION switch (1) to DIRECT.
2. Plug black (-) lead (2) in -DC/±AC/OHMS jack.
3. To measure 24 volts DC, plug red lead (3) in 50 V jack on left side of multimeter. (If measuring less than 10 volts DC, use 10 V jack. If measuring less than 2.5 volts DC, use 2.5 V jack.)

SIMPSON 160

1. Plug black lead (1) in COM -jack.
2. Plug red lead (2) in +jack.
3. To measure 24 volts DC, set selector switch (3) to V/DC 50. (If measuring less than 10 volts DC, set selector switch to V/DC 10. If measuring less than 2.5 V/DC, set selector switch to V/DC 2.5.)
4. Set -DC/+DC switch (4) to +DC.

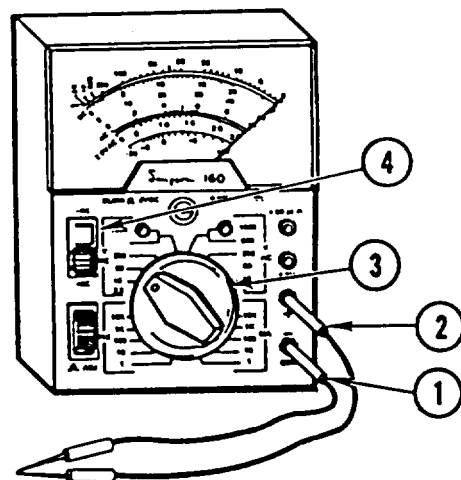

MEASURING DC VOLTAGE

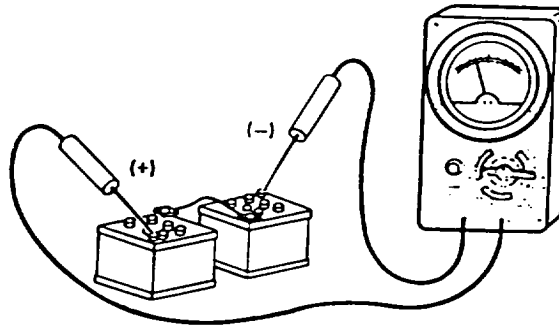

TYPICAL DC MEASUREMENT

1. Set multimeter to the correct scale. (See USING THE DC VOLTS SCALE, page 3-8).

CAUTION
 The multimeter must be set to a voltage range higher than that being measured or multimeter could be damaged.

2. Connect red probe to positive (+) side of circuit and black probe to negative (-) side. Example shows 24 volts DC being measured across batteries.
3. Read multimeter. (The following examples show how to read all three multimeters.) If needle moves off scale to left, reverse probes on circuit.

AN/PSM-45

Refer to TM 11-6625-3052-14 for proper use and explanations with the AN/PSM-45 multimeter.

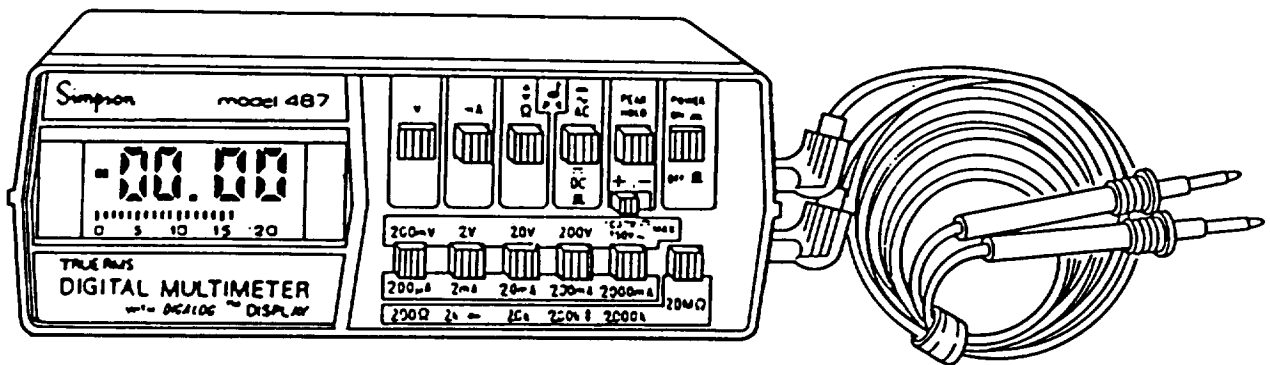

AN/PSM-45

MEASURING DC VOLTAGE (CONT)

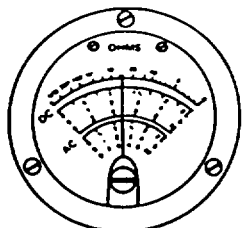

TS-352 B/U

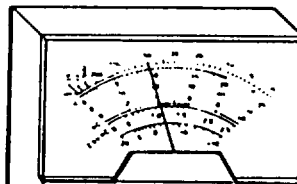

SIMPSON 160

TS-352 B/U

Read DC voltage scale for range in which red lead is plugged.

RANGE (VOLTS DC)		
50	0-5	(Multiply reading by 10)
10	0-10	(Read number on scale)
2.5	0-2.5	(Read number on scale)

The multimeter indicates the following readings:

RANGE (VOLTS DC)	READING (VOLTS DC)
50	20
10	4
2.5	1

SIMPSON 160

Read DC voltage scale for range at which selector switch is set.

SWITCH SETTING (VOLTS DC)		
50	0-50	(Read number on scale)
10	0-10	(Read number on scale)
2.5	0-25	(Divide reading by 10)

MEASURING DC VOLTAGE (CONT)

The multimeter indicates the following readings:

SWITCH SETTING (VOLTS DC)	READING (VOLTS DC)
50	20
10	4
2.5	1

NOTE

Proper operation of electrical components depends upon proper grounding. When troubleshooting devices that depend on screws or physical contact for their electrical ground (lamp sockets, transmitters, batteries, etc.), use a jumper wire from the device to the hull to check grounding.

Section II. WIRING HARNESS AND WIRE REPAIR

OVERVIEW

This section contains instructions for repair of wiring harnesses and wires (leads). Repair of wiring harnesses and wires consists of replacement of defective connectors, shells, and terminal, or taping cut or worn insulation and exposed wire conductors. Pages 3-12 thru 3-17 show exploded views of typical harness and wire connectors used on the vehicle, and give procedures for disassembly and assembly of connectors. When soldering is required, procedures in TB SIG 222 must be followed. If multiple pin connectors are disassembled, tag or label all wires to ensure correct connections are made at time of assembly.

The following procedures are contained in this section:

	Page
Typical Panel Mounting Receptacle: Disassembly and Assembly	3-12
Typical Plug: Disassembly and Assembly	3-13
Wire Terminals and Connectors Replacement	3-14
Terminal-Type Wire Connector.	3-14
Male Wire Connector	3-14
Female Wire Connector (with Washer)	3-15
Female Wire Connector (with Sleeve)	3-15
Threaded Plug Connector	3-16
Typical Plug Connector	3-17

TYPICAL PANEL MOUNTING RECEPTACLE: DISASSEMBLY AND ASSEMBLY

DISASSEMBLY

1. Unscrew nut from shell assembly and slide back on wire leads.
2. Push grommet back on wire leads.
3. Drive contacts out through rear of insert with pin extractor.
4. Push insert out through rear of shell.
5. Unsolder wire leads from contacts.

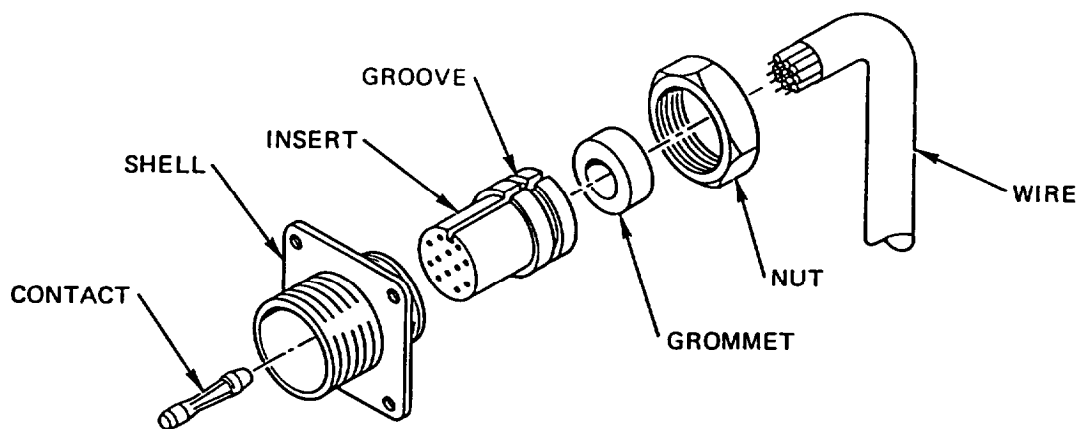

ASSEMBLY

1. Strip cable insulation equal to depth of solder wells of contacts.
2. Slide nut over wire leads.
3. Slide grommet over wire leads.
4. Insert wire leads into solder wells of contacts, and solder.
5. Push insert into shell from rear until seated. Groove in insert must be aligned with guide in shell to ensure proper fit.
6. Push contacts into insert from rear until seated.
7. Push grommet down wire leads and over solder wells of contacts.
8. Screw nut onto shell assembly.

TYPICAL PLUG: DISASSEMBLY AND ASSEMBLY

DISASSEMBLY

1. Unscrew nut from shell assembly and slide back on wire leads.
2. Slide grommet back on wire leads.
3. Slide coupling nut off shell assembly.
4. Drive contacts out through rear of insert with pin extractor.
5. Push insert out through rear of shell.
6. Unsolder wire leads from contacts.

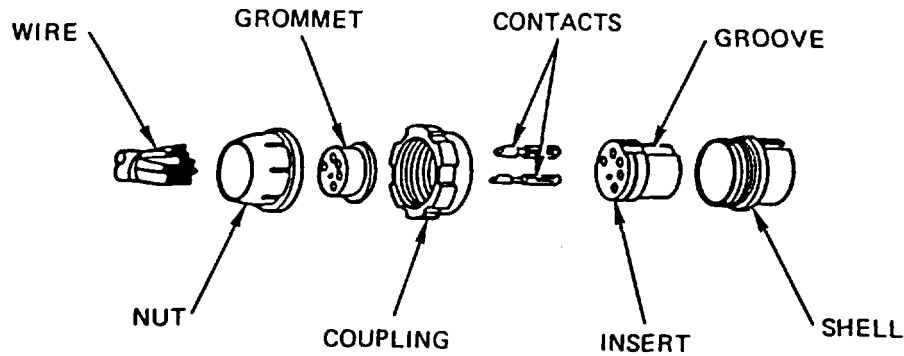

ASSEMBLY

1. Strip wire insulation equal to depth of solder wells of contacts.
2. Slide nut over wire leads.
3. Slide grommet over wire leads.
4. Insert wire leads into solder wells of contacts, and solder.
5. Push insert into shell from rear until seated. Groove in insert must be aligned with guide in shell to ensure proper fit.
6. Push contacts into insert from rear until seated.
7. Slide coupling nut onto shell assembly.
8. Push grommet down wire leads and over solder wells of contacts.
9. Screw nut onto shell assembly.

WIRE TERMINALS AND CONNECTORS REPLACEMENT

TERMINAL-TYPE WIRE CONNECTOR

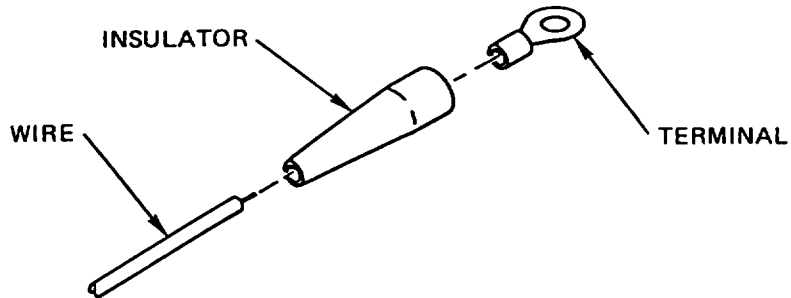

1. Strip wire insulation equal to depth of terminal well.
2. Slide insulator over wire.
3. Insert wire into terminal well, and crimp.
4. Slide insulator over crimped end of terminal.

MALE WIRE CONNECTOR

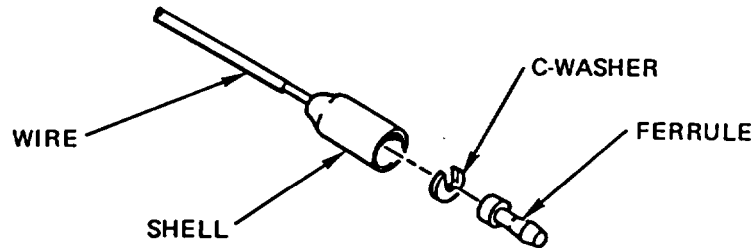

1. Strip wire insulation equal to depth of ferrule well.
2. Slide shell over wire.
3. Insert wire into terminal well, and crimp.
4. Place C-washer over wire at crimped junction and slide shell over C-washer and terminal.

WIRE TERMINALS AND CONNECTORS REPLACEMENT (CONT)

FEMALE WIRE CONNECTOR (WITH WASHER)

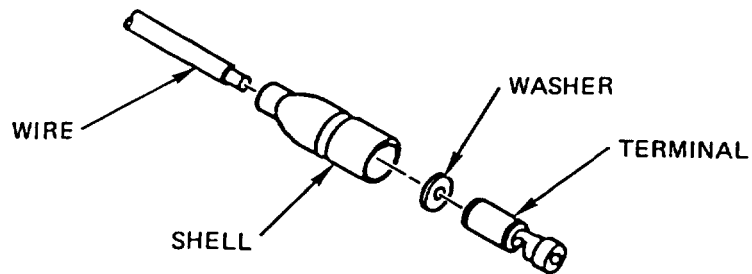

1. Strip wire insulation approximately 1/8 in. (3 mm).
2. Slide shell and washer over wire.
3. Place wire in cylindrical end of terminal, and crimp.
4. Slide shell and washer over terminal.

FEMALE WIRE CONNECTOR (WITH SLEEVE)

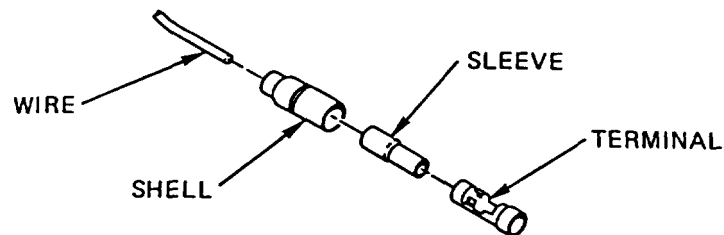

1. Strip wire insulation approximately 1/8 in. (3 mm).
2. Slide shell and sleeve over wire.
3. Place wire in cylindrical end of terminal, and crimp.
4. Slide shell and sleeve over terminal.

WIRE TERMINALS AND CONNECTORS REPLACEMENT (CONT)

THREADED PLUG

DISASSEMBLY

1. Pull receptacle off body and slide back on wires.
2. Push wires out of body and remove connectors from wires.
3. Remove body, spacer, nut, and receptacle from wires.

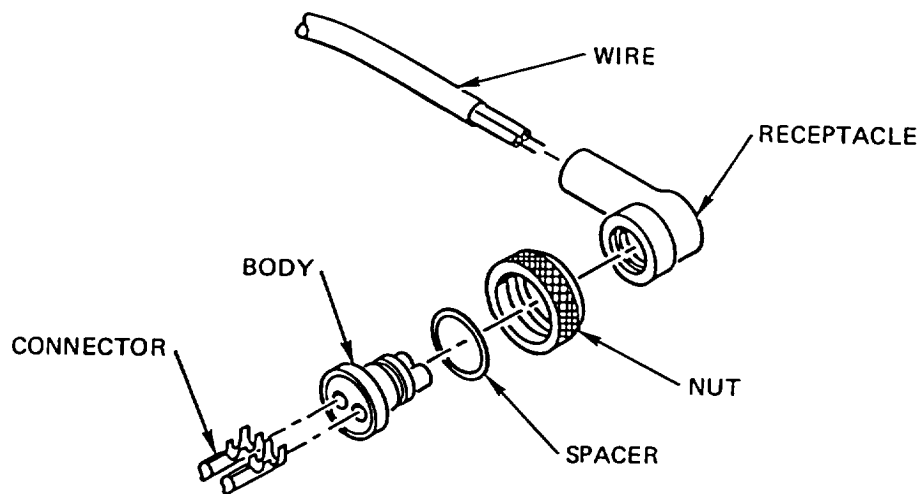

ASSEMBLY

1. Strip wire insulation approximately 1/8 in. (3 mm).
2. Slide receptacle, nut, spacer, and body over wires.
3. Install connectors on wires and insert into body.
4. Slide receptacle onto body.

WIRE TERMINALS AND CONNECTORS REPLACEMENT (CONT)

TYPICAL PLUG CONNECTOR

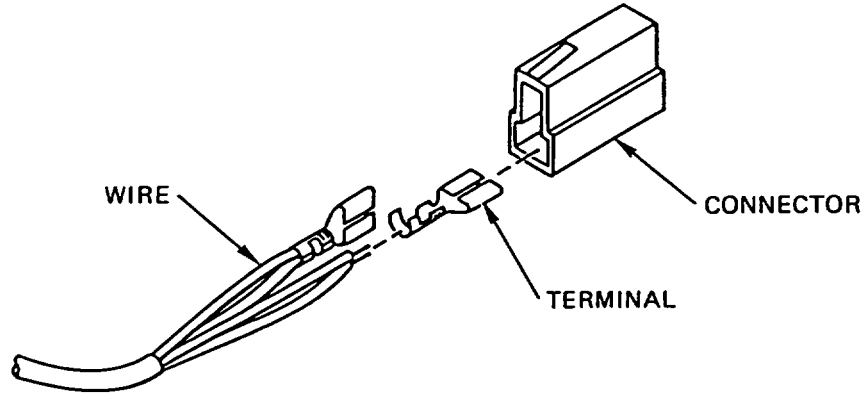

1. Strip wire insulation approximately 1/8 in. (3 mm).
2. Crimp terminal onto wire.
3. Insert terminal into connector.

Section III. USING STE/ICE-R WITH THE TRACTOR

OVERVIEW

This section contains information on the use of Simplified Test Equipment for Internal Combustion Engines Re-Programmable (STE/ICE-R) with the SEE/HMMH. Two types of testing are performed: Go and No-Go. Refer to the STE/ICE Technical Manual (TM 9-4910-571-12&P) when using STE/ICE-R.

The following are contained in this section:

	Page
Pretest Inspection	3-17
Test Hookup	3-18
Confidence Test	3-18
Testing	3-18

PRETEST INSPECTION

The daily preventive maintenance inspections and procedures must be performed on the SEE/HMMH before performing STE/ICE-R tests.

TEST HOOKUP

Connect the vehicle test meter (VTM) to the vehicle diagnostic connection assembly (DCA) with DCA cable W1.

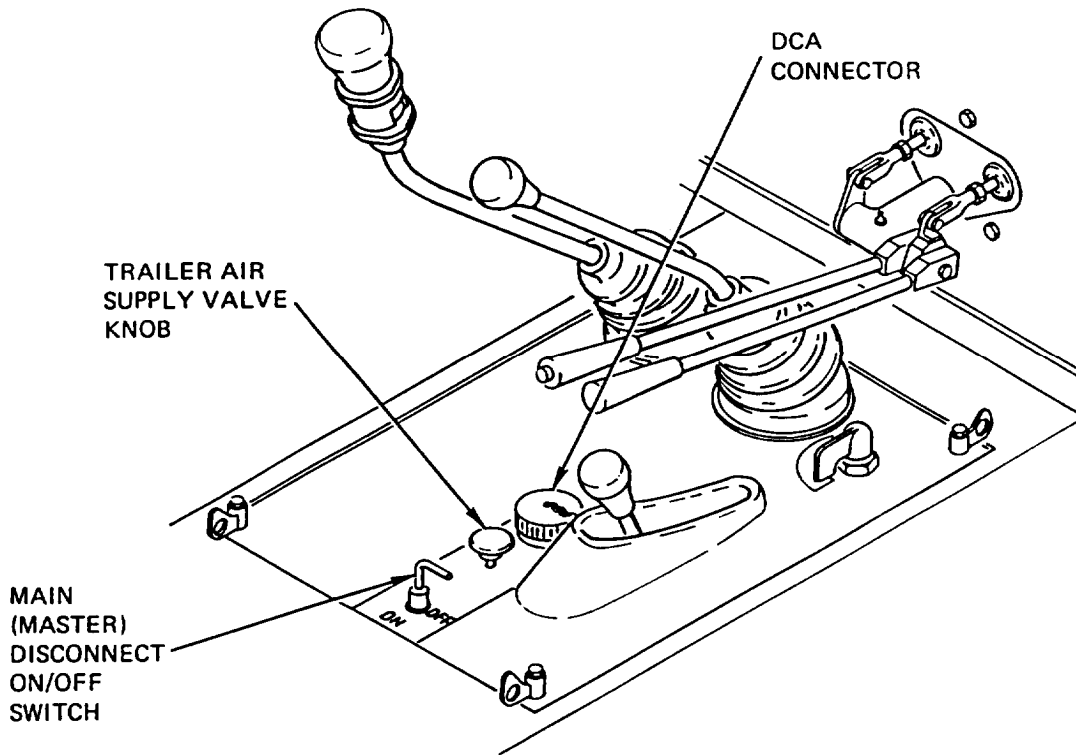

Location of DCA Connector in Cab

CONFIDENCE TEST

Perform the confidence test as described in the STE/ICE Technical Manual (TM 9-4910-571-12&P).

STE/ICE-R vehicle test cards are provided for the tests to be performed on the SEE/HMMH. Complete test procedures and accepted standards are contained in these cards. The various tests are described in table 3-1. Typical STE/ICE-R error messages are described in table 3-2. Table 3-3 describes typical operator messages and actions to be taken. Table 3-4 lists the tractor test parameters and vehicle status during the test.

Table 3-1. STE/ICE-R Tests

Test Select No.	Test	
CONTROL FUNCTIONS		
01	Control	Interweaves (alternates rpm with next test measurement).
02	Control	Displays minimum value detected for next test.
03	Control	Displays maximum value detected for next test.
04	Control	Displays peak-to-peak value for next test.
06	Control	Interweaves two tests.
ENGINE TESTS		
10	ENGINE RPM	Measures average speed of engine crankshaft by means of pulse tachometer.
12	POWER TEST (RPM/SEC)	Measures engine's power producing potential in units of rpm/second.
14	COMPRESSION UNBALANCE	Evaluates relative cylinder compression and displays percentage difference between highest and lowest values in one engine cycle.
FUEL SYSTEM TESTS		
24 ¹ *	FUEL SUPPLY PRESSURE	Measures fuel pump outlet pressure.
26	FUEL FILTER PRESSURE DROP	Detects clogging by opening a differential pressure switch across secondary fuel filter.
STARTING/CHARGING SYSTEMS TESTS		
67	BATTERY VOLTAGE	Measures battery voltage at or near battery terminals.
68	STARTER MOTOR VOLTAGE	Measures voltage present at starter motor positive terminal.
69	STARTER NEGATIVE CABLE VOLTAGE DROP	Measures voltage drop on starter ground path. High voltage drop indicates ground path resistance.
70	STARTER SOLENOID VOLTAGE	Measures voltage present at starter solenoid positive terminal. Measures current through battery ground path shunt.
71*	STARTER CURRENT AVERAGE	Measures average current to or from starter.
72*	STARTER CURRENT FIRST PEAK	Tests condition of starting circuit and ability of starter to deliver sufficient starting current.
73*	BATTERY INTERNAL RESISTANCE	Evaluates battery condition by measuring voltage and current simultaneously.
74*	STARTER CIRCUIT RESISTANCE	Measures combined starter circuit and battery internal resistance.
75*	BATTERY INTERNAL RESISTANCE CHANGE	Measures rate of change of battery resistance to provide indication of battery condition.

Table 3-1. STE/ICE-R Tests (Cont)

Test Select No.	Test	
82	ALTERNATOR OUTPUT VOLTAGE	Measures alternator output voltage.
84	ALTERNATOR NEGATIVE CABLE VOLTAGE DROP	Measures voltage drop in alternator ground cable and connection between alternator ground connection and battery negative terminal. High voltage drop indicates excessive ground path resistance.

* Offset Test required.

¹If fuel pressure transducer is not installed on engine, remove 1/4-in. pipe plug and install pressure transducer TK item 17. Then perform test TK 50 to determine fuel supply pressure.

Table 3-2. Error Messages

Display	Message
E000	Information not available
E001	Test nonexistent
E002	Transducer not connected
E003	Information not valid in DCA mode
E004	Vehicle Identification Data (VID) or number of cylinders not entered
E005	Offset not performed
E007	Number of cylinders conflicts with VID
E008	Test probe not connected
E009	Engine not running
E010	Bad VID
E011	Acceleration/deceleration time too long
E012	Tachometer pickup missing
E013	Bad data
E014	Wrong number of cylinders
E015	No longer used, turn in VTM to maintenance
E017	No ignition information received (SI)
E018	Test discontinued, excessive time
E020	First peak information not received
E021	Result not calculated, current is over range
E022	External voltage detected
E023	VTM internal power supply defective
E024	Test not applicable
E027	Compression unbalance constants error
E028	Can't use this test with control function 06
E030	Speed transducer doesn't agree with VID
E032	Cranking RPM varies too much
E033	Power test constants entry error
.9.9.9.9	Overload number exceeds display capability

Table 3-3. Operator Messages

Display	Message
PASS	Test successfully completed
CAL	Offset test in progress, release test button
CIP	Initiate CI power simulation
CYL	Enter number of cylinders or cylinder pairs
FAIL	Test failed
GO	Crank engine
OFF	If cranking, STOP! If CI power, DECELERATE!
UEH	Enter vehicle identification number
—	VTM accepting data or initial turn-on

Table 3-4. Test Parameters

Test No.	Test	Operating Conditions	Min.	Norm	Max.	Units
10	ENGINE RPM	Engine at idle	700	—	750	rpm
12	POWER TEST	Engine running	2700	—	2900	rpm/sec
14	COMPRESSION UNBALANCE	Cranking	100	—	187	%
24*	FUEL SUPPLY PRESSURE	Cranking	15	—	40	psi
26	FUEL FILTER PRESSURE DROP	Engine running	—	PASS	—	—
67	BATTERY VOLTAGE	Engine stopped	23.5	—	—	volts
67	BATTERY VOLTAGE	Lights on, engine at idle	24.5	25.0	28.0	volts
68	STARTER MOTOR VOLTAGE	Cranking	19.0	—	—	volts
69	STARTER NEGATIVE CABLE VOLTAGE DROP	Cranking	—	—	0.8	volt
70	STARTER SOLENOID VOLTAGE	Cranking	18.0	—	—	volts
71	STARTER CURRENT AVERAGE	Cranking	—	200	—	amps
72*	STARTER CURRENT FIRST PEAK	Cranking	730	—	890	amps
73	BATTERY INTERNAL RESISTANCE	Cranking	—	—	25	milliohms
74	STARTER CIRCUIT RESISTANCE	Cranking	—	—	23	milliohms
75	BATTERY INTERNAL RESISTANCE CHANGE	Cranking	—	—	50.0	milliohms
82	ALTERNATOR OUTPUT VOLTAGE	Lights on, engine at idle	24.8	25.5	28.5	volts
84	ALTERNATOR NEGATIVE CABLE VOLTAGE DROP	Engine at idle	—	—	0.15	volt
84	ALTERNATOR NEGATIVE CABLE VOLTAGE DROP	Engine speed 1000-1200 rpm	—	—	0.30	volt

* If fuel pressure transducer is not installed on engine, remove 1/4-in. pipe plug and install pressure transducer TK item 17. Then perform test TK 50 to determine fuel supply pressure.

STE/ICE-R CI ENGINE GO-NO GO CHAIN

Run the STE/ICE-R Engine GO-NO GO Chain when called for in Table 3-5, Troubleshooting (page 3-70). Refer to STE/ICE-R Diagnostic Connector Assembly (DCA) Location (page 3-18) and TM 9-4910-571-12&P for setup and interpretation of test results.

Perform all Go (G) steps listed until a No-Go (NG) condition exists; then perform the NG steps indicated. Complete all repair or replacement tasks specified, using the List of Tasks (page iii) or Alphabetical Index (Index-1). Notify direct support maintenance if the condition persists.

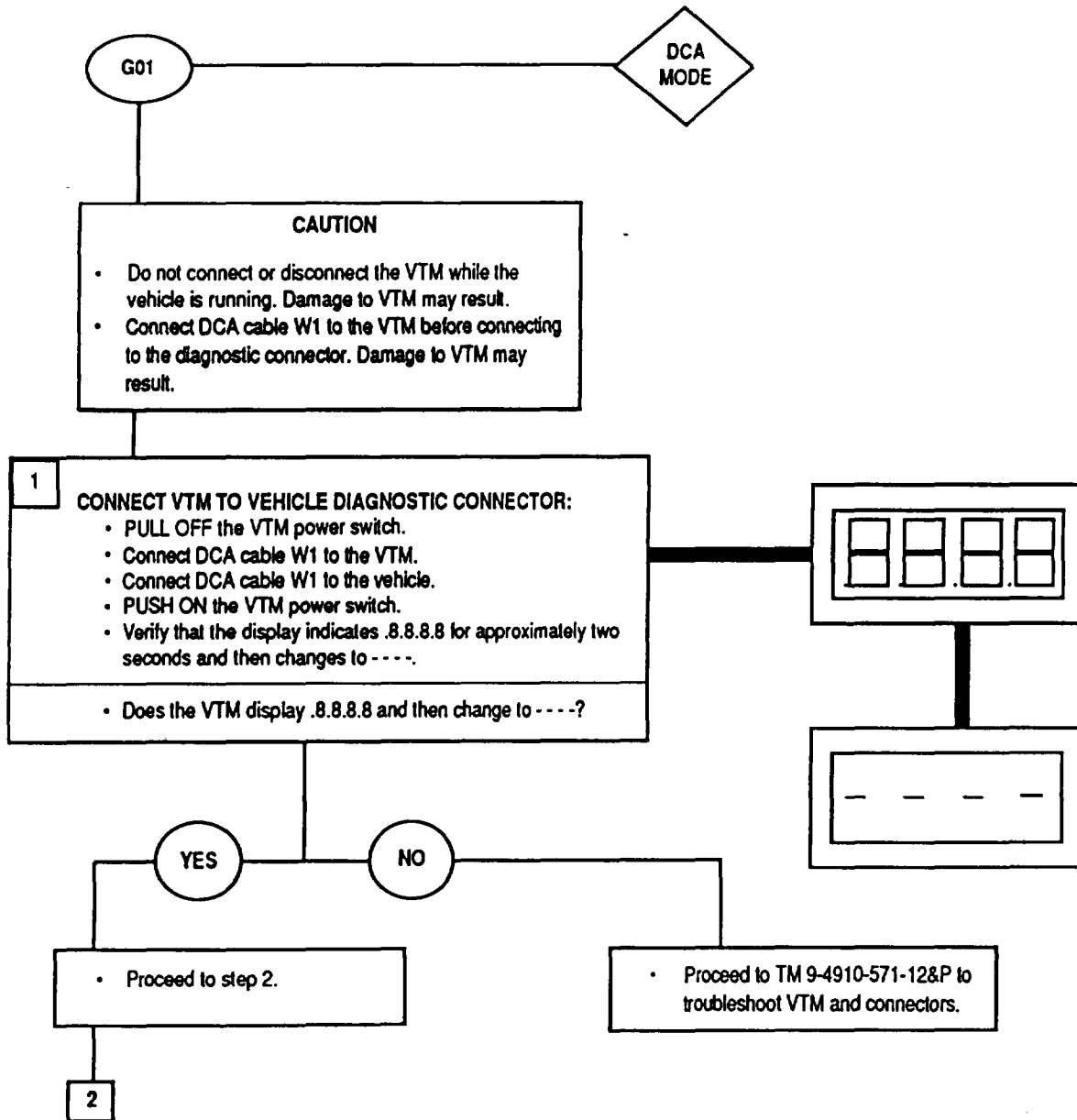

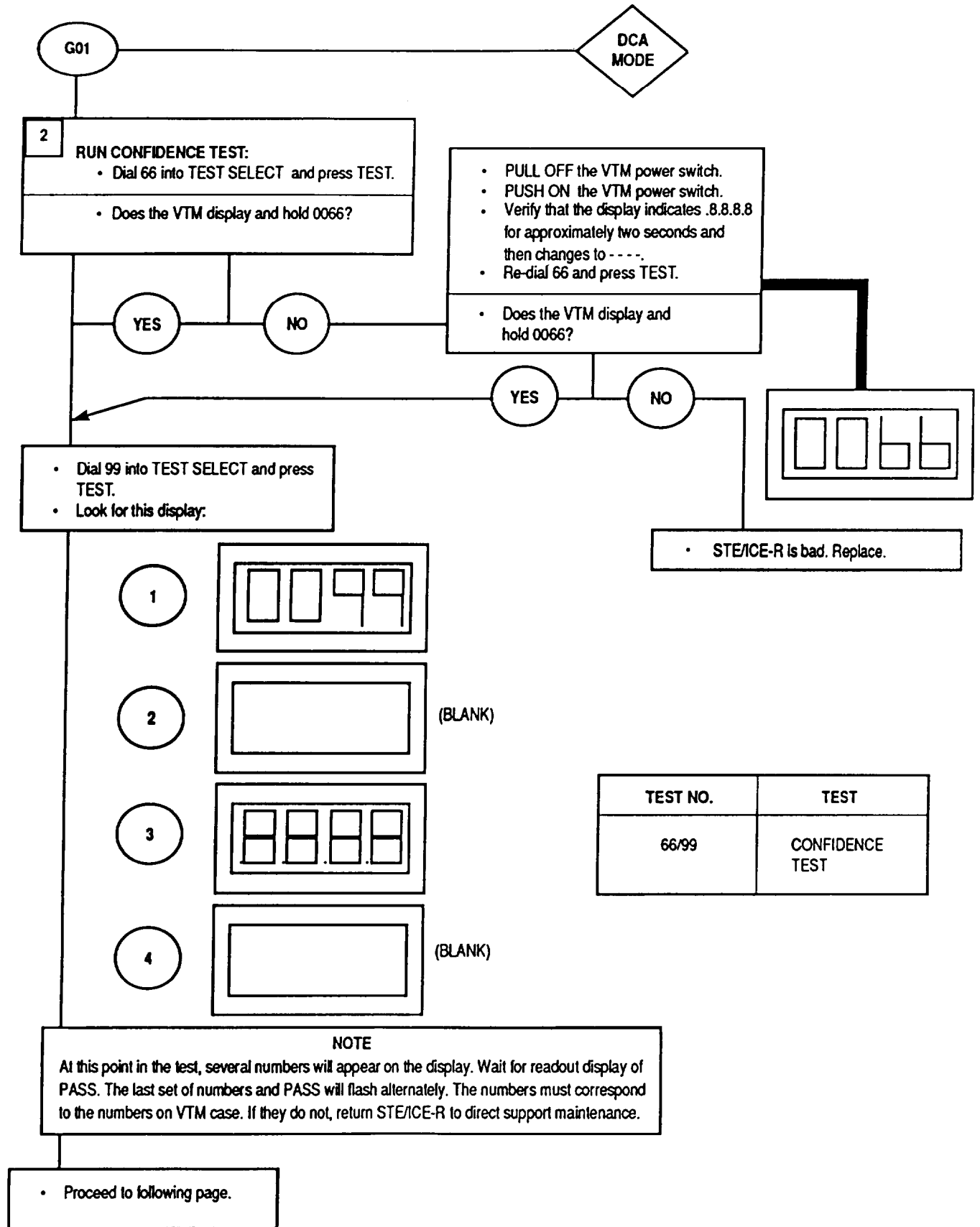

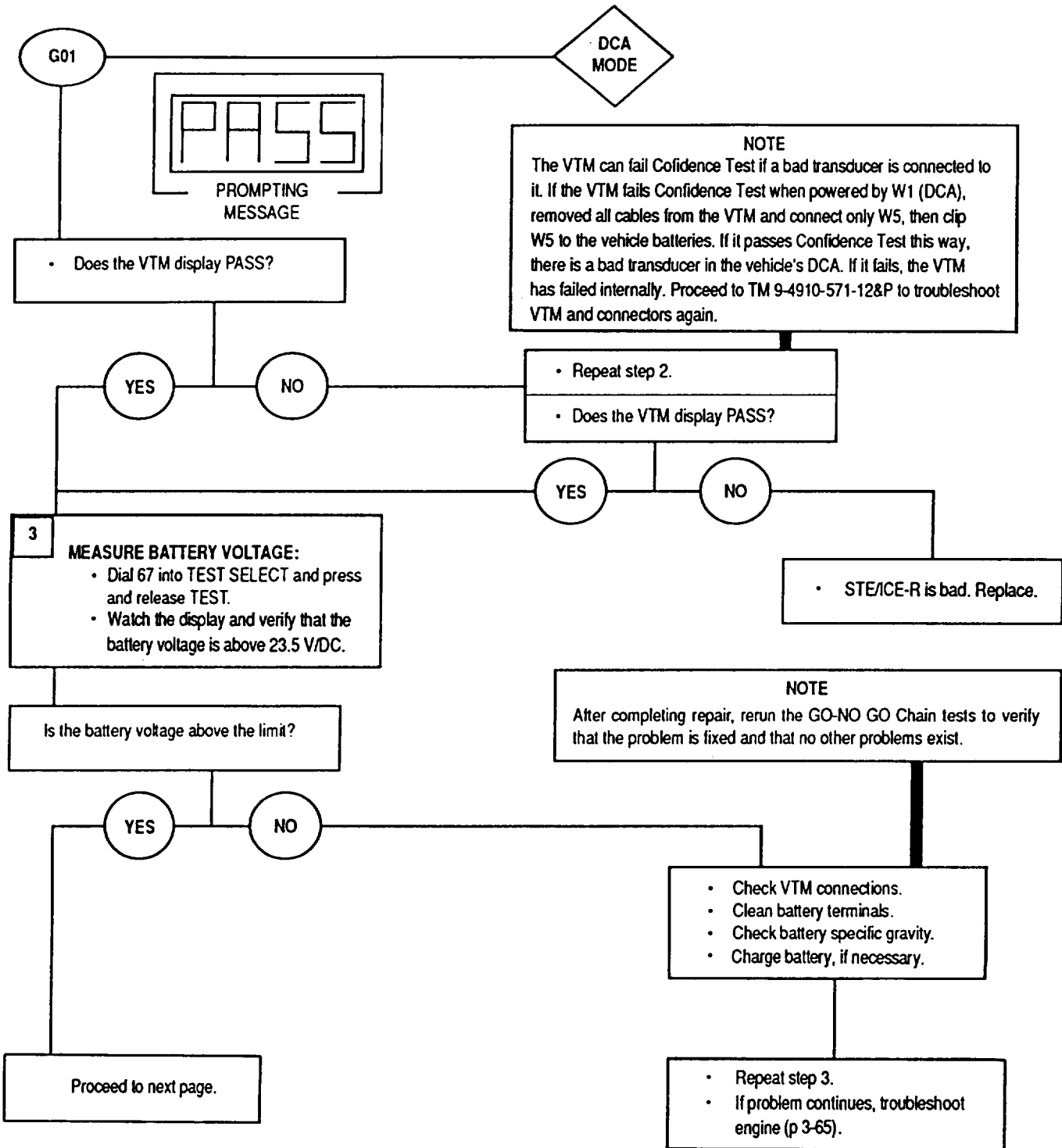

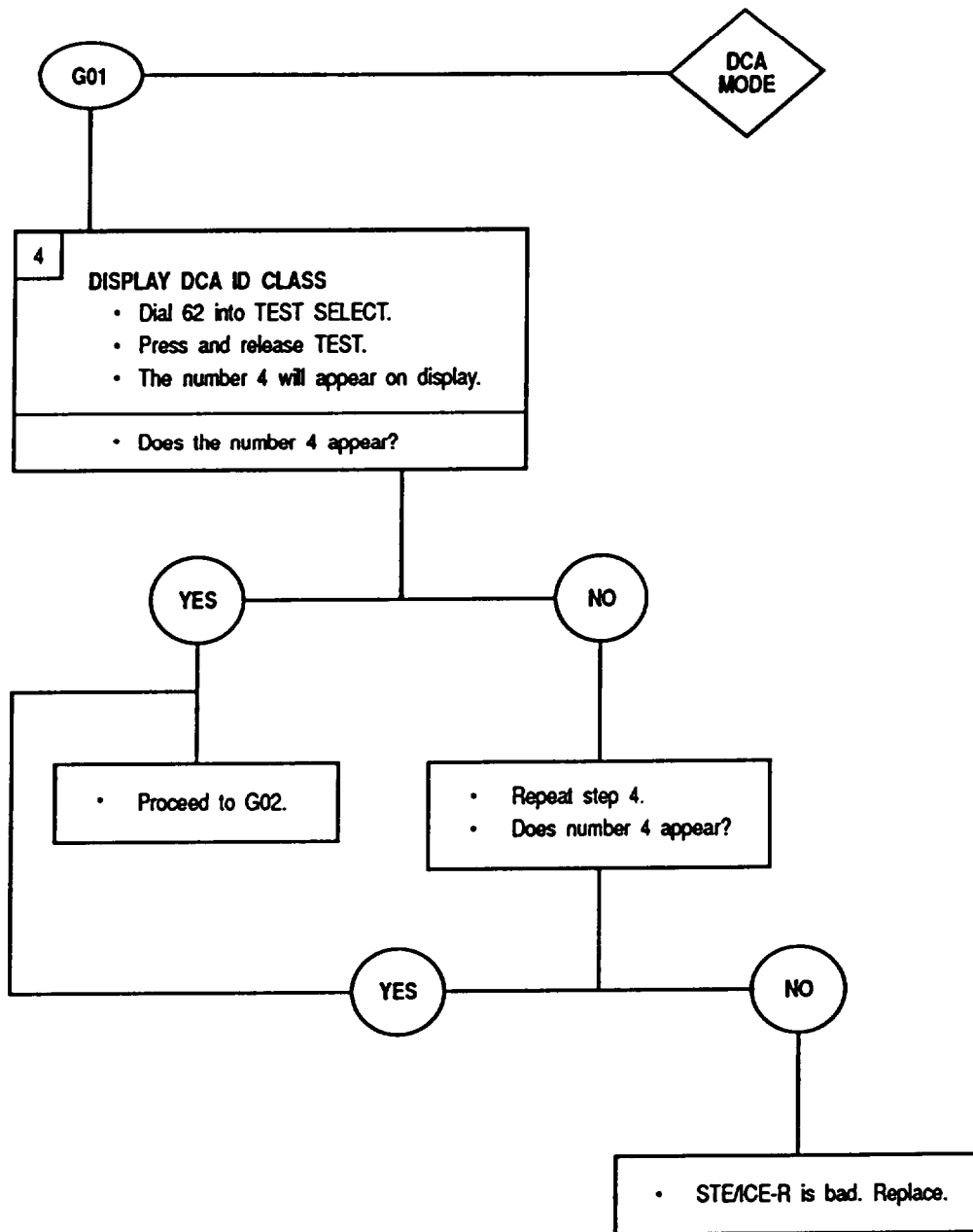

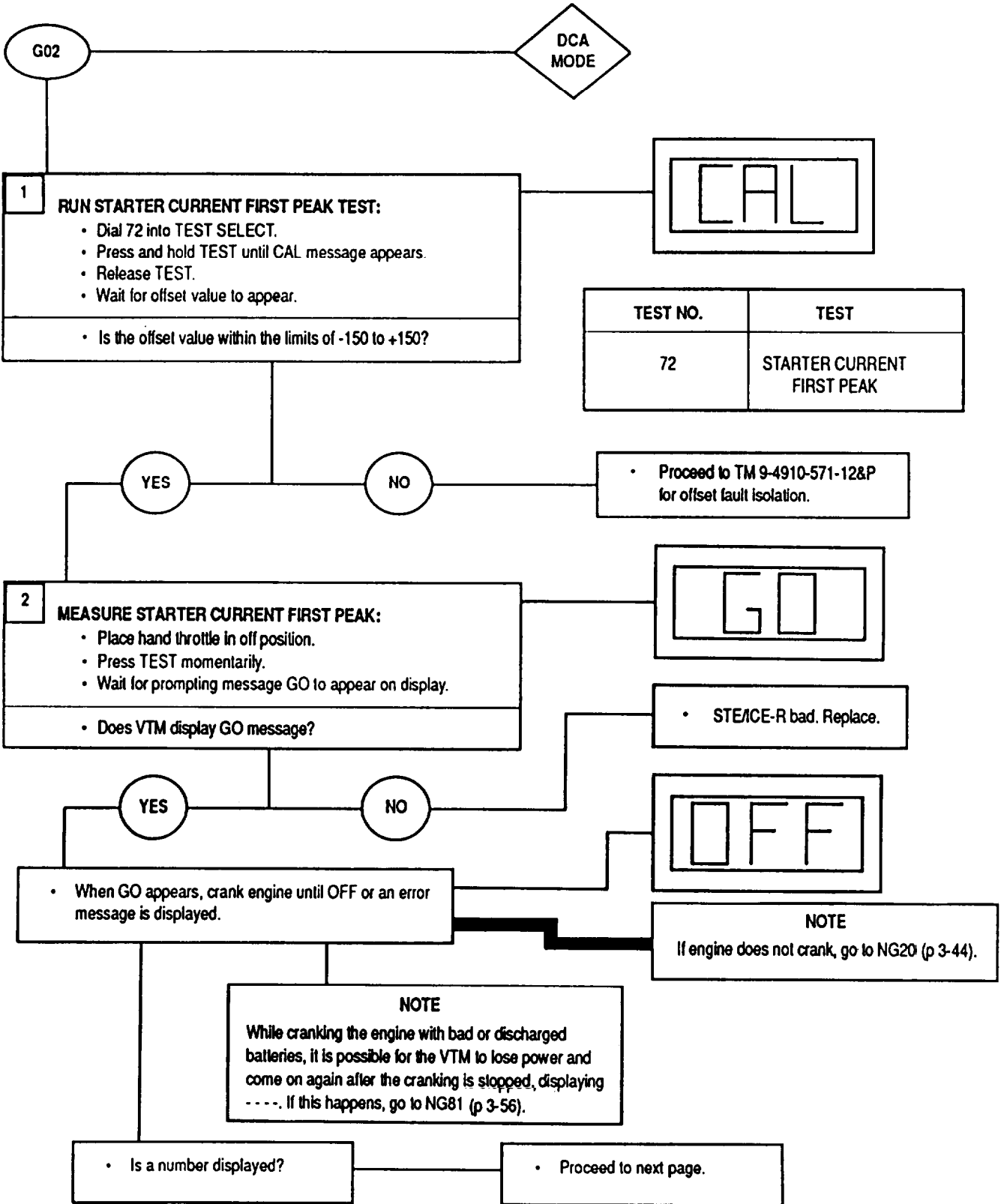

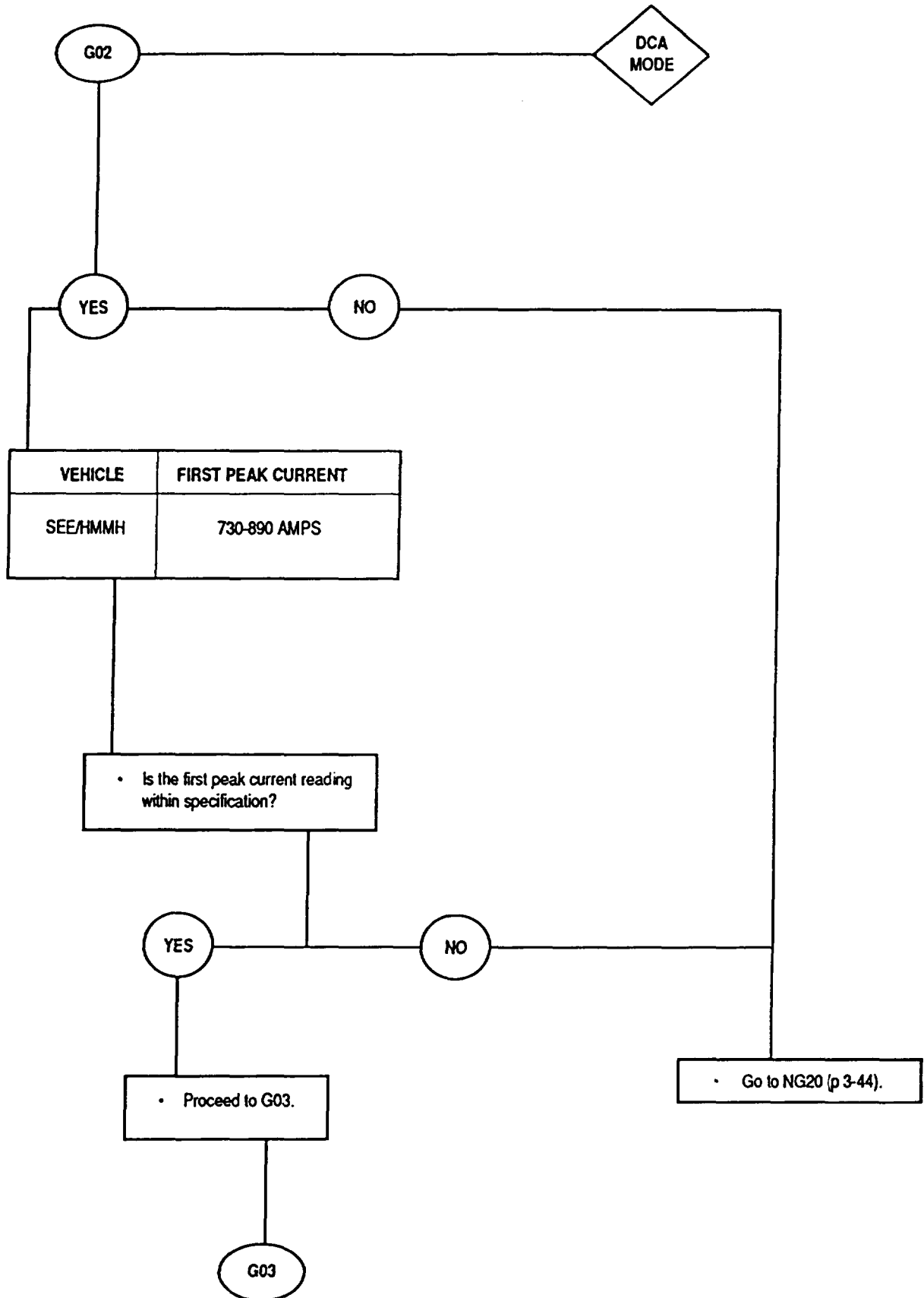

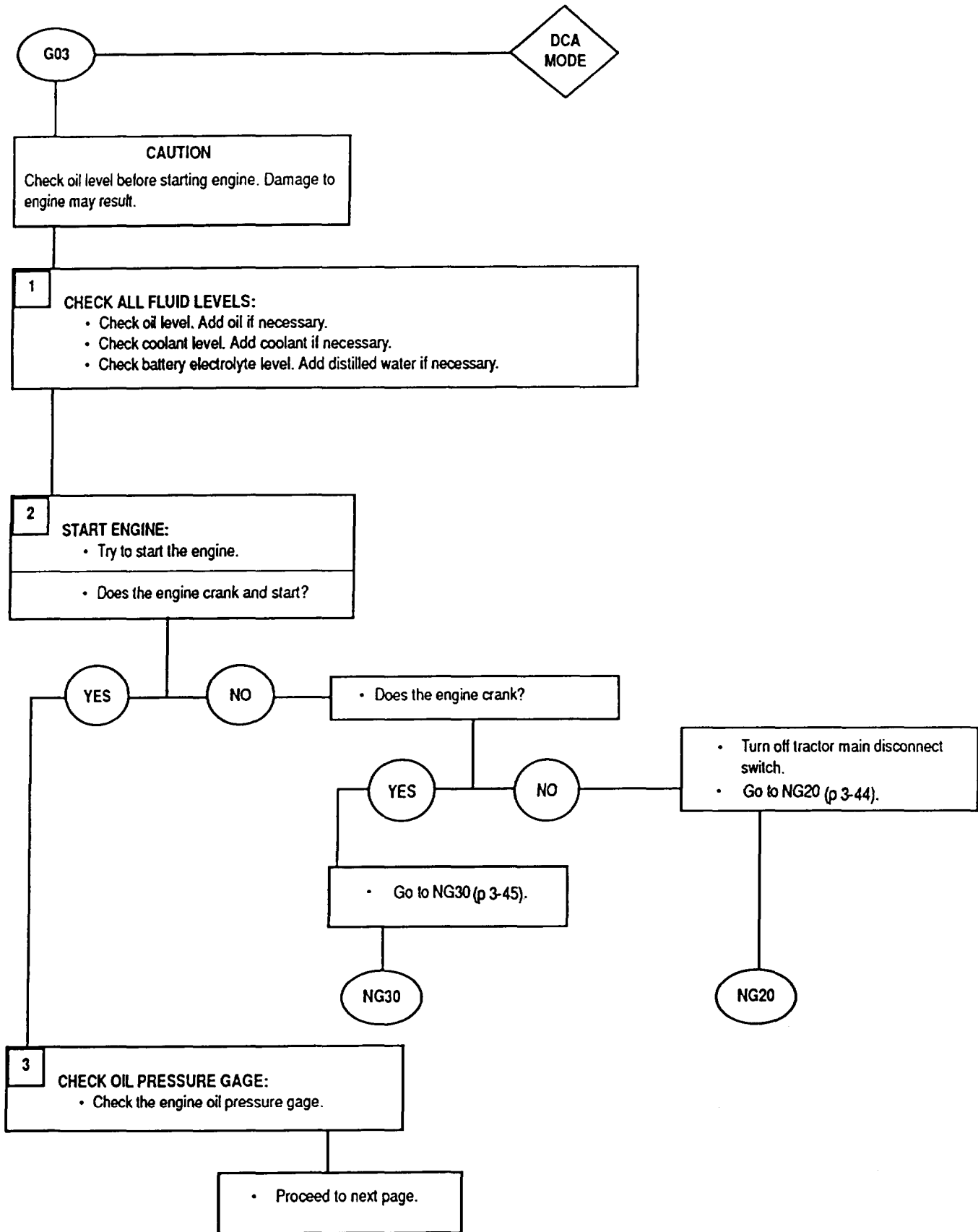

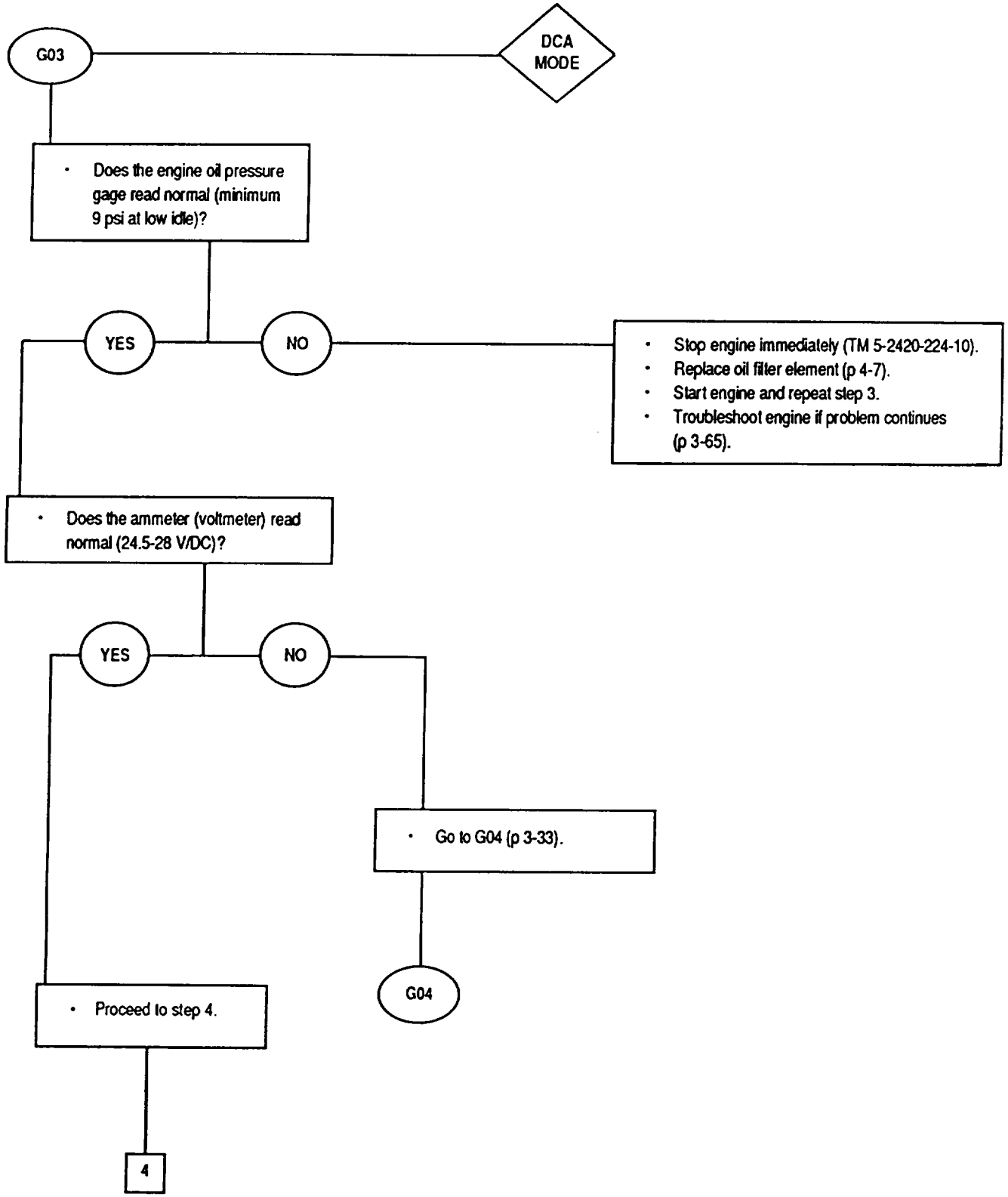

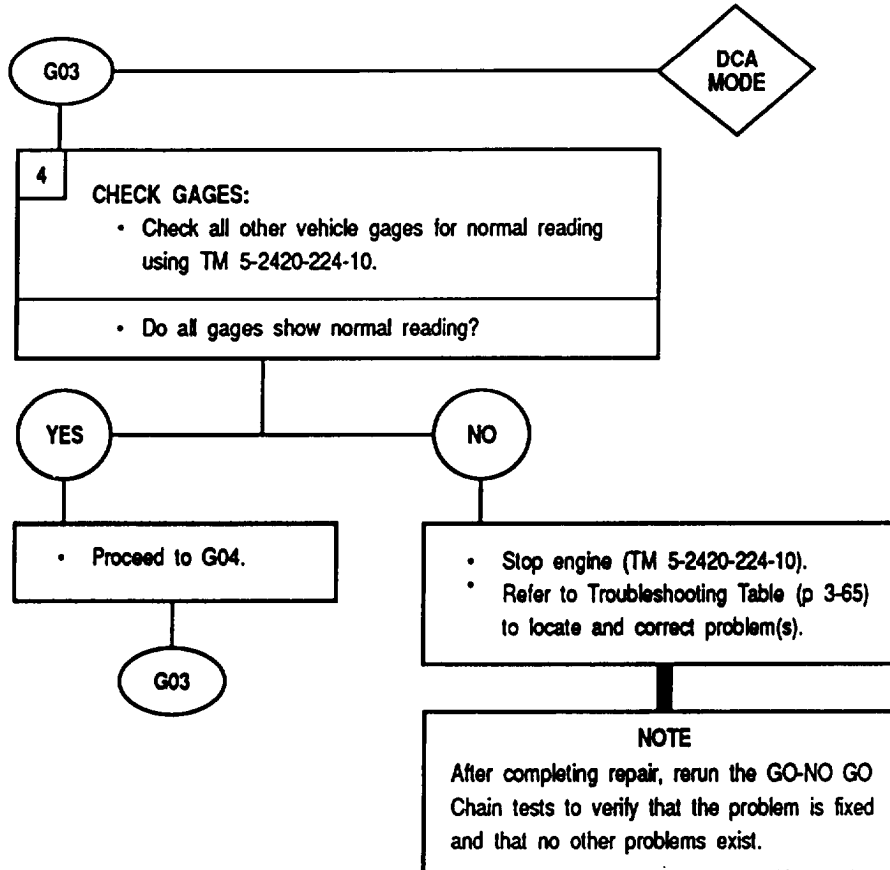

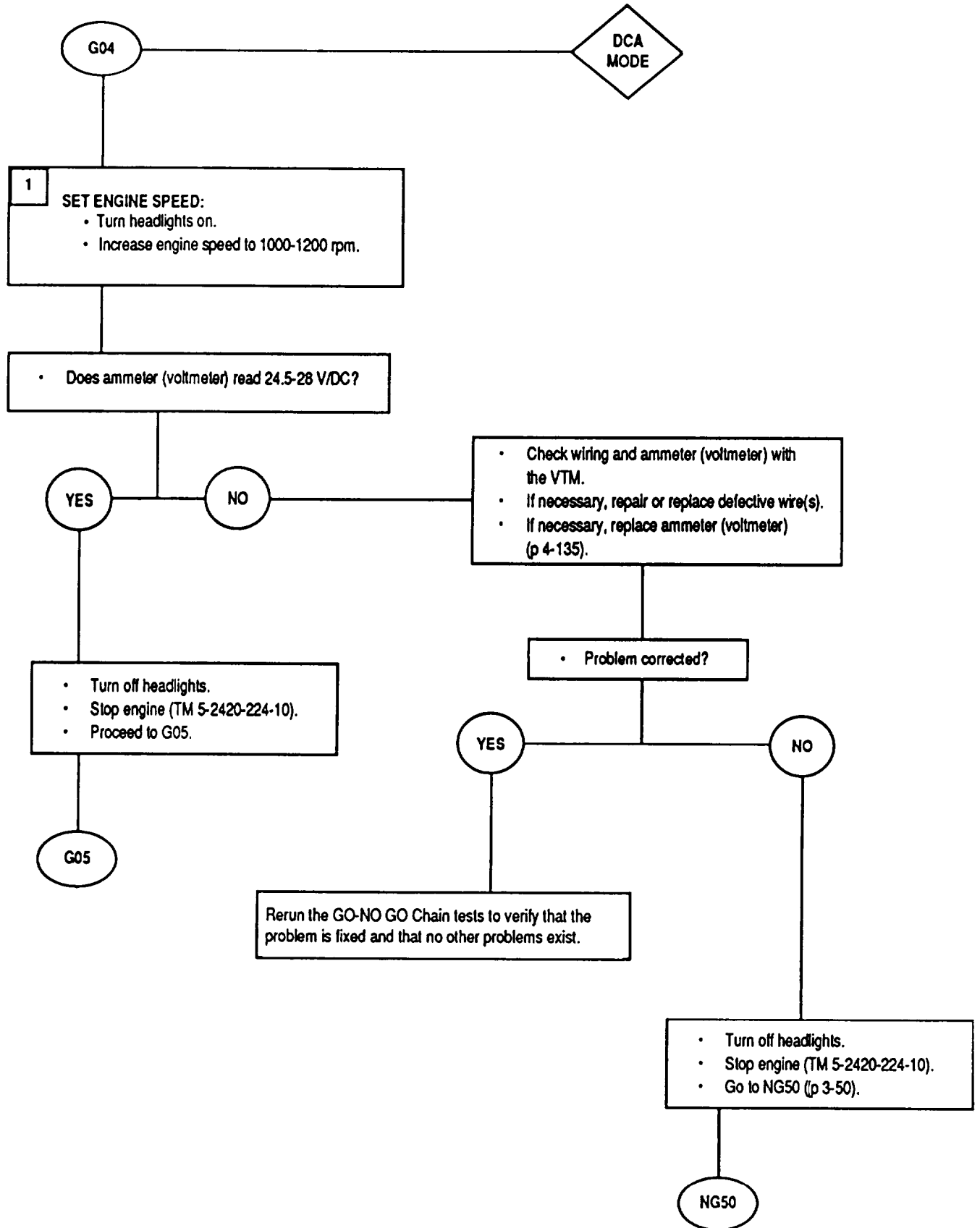

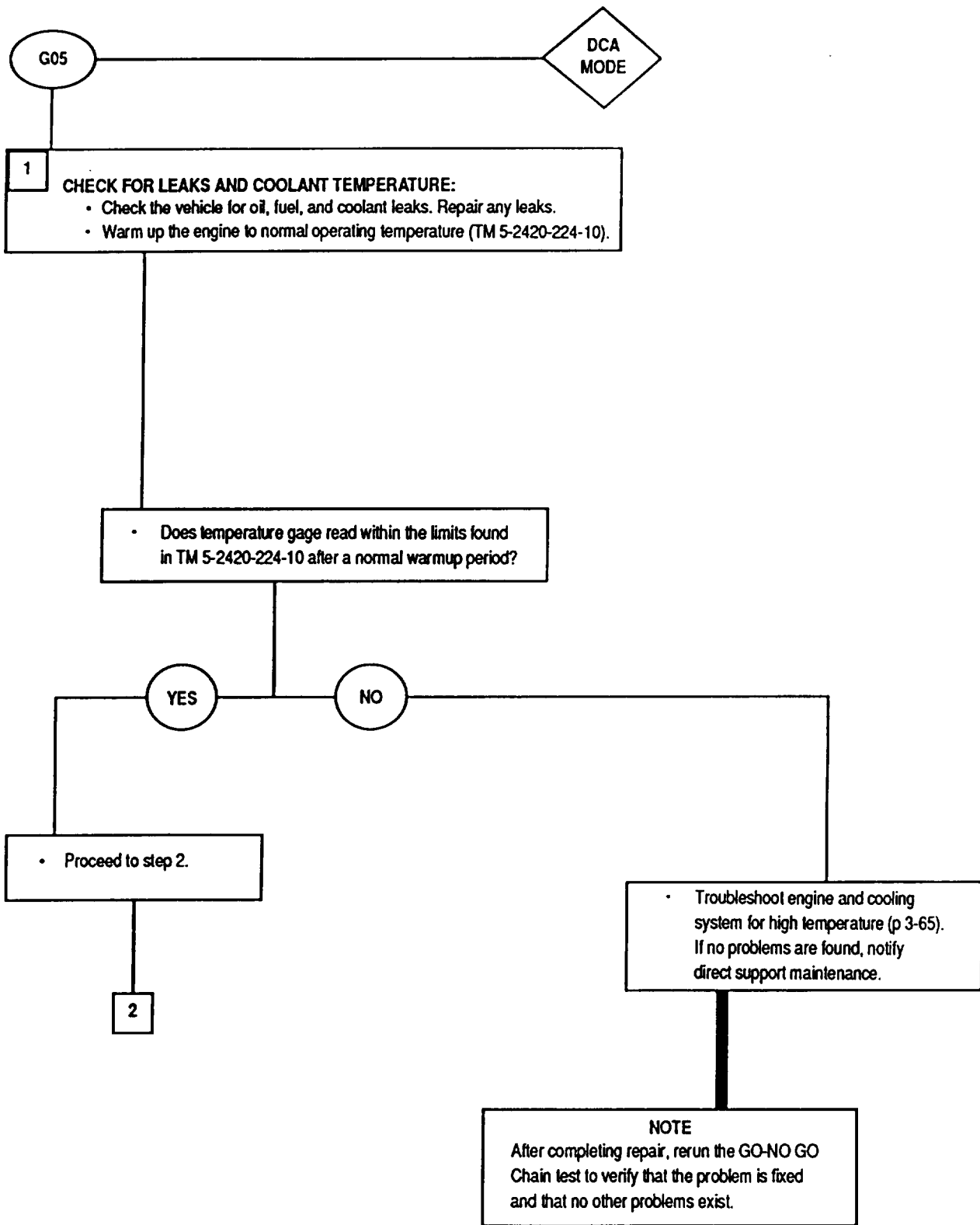

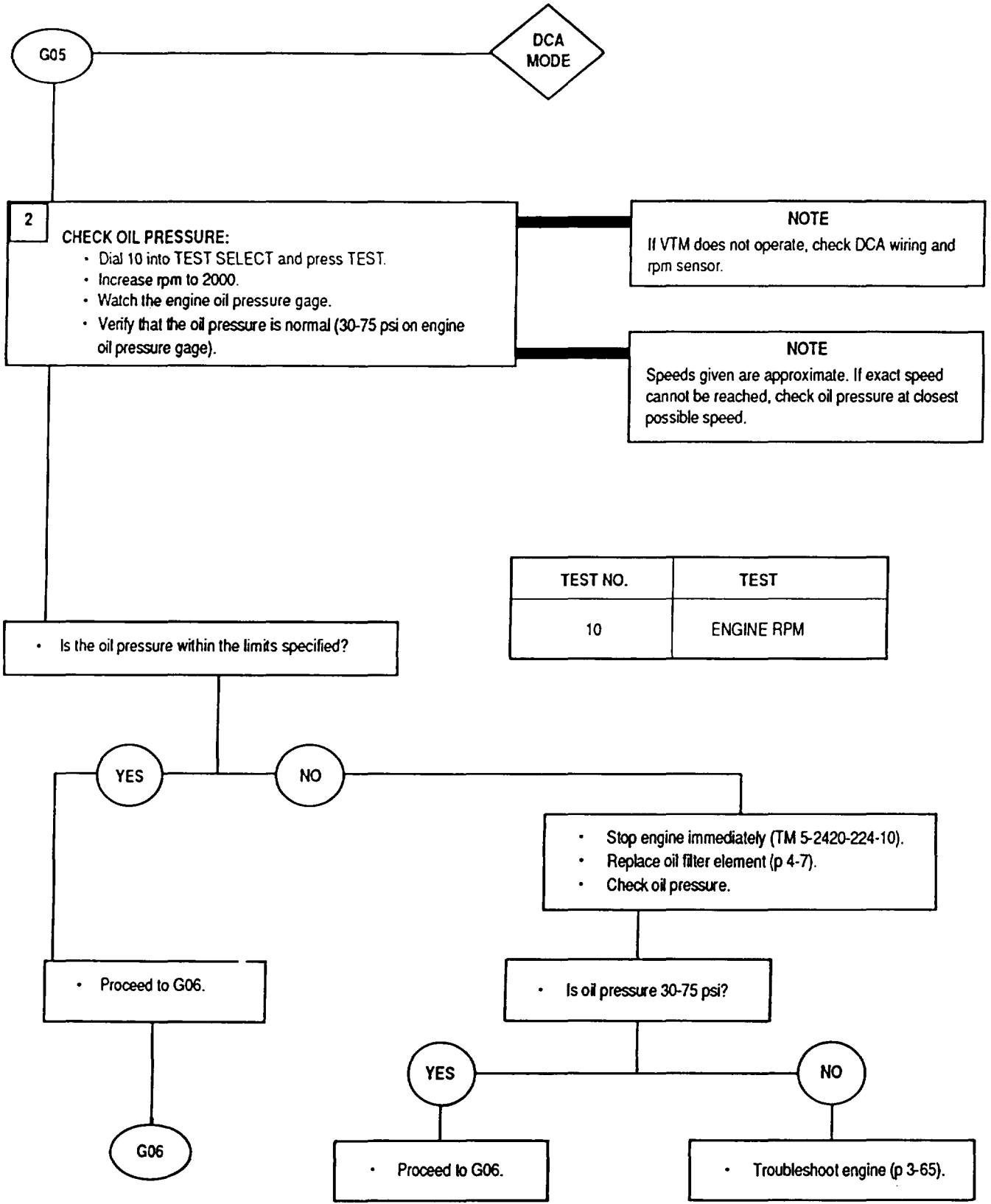

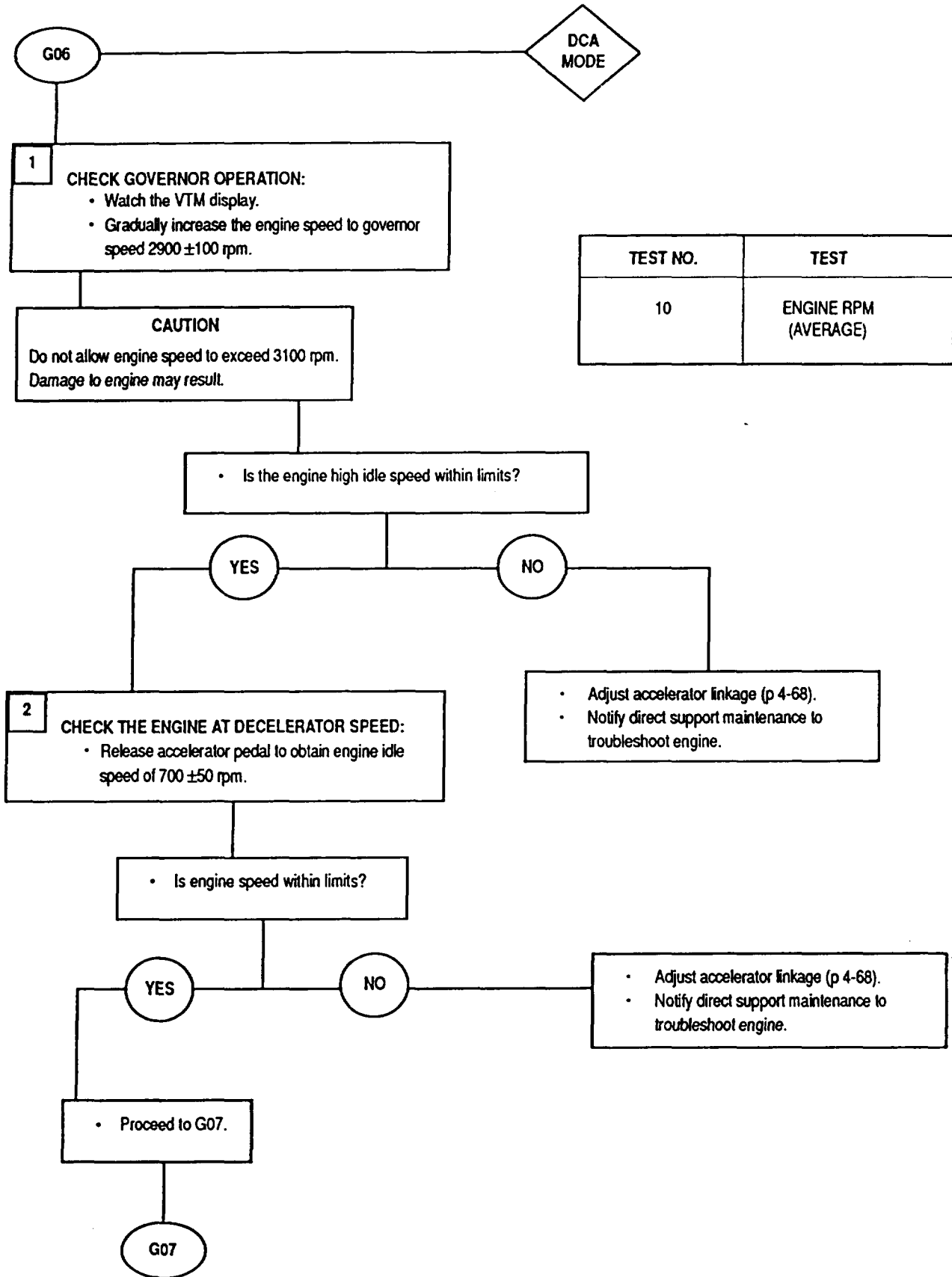

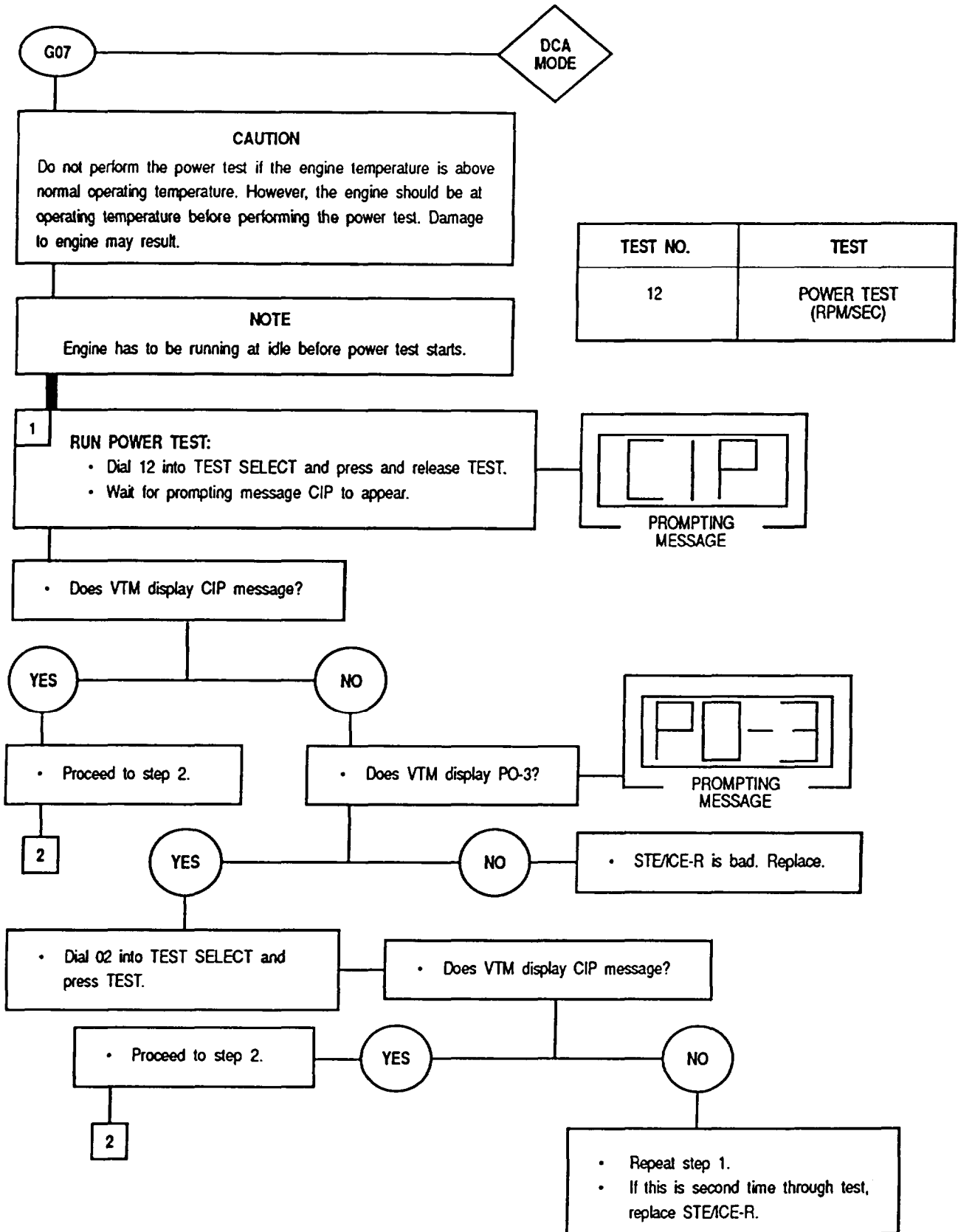

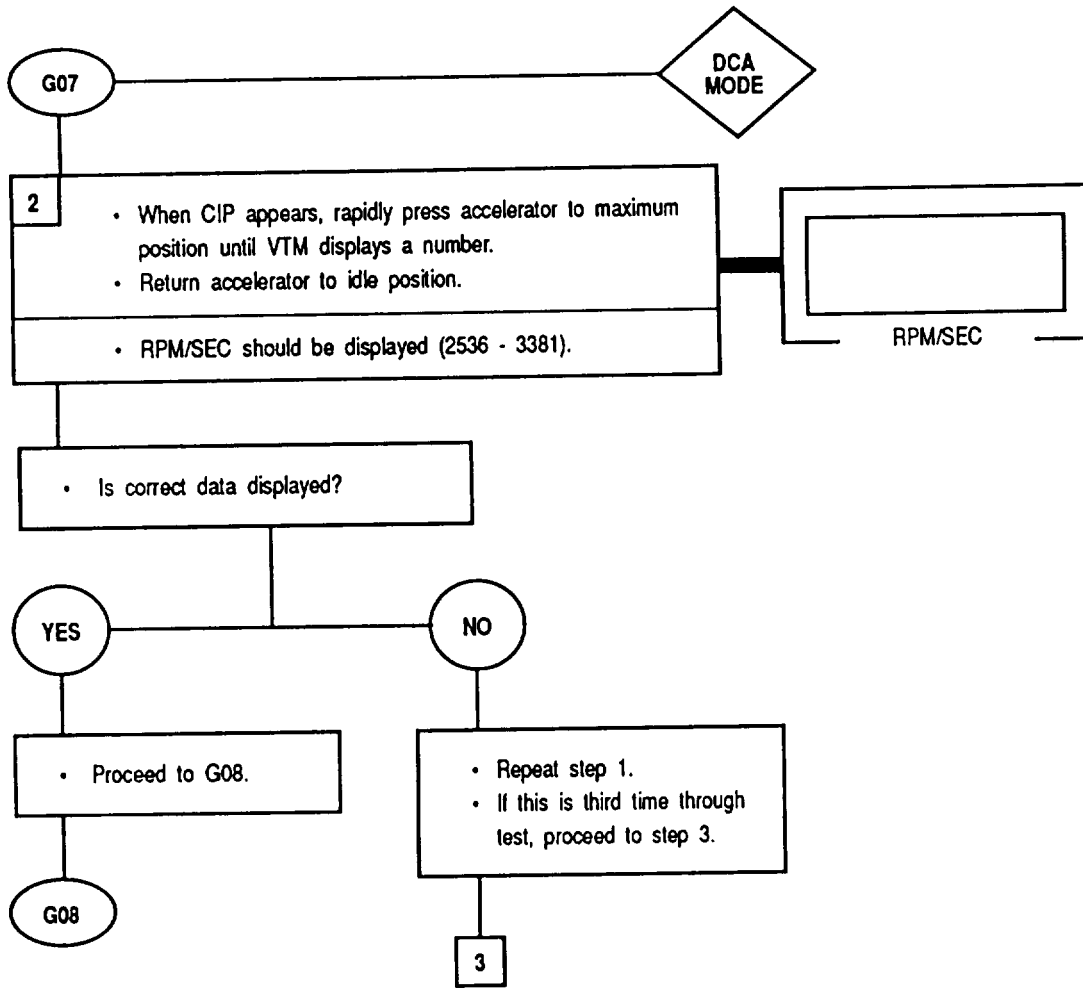

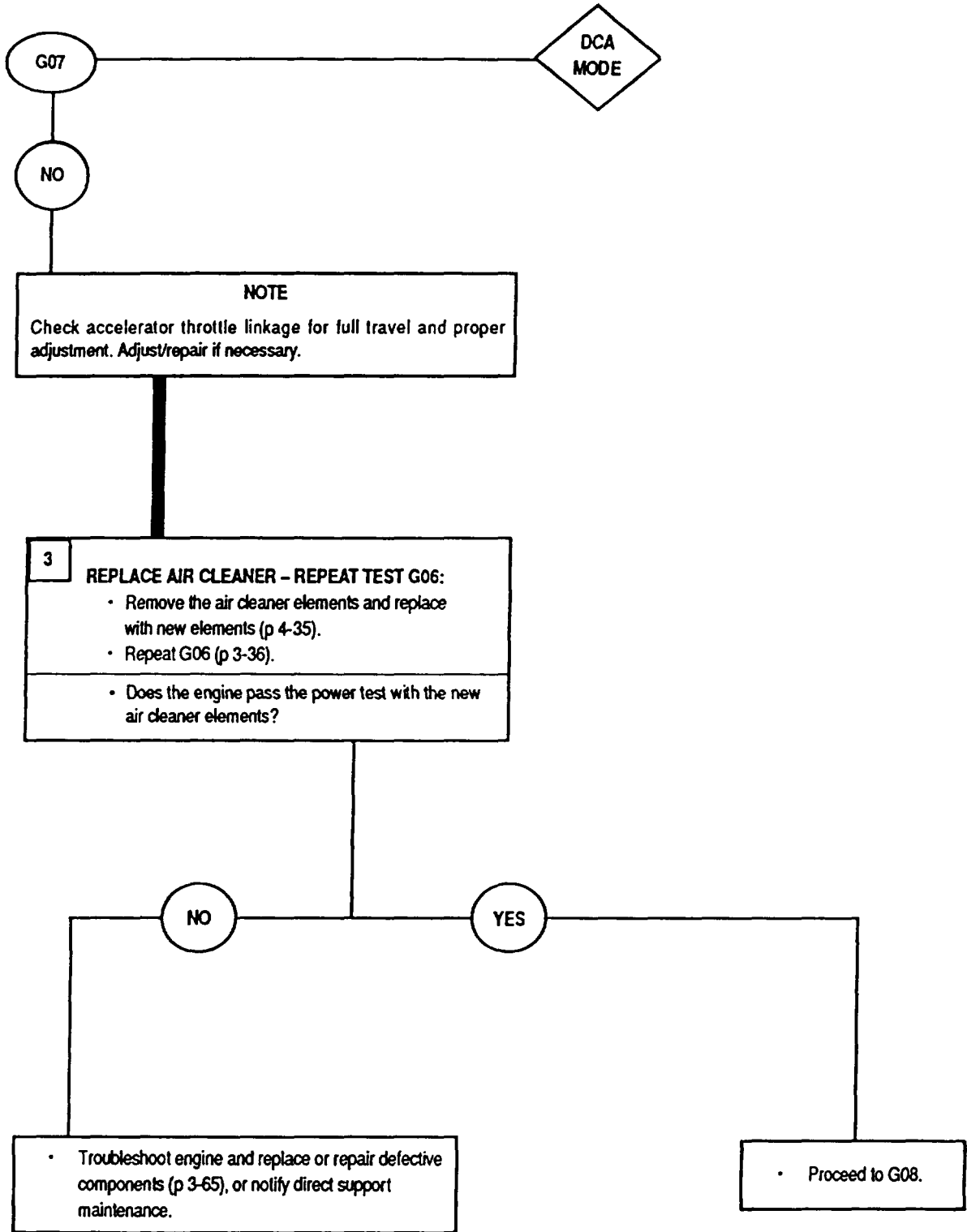

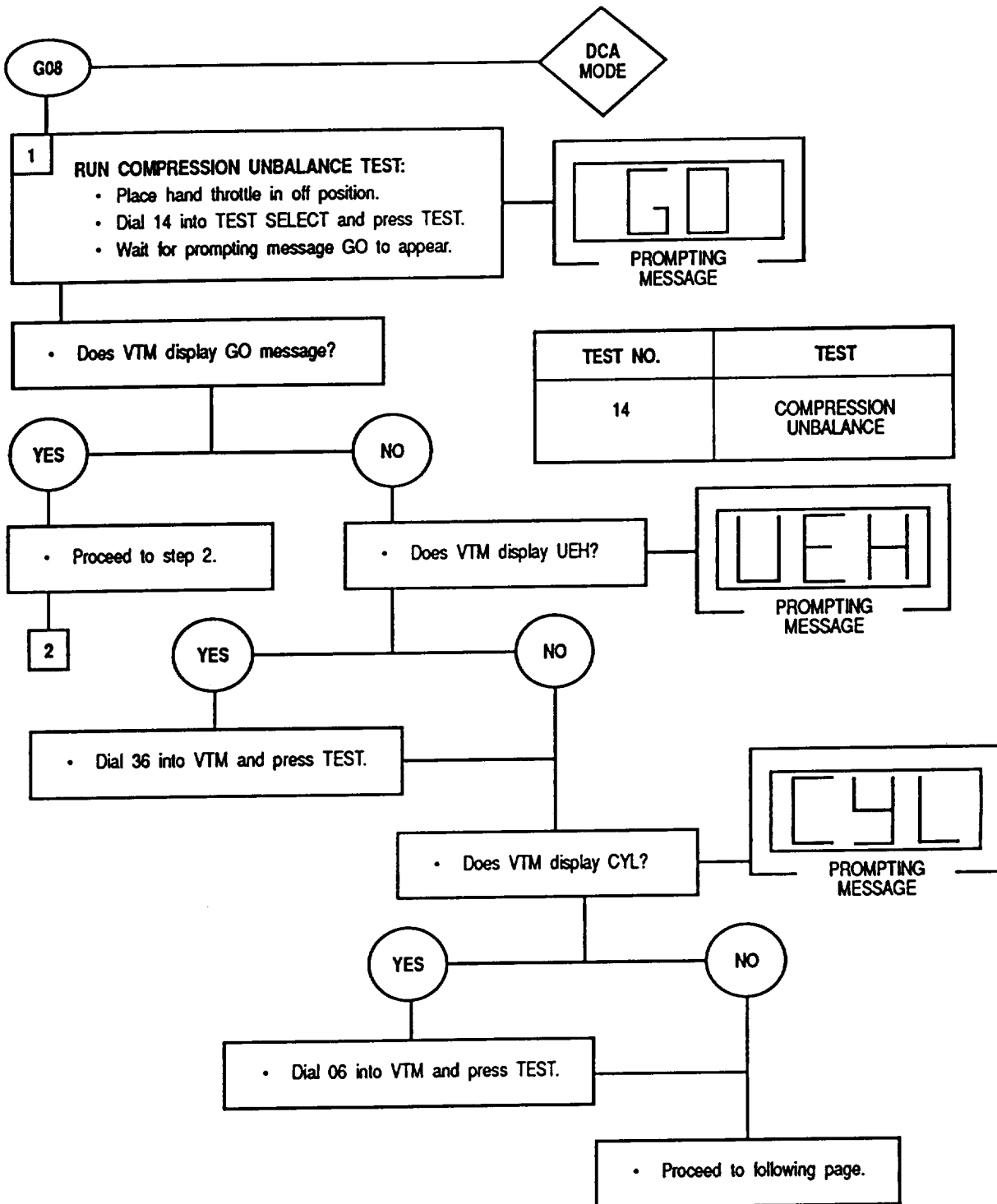

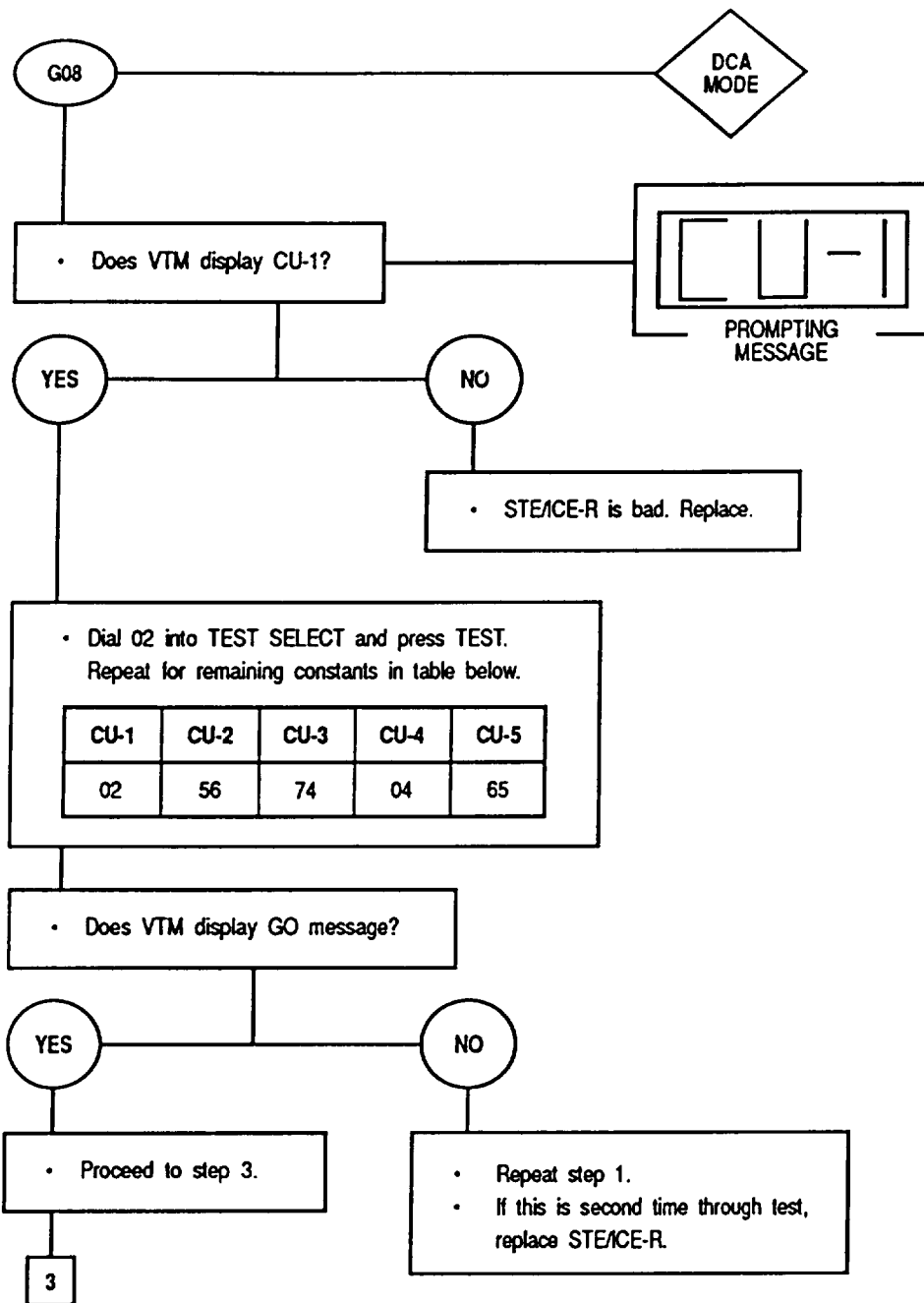

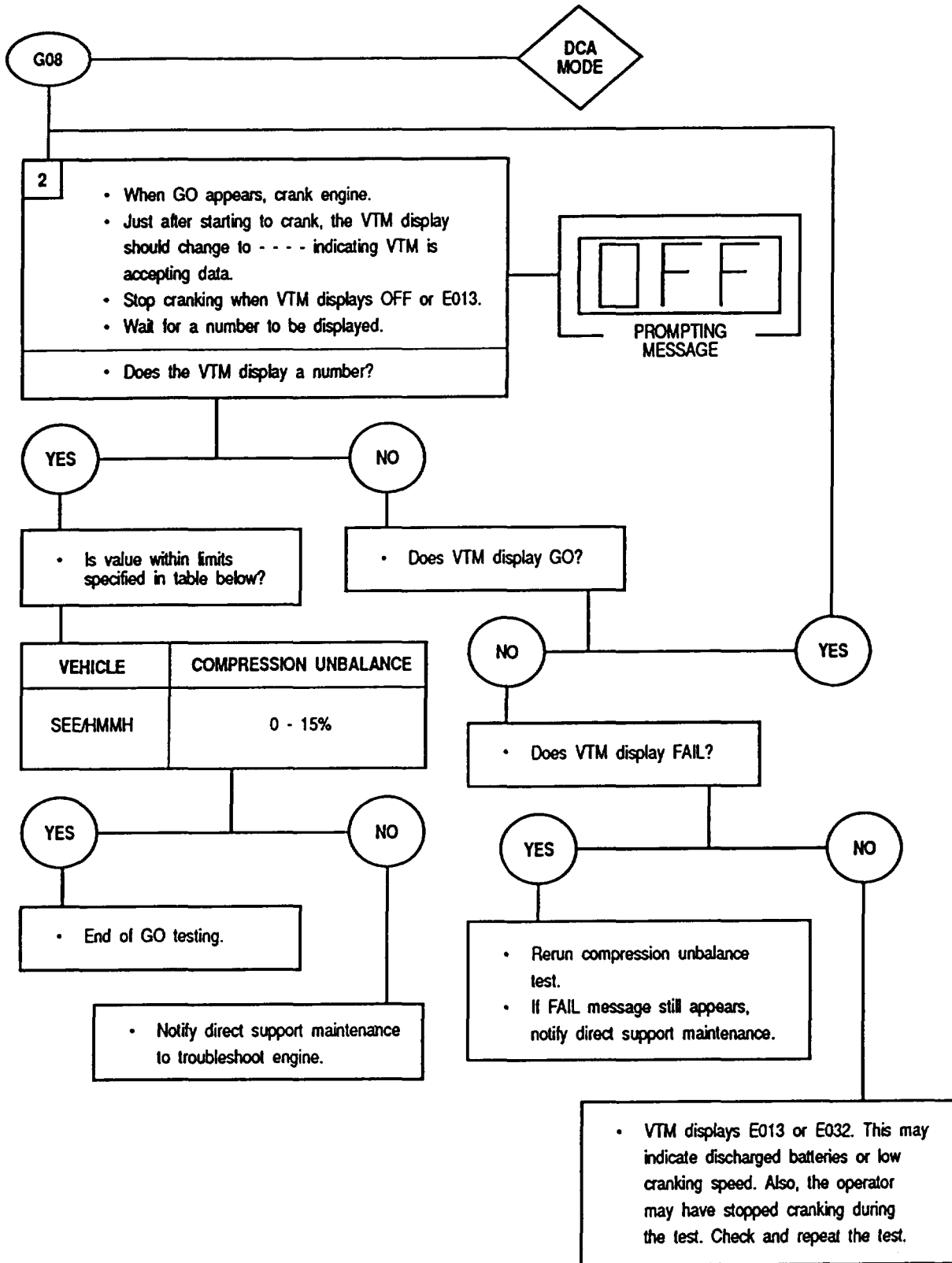

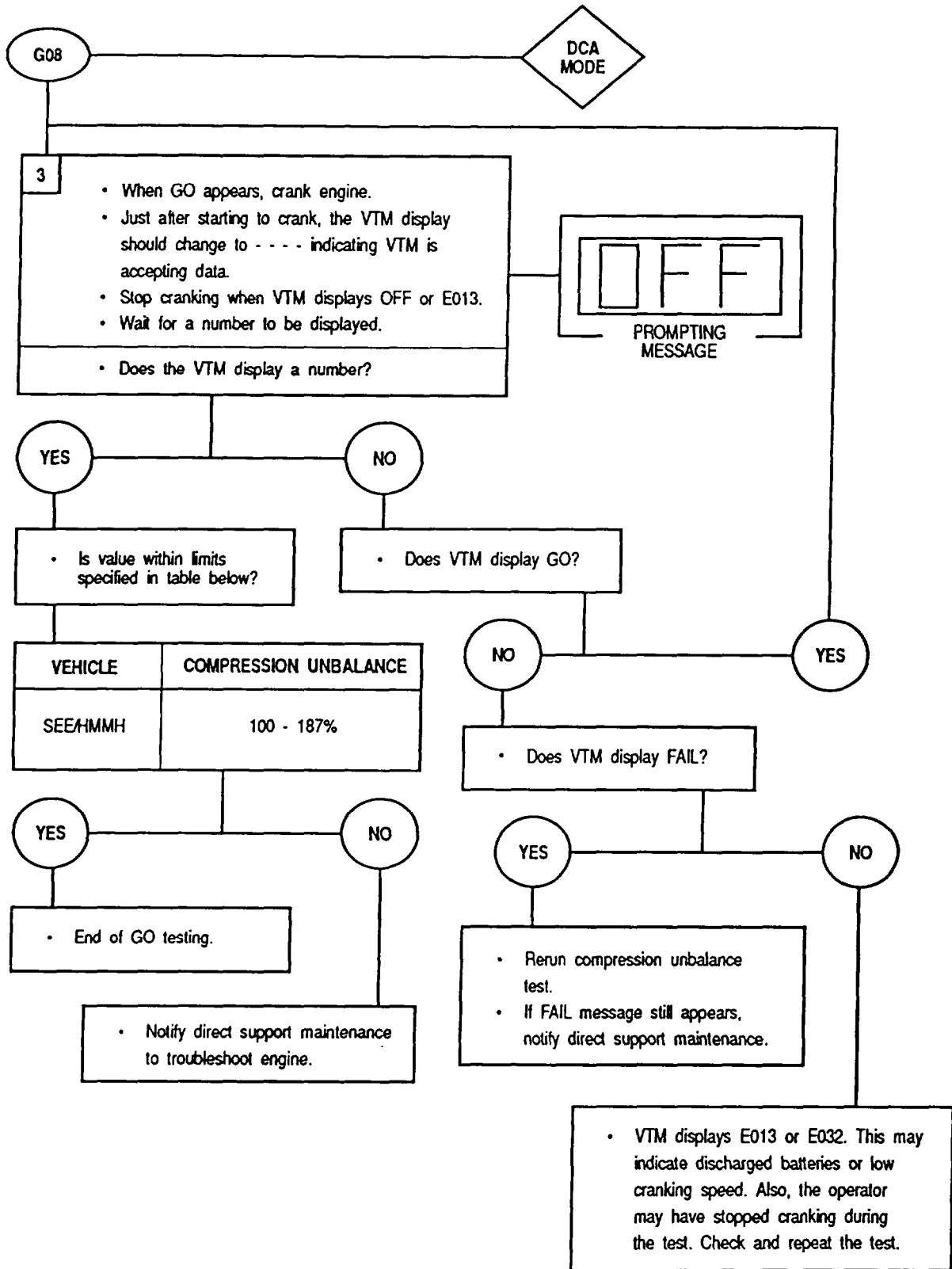

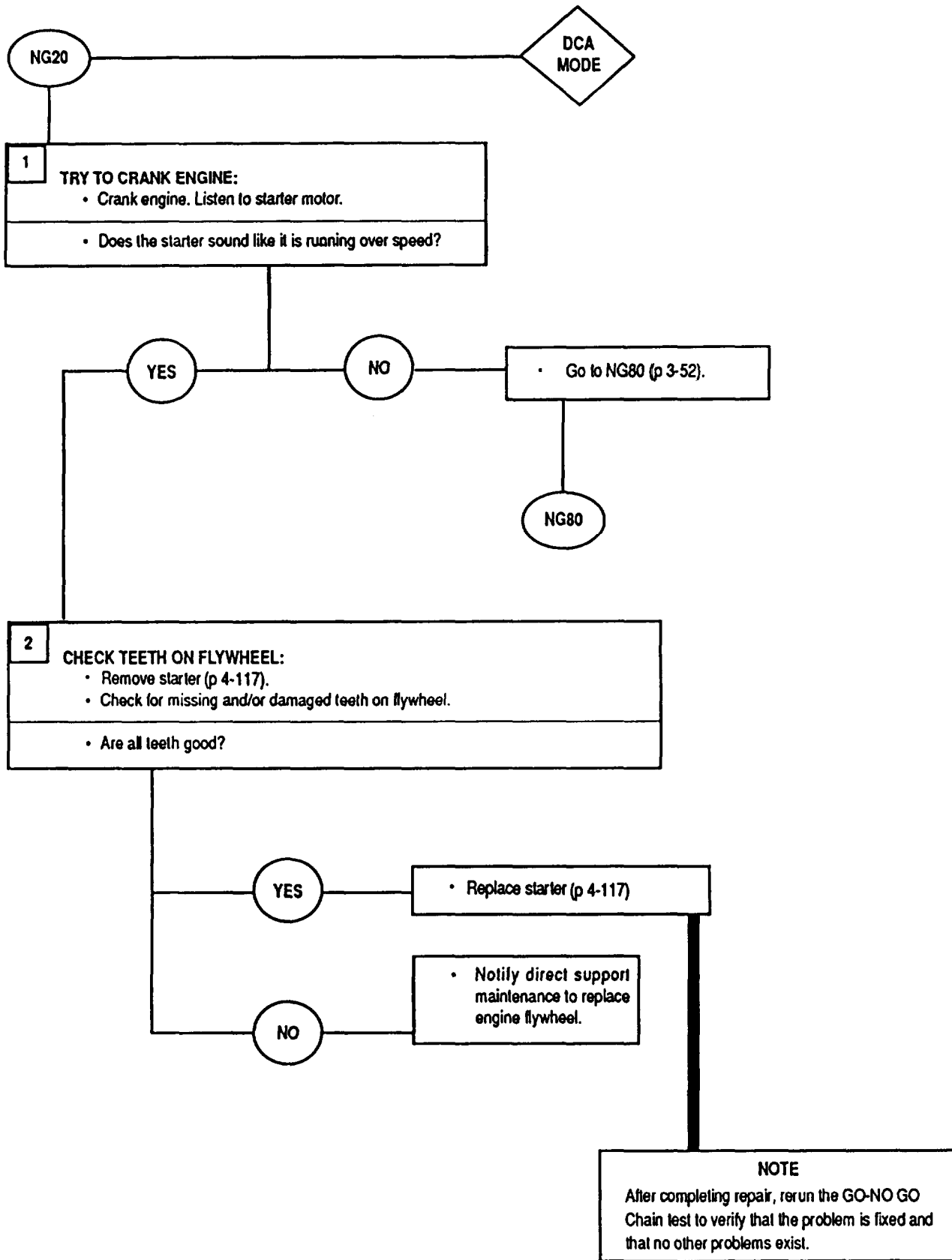

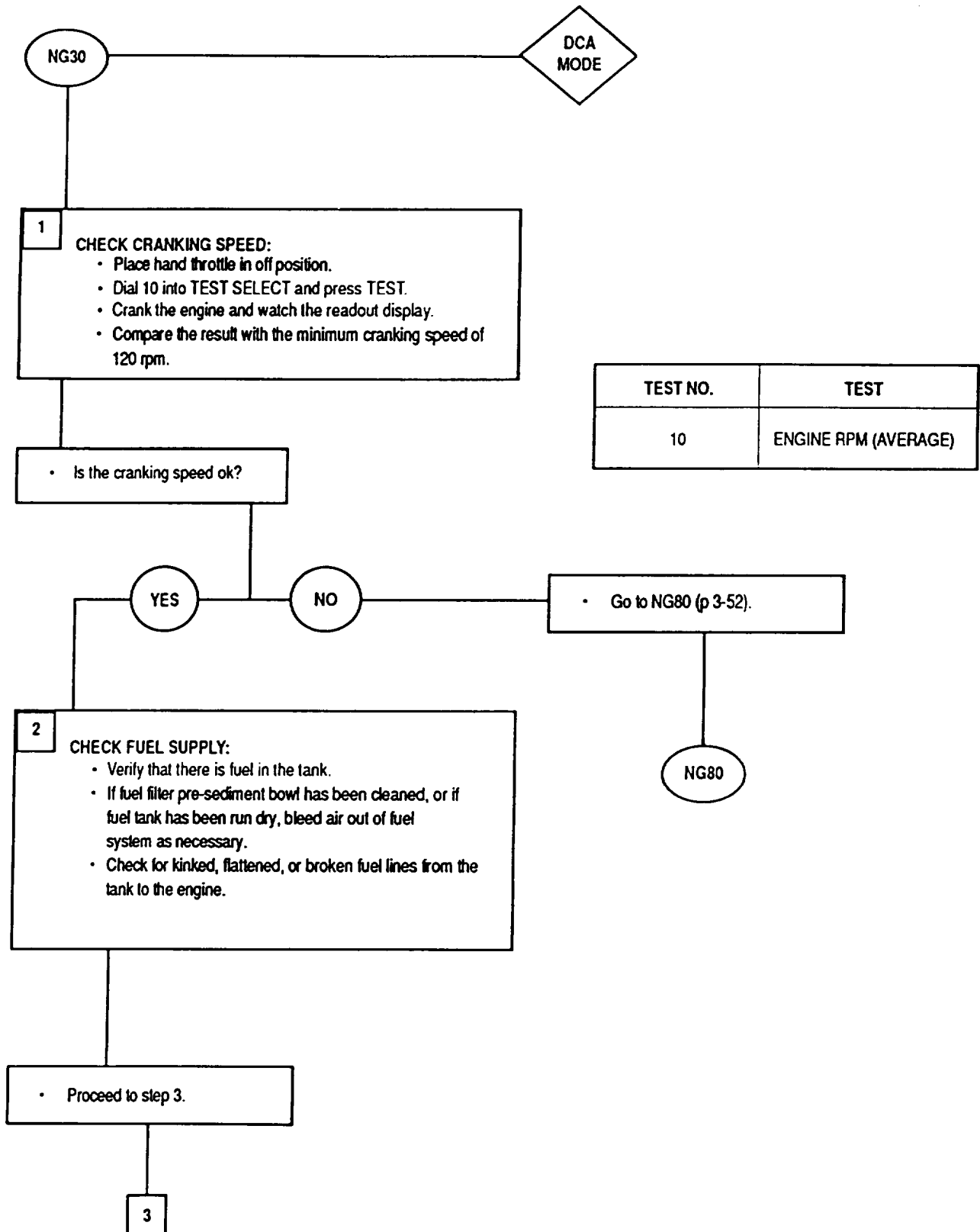

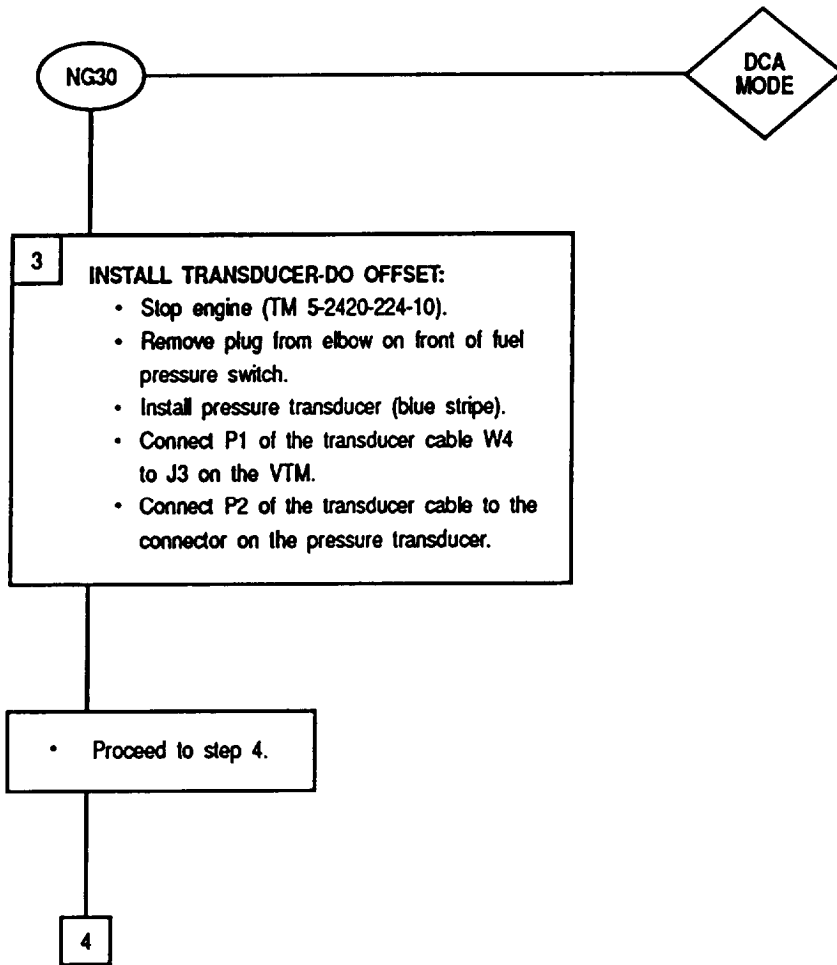

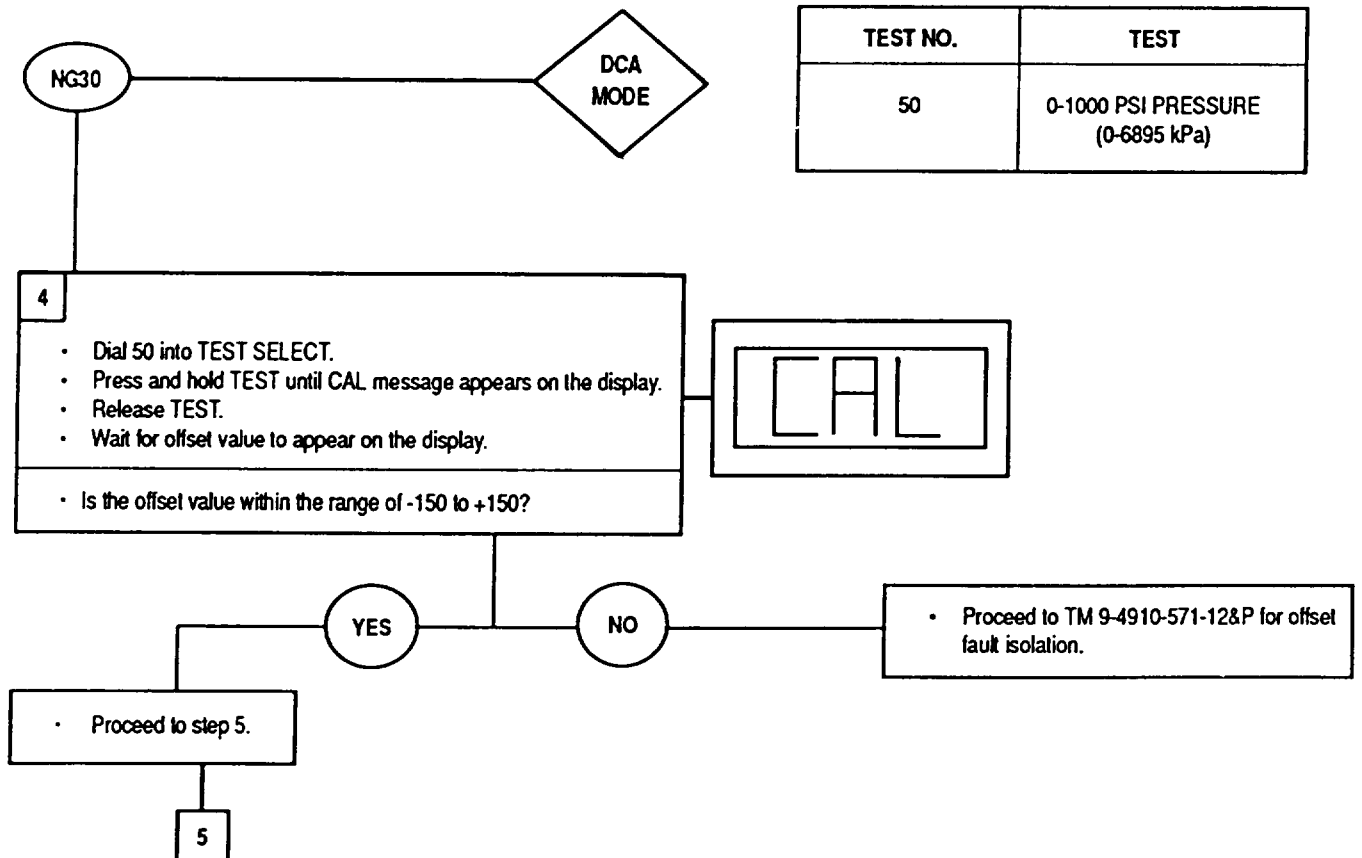

TEST NO.	TEST
50	0-1000 PSI PRESSURE (0-6895 kPa)

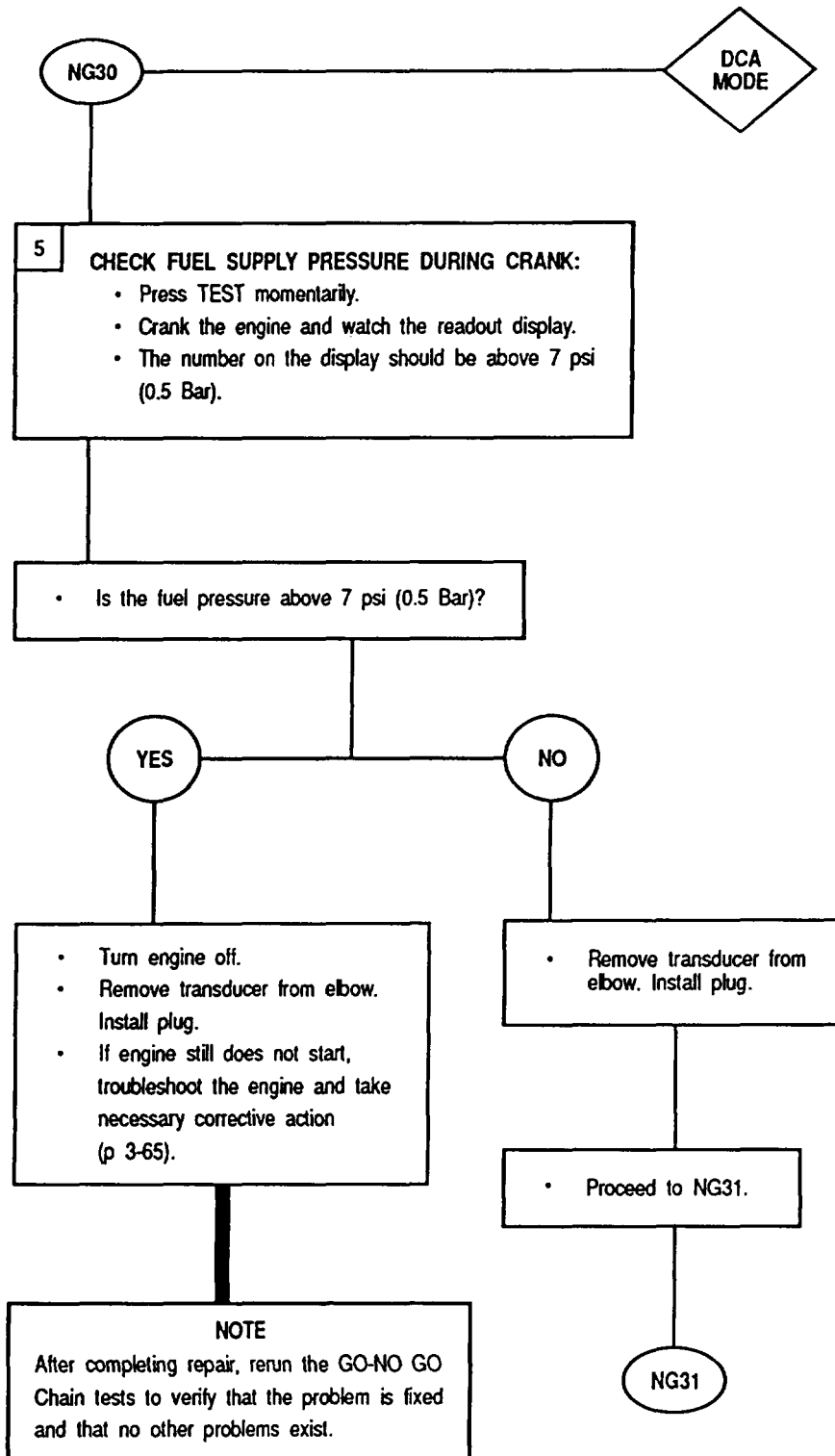

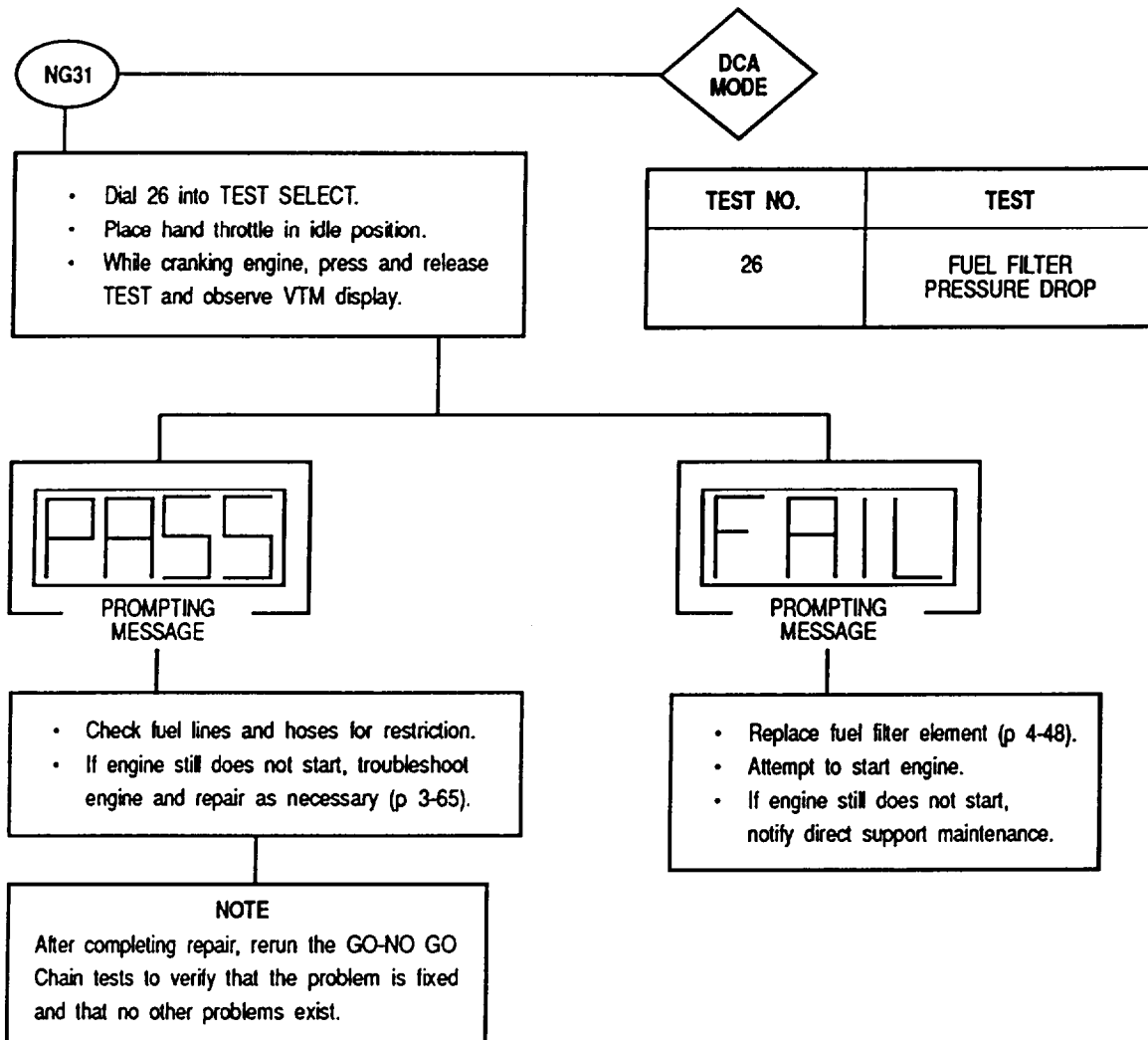

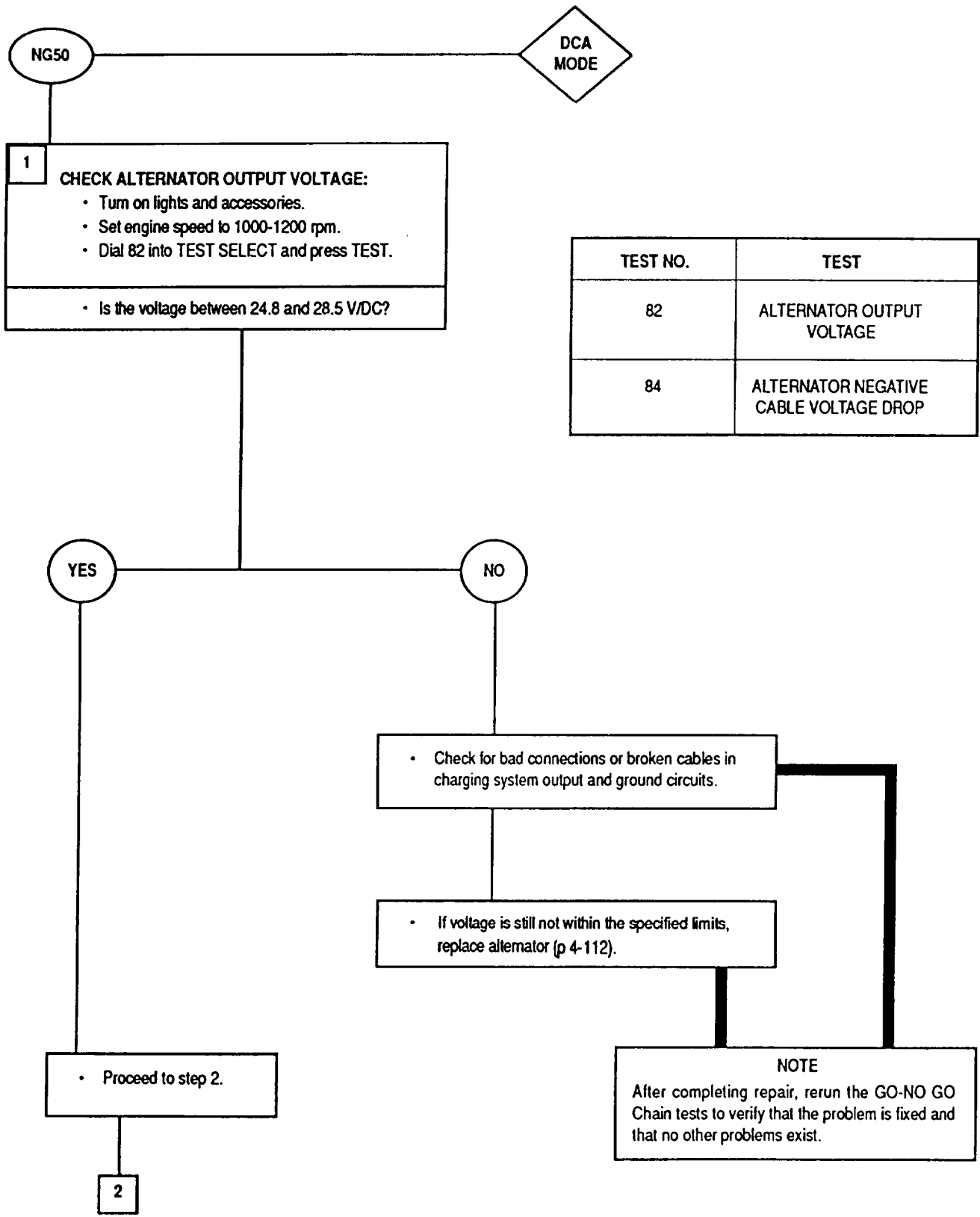

TEST NO.	TEST
82	ALTERNATOR OUTPUT VOLTAGE
84	ALTERNATOR NEGATIVE CABLE VOLTAGE DROP

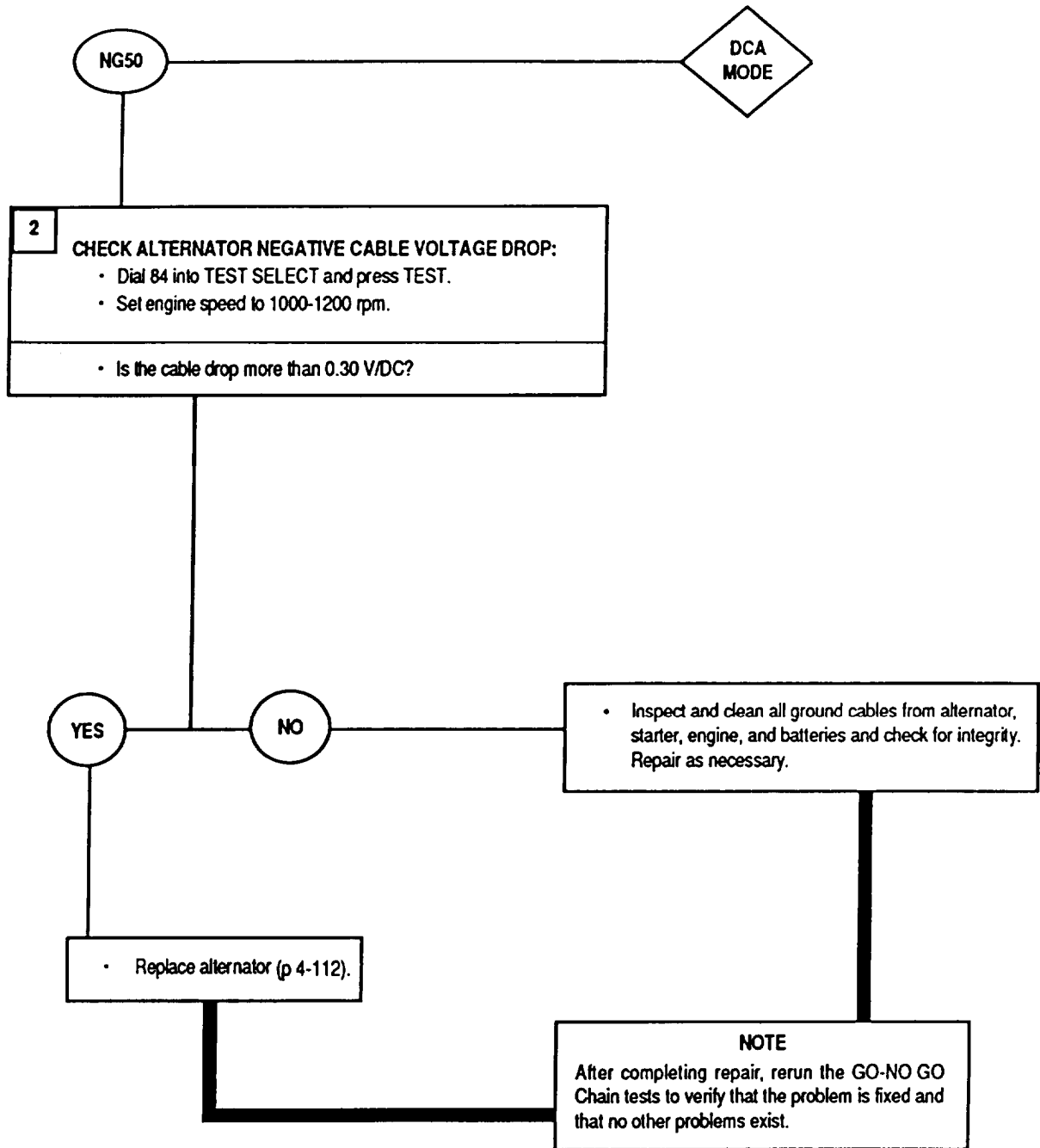

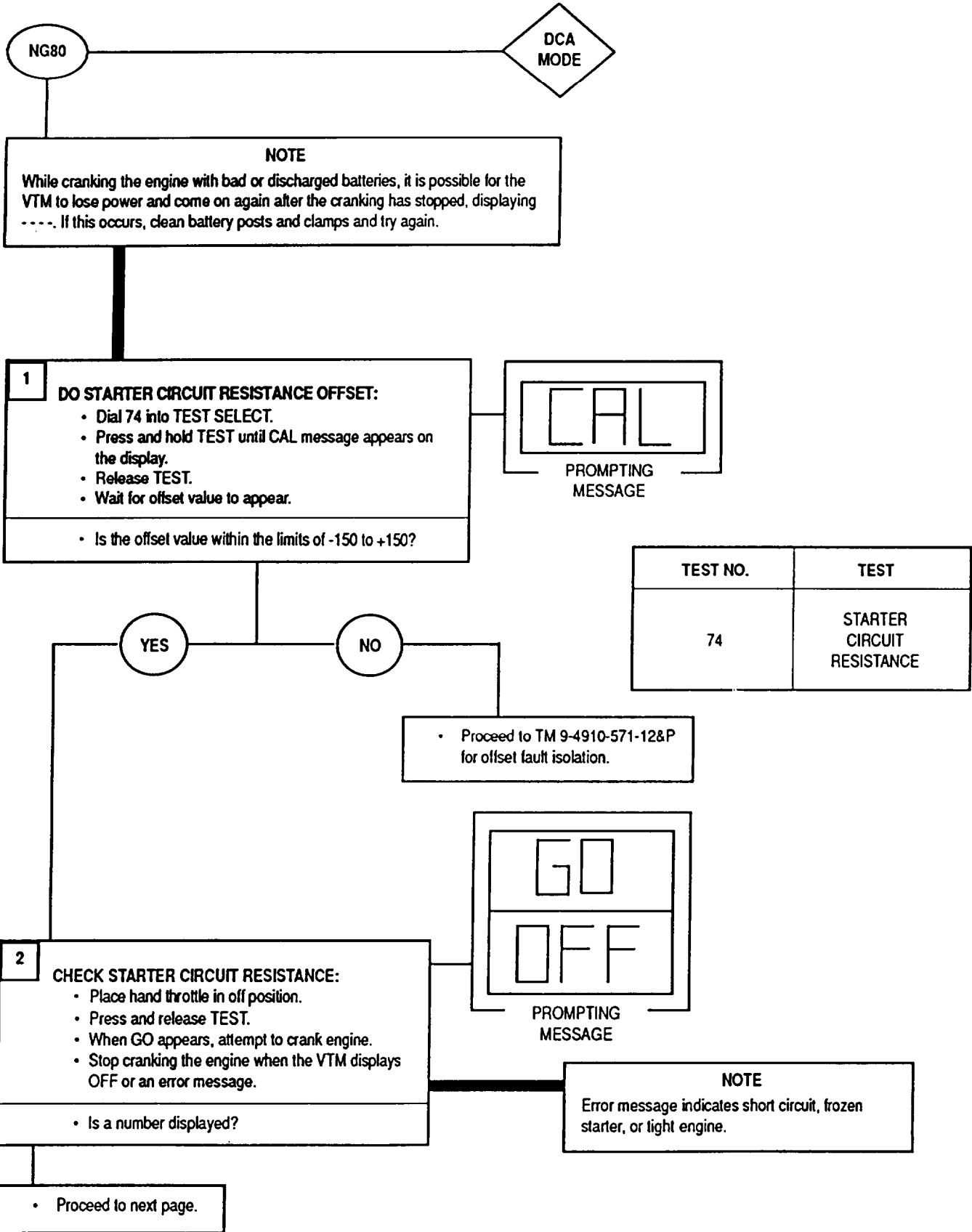

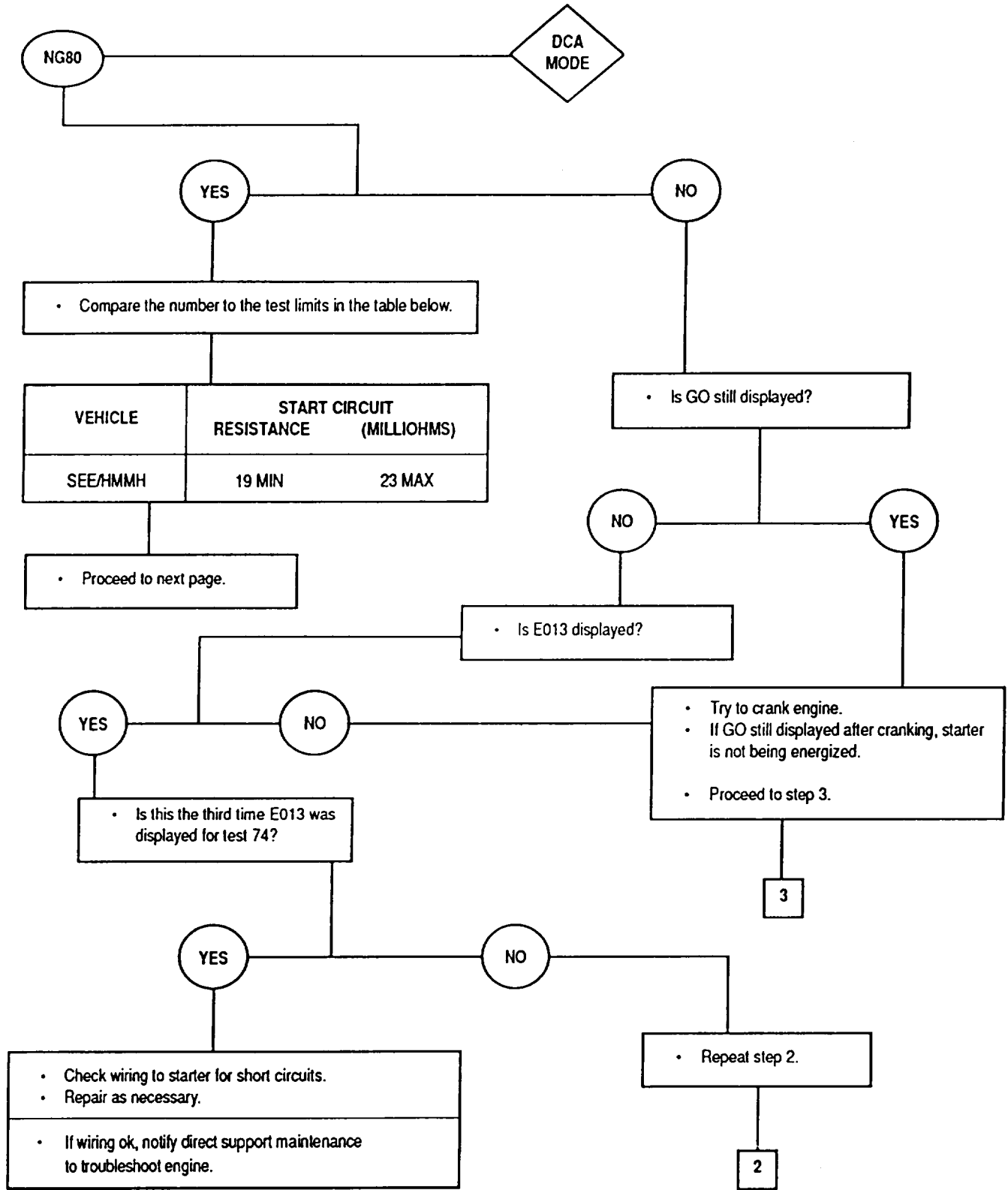

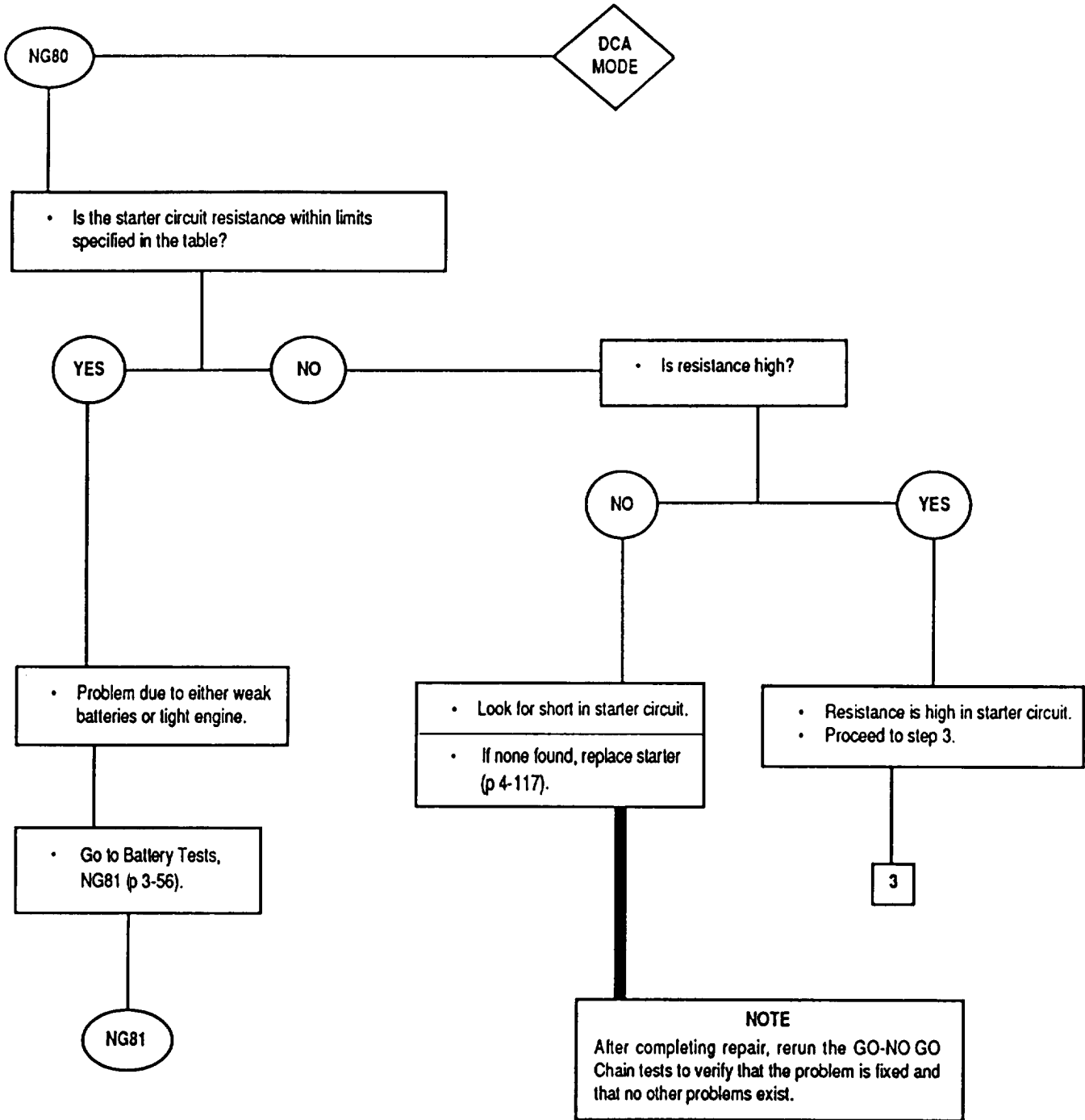

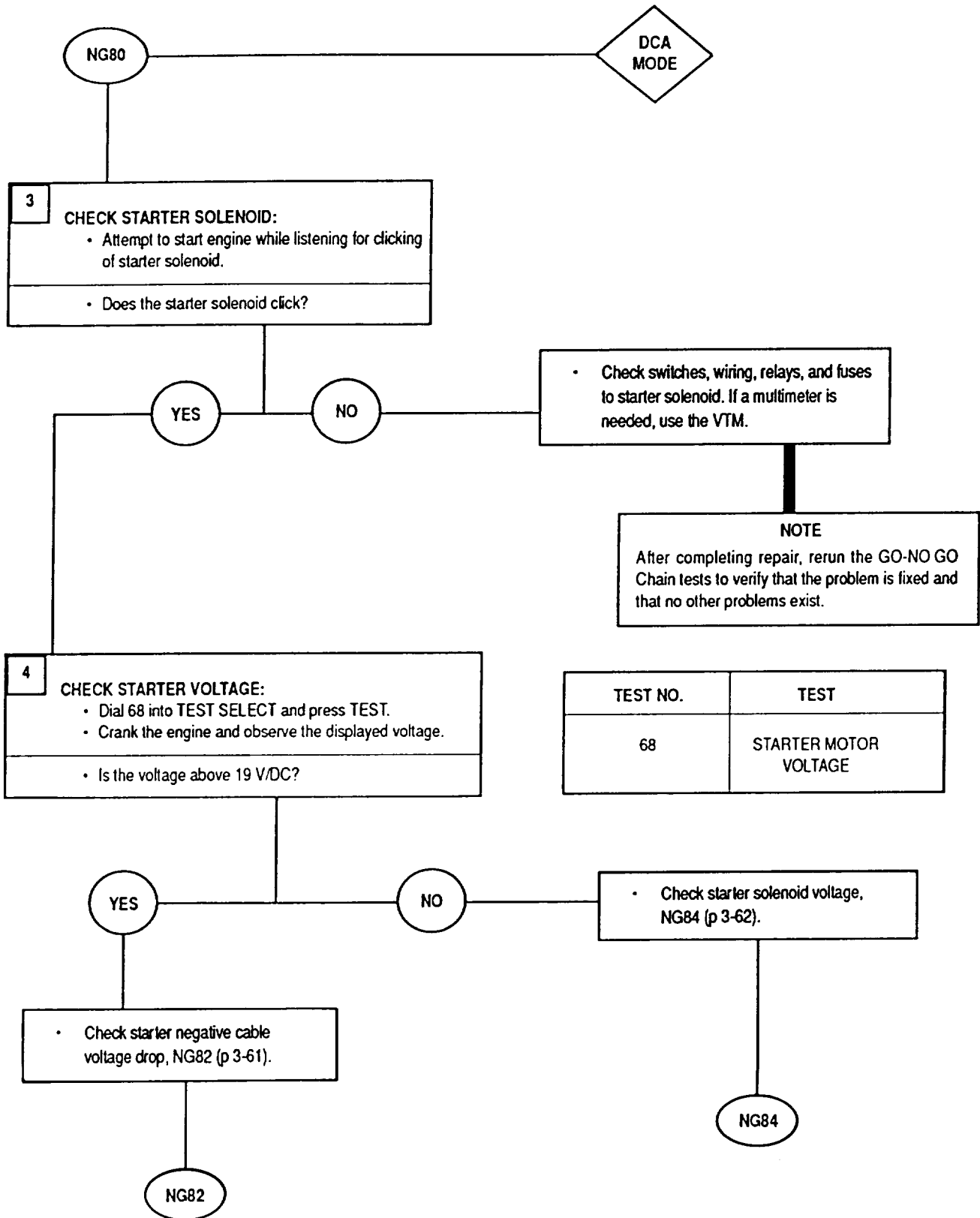

TEST NO.	TEST
68	STARTER MOTOR VOLTAGE

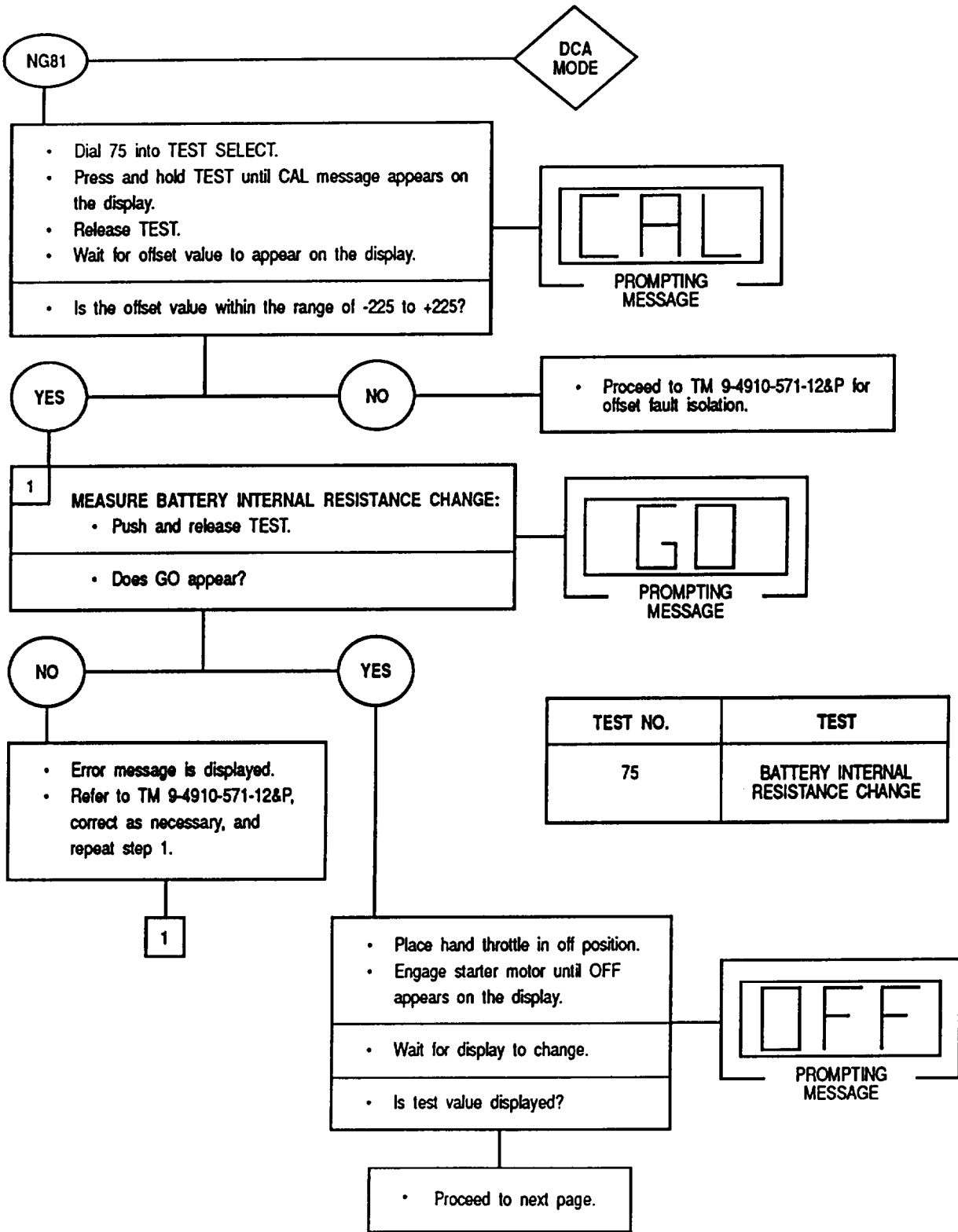

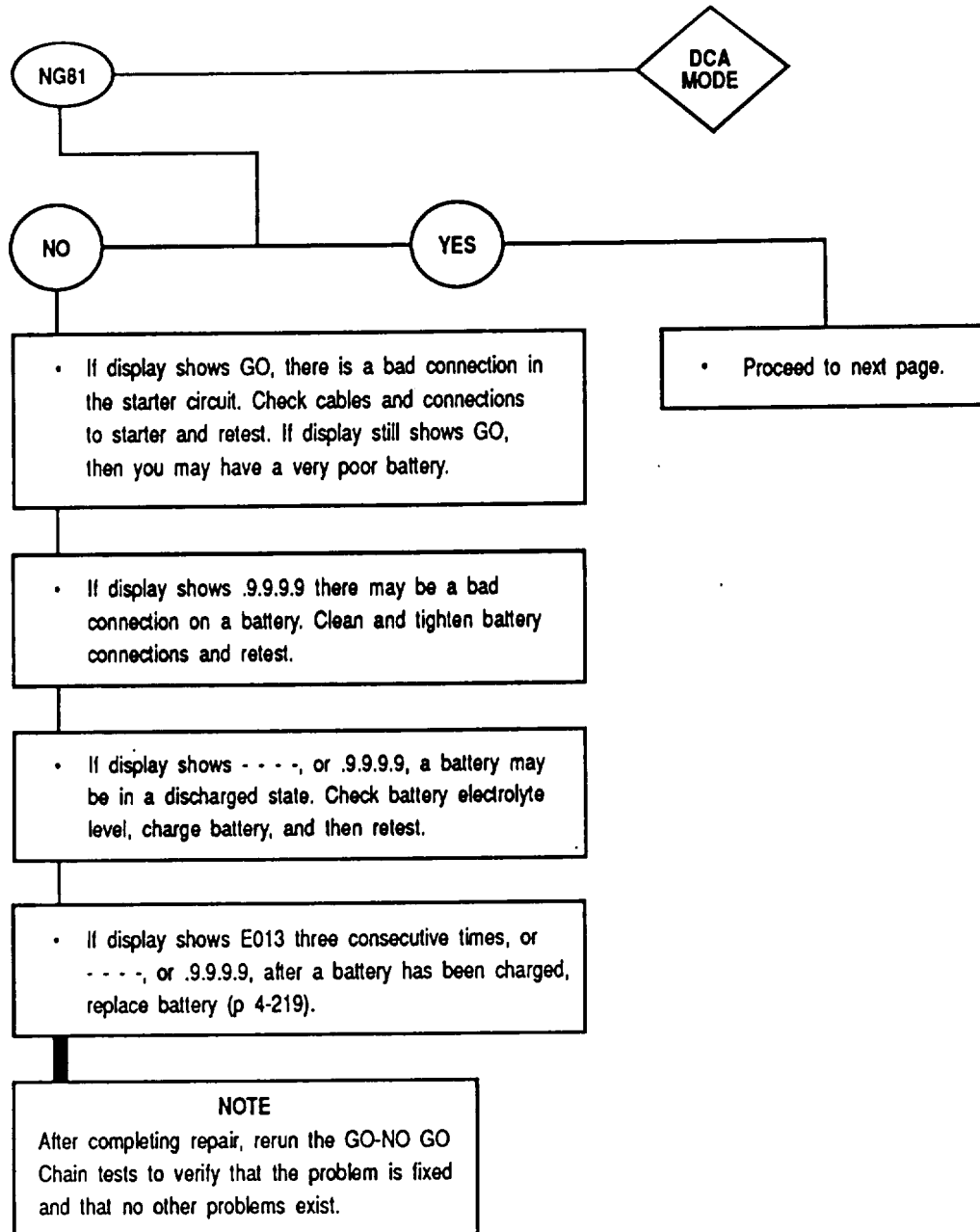

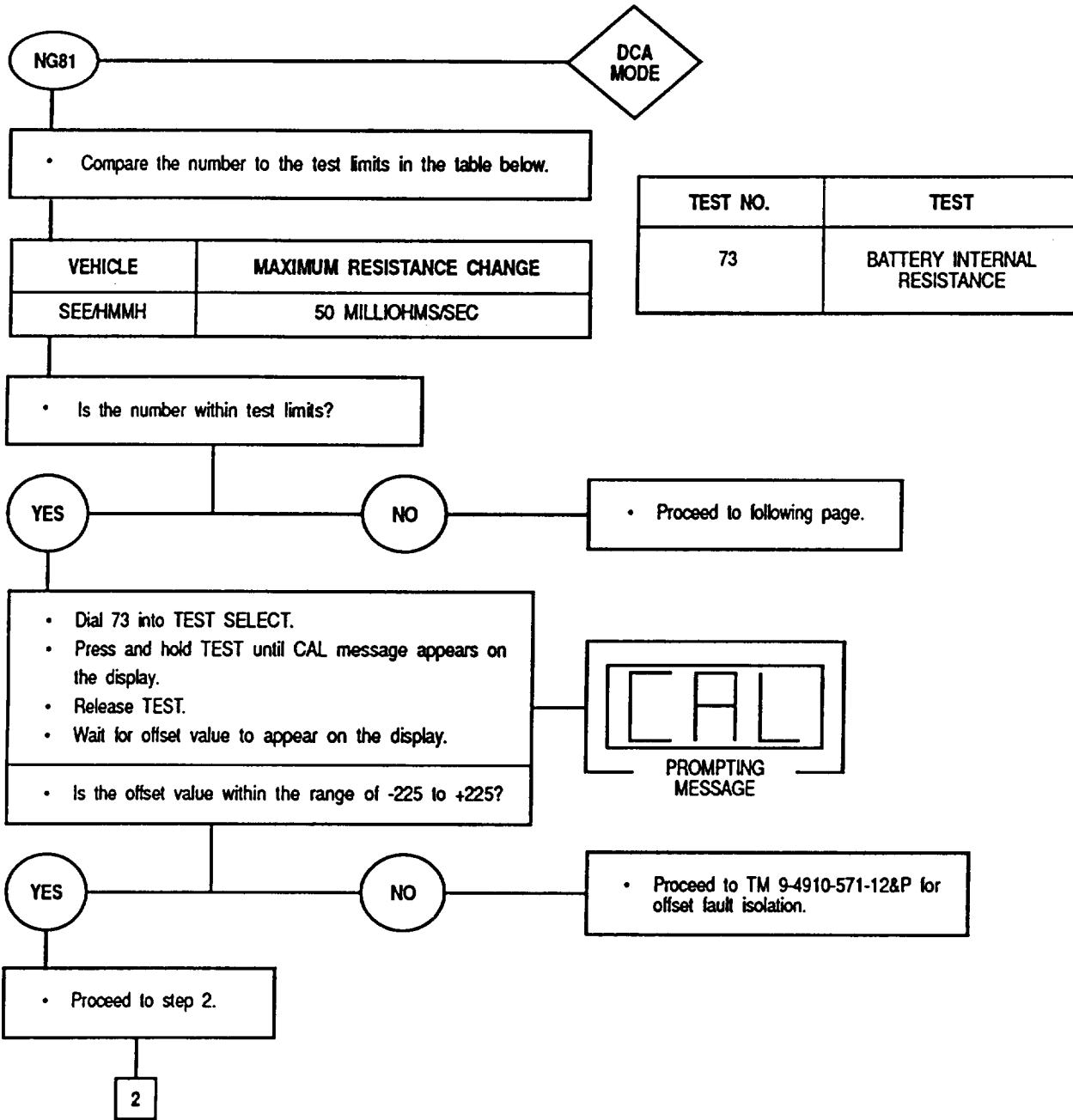

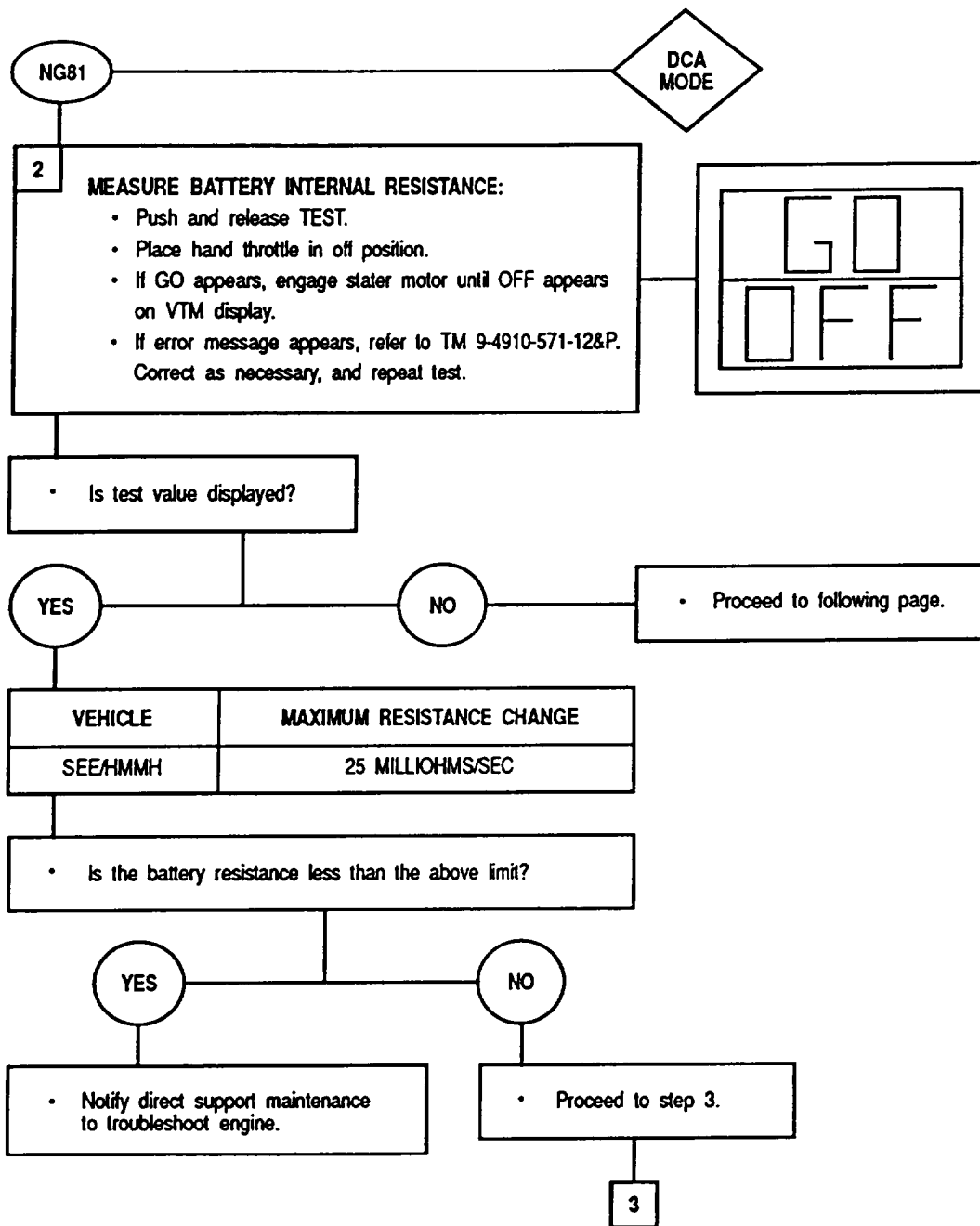

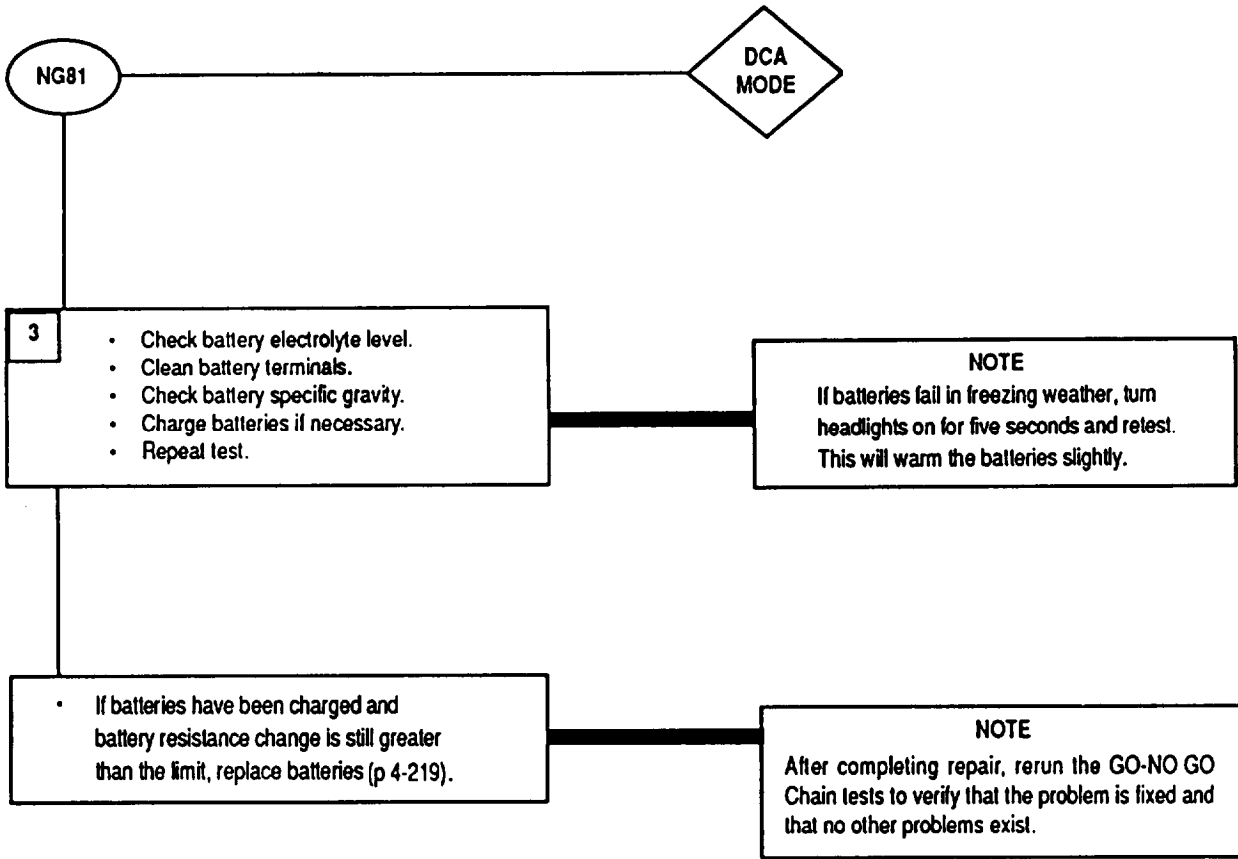

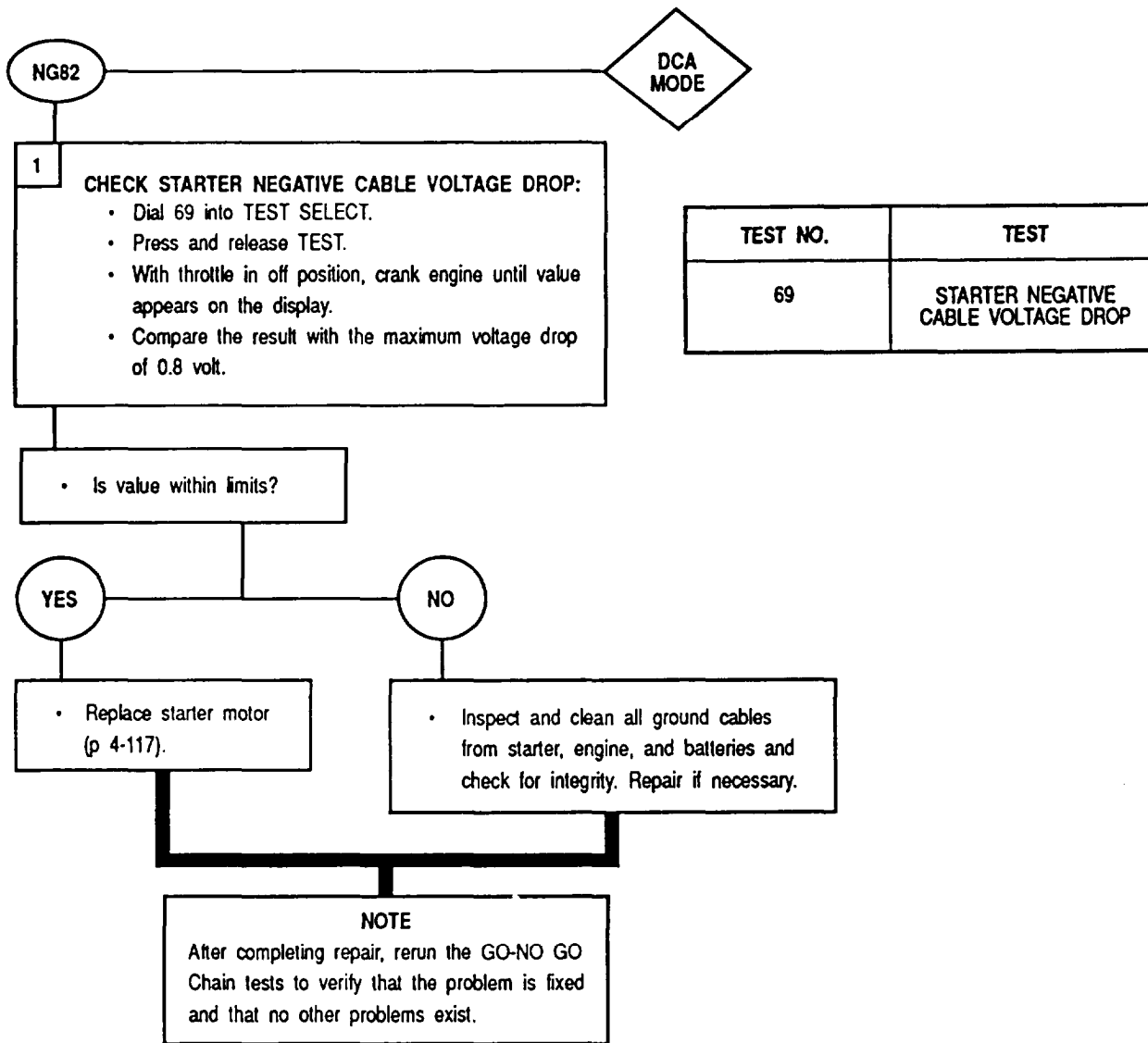

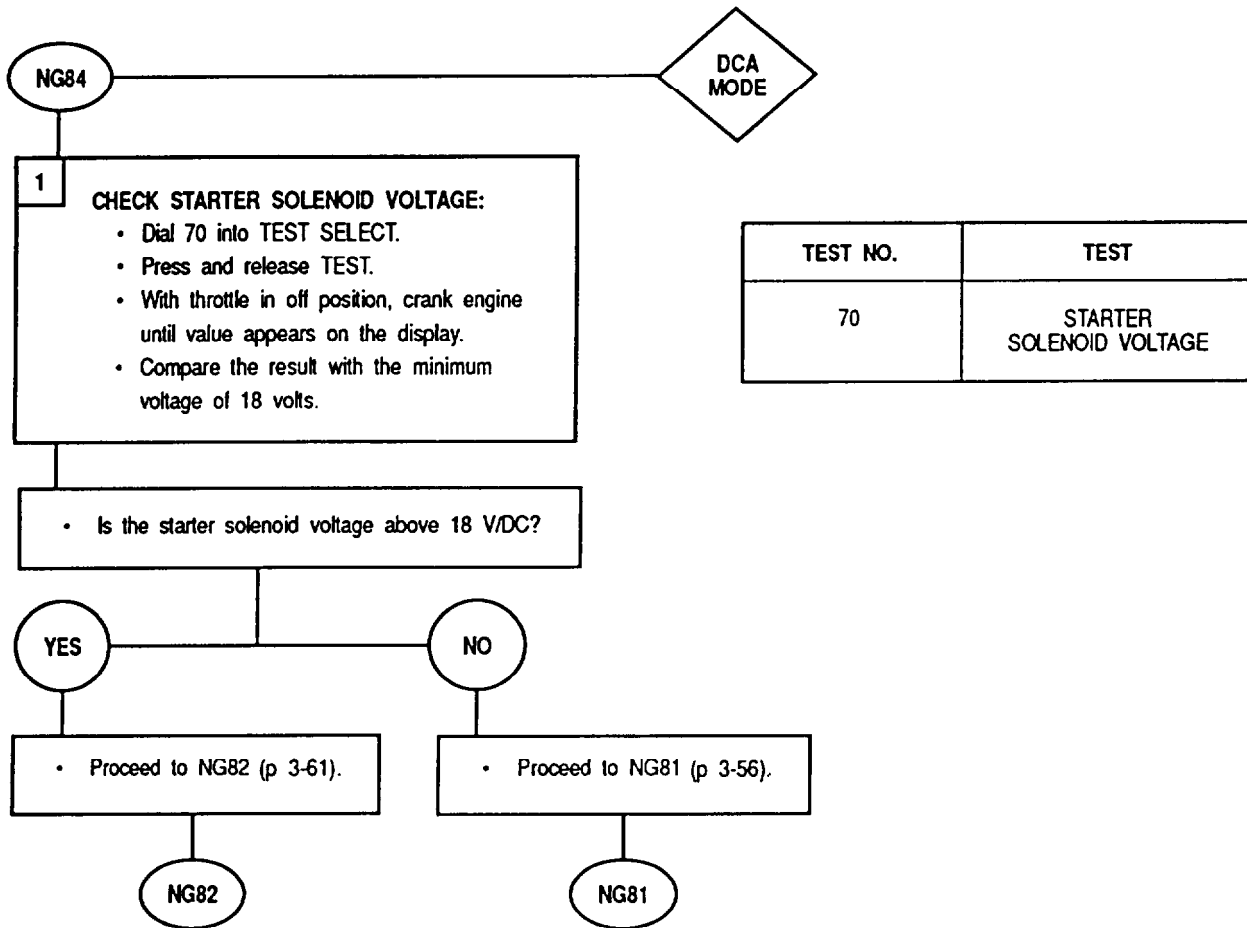

Section IV. TROUBLESHOOTING PROCEDURES

This section contains troubleshooting procedures for the SEE/HMMH.

	Page
Preliminary Troubleshooting Procedures	3-63
Electrical Troubleshooting	3-64
Troubleshooting Symptom Index.	3-65
Troubleshooting Table	3-70

PRELIMINARY TROUBLESHOOTING PROCEDURES

NOTE

Fluid leaks are classified as either Class I, Class II, or Class III:

Class I: Seepage of fluid (as indicated by wetness or discoloration) not great enough to form drops.

Class II: Leakage of fluid great enough to form drops, but not enough to cause drops to drip from the item being checked or observed.

Class III: Leakage of fluid great enough to form drops that fall from the item being checked or observed.

Before starting any specific troubleshooting procedures, perform the following:

1. Visually check for ruptured oil hoses or tubes, and for Class II or Class III leaks.
2. Check for mechanical jamming or binding caused by rocks or other foreign matter.
3. Check fluid levels in subject area and service as required (LO 5-2420-224-12).
4. Relieve hydraulic pressure (page 2-23) and air pressure (page 2-23) before opening any hydraulic or air lines.

ELECTRICAL TROUBLESHOOTING

WARNING

Do not remove, install, connect, or disconnect any electrical component unless vehicle MASTER disconnect switch is OFF. To do so could result in injury to personnel.

CAUTION

If checking for continuity, MASTER disconnect switch must be OFF to prevent damage to equipment.

NOTE

If checking for +24 VDC, MASTER disconnect switch must be ON.

Before starting detail troubleshooting procedures, review the wiring diagram to thoroughly familiarize yourself with the circuit(s) involved. Analyze the symptoms and conditions and use common sense and logic to determine the most likely cause of the problem, then troubleshoot that circuit first. The more information you have concerning the problem, the easier it will be to troubleshoot.

Isolate to the subsystem level (in cases where more than one subsystem is involved); next isolate the problem to a single circuit within the subsystem; then, isolate the problem to the faulty component using the troubleshooting symptom index.

Frayed, broken, loose, or corroded wiring is a common source of problems in any electrical circuit. Always make visual inspection before starting detail troubleshooting. Observe, in particular, contacts to ground. Components with case grounds are especially troublesome.

Most of the checks are made by voltage checks. Instructions prior to the step may instruct you to disconnect at test point from the potential malfunctioning component. Once the check has been made, either repair the component or go to the referenced step. When ready to make the prescribed check, apply power to the circuit (if required). A helper may be required if the switch or power source is out of reach.

When making continuity checks, make sure the test equipment is isolated from the power source.

Troubleshooting Symptom Index

Malfunction Number	Malfunction	Troubleshooting Procedure Page
ENGINE		
1.	ENGINE WILL NOT CRANK.....	3-70
2.	STARTER CONTINUES TO RUN AFTER STARTER SWITCH RELEASED	3-78
3.	ENGINE CRANKS SLOWLY.....	3-79
4.	ENGINE CRANKS BUT WILL NOT START OR HARD TO START	3-79
5.	ENGINE RUNS ROUGH OR LACKS POWER	3-80
6.	FUEL CONSUMPTION EXCESSIVE.....	3-82
7.	DECELERATION SLOW OR UNEVEN.	3-82
8.	IDLE SPEED ERRATIC	3-83
9.	ENGINE KNOCKS WHEN COLD	3-83
10.	OIL PRESSURE GAGE READS LOW OR NO OIL PRESSURE	3-83
11.	ENGINE USES TOO MUCH OIL	3-85
AIR INTAKE SYSTEM		
12.	AIR CLEANER RESTRICTOR INDICATOR LIGHT LIGHTS	3-86
EXHAUST SYSTEM		
13.	EXHAUST FUMES ENTER CAB	3-86
14.	EXHAUST NOISE EXCESSIVE	3-86
COOLING SYSTEM		
15.	LOSS OF ENGINE COOLANT.	3-87
16.	ENGINE OVERHEATS	3-87
ELECTRICAL SYSTEM		
17.	NO ELECTRICAL POWER	3-88
18.	RIGHT FRONT AUXILIARY HEADLIGHT LOW BEAM WILL NOT LIGHT	3-91
19.	RIGHT FRONT AUXILIARY HEADLIGHT HIGH BEAM WILL NOT LIGHT	3-94
20.	RIGHT FRONT HEADLIGHT LOW BEAM WILL NOT LIGHT	3-96
21.	RIGHT FRONT HEADLIGHT HIGH BEAM WILL NOT LIGHT	3-98
22.	LEFT FRONT AUXILIARY HEADLIGHT LOW BEAM WILL NOT LIGHT	3-101
23.	LEFT FRONT AUXILIARY HEADLIGHT HIGH BEAM WILL NOT LIGHT	3-103
24.	LEFT FRONT HEADLIGHT LOW BEAM WILL NOT LIGHT	3-106
25.	LEFT FRONT HEADLIGHT HIGH BEAM WILL NOT LIGHT	3-108
26.	RIGHT FRONT TURN SIGNAL WILL NOT LIGHT	3-110
27.	RIGHT FRONT MARKER LIGHT WILL NOT LIGHT	3-112
28.	RIGHT FRONT BLACKOUT MARKER LIGHT WILL NOT LIGHT	3-114
29.	LEFT FRONT TURN SIGNAL WILL NOT LIGHT	3-116
30.	LEFT FRONT MARKER LIGHT WILL NOT LIGHT	3-118
31.	LEFT FRONT BLACKOUT MARKER LIGHT WILL NOT LIGHT	3-120
32.	FRONT BLACKOUT LIGHT WILL NOT LIGHT	3-122
33.	HORN WILL NOT SOUND	3-124
34.	WINDSHIELD WASHER PUMP WILL NOT OPERATE	3-126
35.	WINDSHIELD WIPERS WILL NOT OPERATE	3-128
36.	DOME LIGHT WILL NOT LIGHT	3-131
37.	CAB HEATER FAN WILL NOT OPERATE	3-133

Troubleshooting Symptom Index (Cont)

Malfunction Number	Malfunction	Troubleshooting Procedure Page
38.	PANEL LIGHTS WILL NOT LIGHT	3-134
39.	TACHOMETER SHOWS NO INDICATION	3-137
40.	LOW PRESSURE WARNING BUZZER WILL NOT SOUND	3-139
41.	TURN SIGNAL INDICATOR LIGHT WILL NOT LIGHT	3-140
42.	HIGH BEAM INDICATOR LIGHT WILL NOT LIGHT	3-142
43.	CHARGE INDICATOR LIGHT STAYS ON DURING OPERATION	3-144
44.	WATER TEMPERATURE GAGE SHOWS NO INDICATION	3-146
45.	FUEL LEVEL GAGE SHOWS NO INDICATION	3-148
46.	AMMETER (VOLTMETER) SHOWS NO INDICATION.	3-150
47.	COLD START SYSTEM WILL NOT OPERATE	3-152
48.	DRIVER SIDE WINDSHIELD HEATER WILL NOT OPERATE.	3-156
49.	PASSENGER SIDE WINDSHIELD HEATER WILL NOT OPERATE	3-160
50.	HAZARD WARNING LIGHTS WILL NOT LIGHT	3-163
51.	ALL INSTRUMENT CLUSTER PANEL LIGHT INDICATORS WILL NOT LIGHT	3-166
52.	PTO INDICATOR LIGHT WILL NOT LIGHT	3-168
53.	DIFFERENTIAL LOCK INDICATOR LIGHT WILL NOT LIGHT.	3-170
54.	BRAKE INDICATOR LIGHT WILL NOT LIGHT WITH PARKING BRAKE APPLIED	3-172
55.	BRAKE INDICATOR LIGHT WILL NOT LIGHT WHEN BRAKE FLUID. RESERVOIR OR CLUTCH HYDRAULIC RESERVOIR LOW	3-175
56.	BRAKE INDICATOR LIGHT WILL NOT LIGHT WHEN FRONT DISC BRAKE PADS WORN OUT	3-178
57.	AIR CLEANER RESTRICTOR INDICATOR LIGHT WILL NOT LIGHT	3-181
58.	INTERMEDIATE SPEED INDICATOR LIGHT WILL NOT LIGHT	3-184
59.	INTERMEDIATE SPEED WILL NOT ENGAGE	3-186
60.	BRAKE LIGHTS WILL NOT LIGHT WHEN BRAKE PEDAL APPLIED	3-188
61.	RIGHT BRAKE LIGHT WILL NOT LIGHT	3-192
62.	RIGHT TAILLIGHT WILL NOT LIGHT	3-194
63.	RIGHT BLACKOUT TAILLIGHT WILL NOT LIGHT	3-196
64.	RIGHT BLACKOUT BRAKE LIGHT WILL NOT LIGHT	3-198
65.	LEFT BRAKE LIGHT WILL NOT LIGHT	3-200
66.	LEFT TAILLIGHT WILL NOT LIGHT	3-202
67.	LEFT BLACKOUT TAILLIGHT WILL NOT LIGHT	3-205
68.	LEFT BLACKOUT BRAKE LIGHT WILL NOT LIGHT	3-207
69.	WORK LIGHTS WILL NOT LIGHT.	3-210
70.	BACKUP ALARM WILL NOT SOUND	3-212
71.	LOW OIL PRESSURE AND HIGH WATER TEMPERATURE ALARM WILL NOT SOUND WITH PRESS-TO-TEST SWITCH DEPRESSED	3-214
72.	HYDRAULIC SUSPENSION LOCKOUT WILL NOT ENGAGE (HMMH)	3-218
73.	HYDRAULIC SUSPENSION LOCKOUT WILL NOT ENGAGE (HMMH) (REG. NO. UC053E THRU UC053K)	3-236
74.	HYDRAULIC OIL COOLER FANS WILL NOT OPERATE.	3-254
75.	THROTTLE CONTROL SWITCH WILL NOT OPERATE (SEE)	3-256
76.	ALL MACHINE (HYDRAULIC) TOOLS WILL NOT OPERATE	3-258
77.	FRONT LOADER WILL NOT OPERATE USING BUCKET SWITCH (SEE)	3-260
78.	THROTTLE CONTROL SWITCH WILL NOT OPERATE (HMMH)	3-262

Troubleshooting Symptom Index (Cont)

Malfunction Number	Malfunction	Troubleshooting Procedure Page
TRANSMISSION		
79.	TRANSMISSION WILL NOT OPERATE IN ANY FORWARD OR REVERSE GEAR	3-264
80.	TRANSMISSION SLIPS IN ALL RANGES	3-265
81.	PTO WILL NOT ENGAGE	3-266
82.	ALL WHEEL DRIVE/DIFFERENTIAL LOCK WILL NOT ENGAGE/DISENGAGE	3-266
BRAKES AND AIR SYSTEM		
83.	BRAKES FAIL OR BRAKE PEDAL SPONGY	3-267
84.	BRAKING UNEVEN	3-267
85.	BRAKES OVERHEAT	3-268
86.	BRAKES SQUEAL	3-270
87.	BRAKE INDICATOR LIGHT LIGHTS	3-271
88.	TRAILER BRAKE SYSTEM FAILS OR BRAKING WEAK	3-275
89.	AIR SYSTEM HAS NO EFFECT ON BRAKING (HARD BRAKING)	3-276
STEERING		
90.	STEERING WHEEL HARD TO MOVE FULL RIGHT AND FULL LEFT	3-277
91.	STEERING WHEEL HAS TOO MUCH PLAY	3-278
92.	STEERING WHEEL VIBRATES AND/OR VEHICLE WANDERS	3-279
93.	POWER STEERING PUMP NOISY	3-279
94.	POWER STEERING SYSTEM LOSING OIL	3-280
SUSPENSION		
95.	CLUNKING OR CREAKING ON TURNS OR STOPS	3-280
96.	HYDRAULIC SUSPENSION LOCKOUT SYSTEM WILL NOT ENGAGE (HMMH)	3-282
97.	ONE SIDE OF HYDRAULIC SUSPENSION LOCKOUT WILL NOT ENGAGE (HMMH)	3-282
HYDRAULIC SYSTEM		
98.	HYDRAULIC PUMP NOISY	3-282
99.	HYDRAULIC OIL FOAMY (FRONT LOADER/FORKLIFT, BACKHOE/CRANE, AND HYDRAULIC TOOLS OPERATE ERRATICALLY)	3-283
100.	HYDRAULIC OIL OVERHEATS	3-283
FORKLIFT (HMMH)		
101.	FORKLIFT WILL NOT MOVE (EMPTY)	3-284
102.	FORKLIFT WILL NOT LIFT LOAD	3-284
103.	LIFT CYLINDER DRIFTS DOWN	3-284
104.	MASTER PLUNGER DRIFTS UP WHEN LOAD LIFTED, THEN STOPS	3-285
105.	TILT CYLINDER DRIFTS	3-285
106.	ROTATOR CYLINDER RIFTS.	3-287
107.	FORKLIFT TILTS WITH ROTATE BUTTON DEPRESSED	3-290

Troubleshooting Symptom Index (Cont)

Malfunction Number	Malfunction	Troubleshooting Procedure Page
HD45 HAMMER DRILL (SEE)		
108.	HAMMER DRILL WILL NOT OPERATE	3-292
109.	HAMMER DRILL OVEHEATS.	3-293
110.	HAMMER DRILL OPERATES SLOWLY OR INEFFECTIVELY	3-293
IMPACT WRENCH (HMMH)		
111.	IMPACT WRENCH PERFORMS POORLY OR HAS LOW IMPACT	3-294
112.	IMPACT WRENCH OVERHEATS	3-294
113.	OIL LEAKS AT HAMMER CASE	3-294
114.	IMPACT WRENCH WILL NOT OPERATE	3-295
115.	IMPACT WRENCH WILL NOT OPERATE IN ONE DIRECTION ONLY	3-295
BR67 PAVEMENT BREAKER (SEE)		
116.	PAVEMENT BREAKER WILL NOT OPERATE	3-296
117.	PAVEMENT BREAKER WILL NOT OPERATE EFFECTIVELY	3-296
118.	PAVEMENT BREAKER OVERHEATS	3-296
CHAIN SAW (SEE)		
119.	CHAIN SAW WILL NOT OPERATE	3-296
120.	CHAIN SAW CUTS SLOWLY OR NOT AT ALL	3-296
121.	BAR TURNS COLOR	3-297
122.	CHAIN SAW OVERHEATS	3-297
BACKHOE (SEE)		
123.	ALL BACKHOE FUNCTIONS SLUGGISH	3-298
124.	BOOM CYLINDERDRIFTS	3-298
125.	BUCKET CYLINDERDRIFTS.	3-300
126.	DIPPER CYLINDERDRIFTS	3-302
127.	SWING CYLINDER DRIFTS	3-303
128.	STABILIZER CYLINDERDRIFTS	3-305
129.	BACKHOE SHOWS ERRATIC MOVEMENTS WHILE SWINGING	3-306
130.	BOOM LOWERS TOO FAST.	3-308
CRANE (HMMH)		
131.	CRANE CONTROLS WILL NOT RESPOND	3-309
132.	CRANE OPERATION SLOWS DOWN	3-309
133.	CRANE OPERATION UNUSUALLY NOISY.	3-310
134.	VERTICAL OUTRIGGER CYLINDER YIELDS OR DRIFTS	3-310
135.	HORIZONTAL OUTRIGGER CYLINDER WILL NOT RETRACT	3-310
136.	INNER BOOM LIFT CYLINDER DRIFTS	3-311
137.	OUTER BOOM CYLINDER DRIFTS WHEN LOADED AND CONTROLS. IN NEUTRAL	3-314

Troubleshooting Symptom Index (Cont)

Malfunction Number	Malfunction	Troubleshooting Procedure Page
FRONT LOADER (SEE)		
138.	FRONT LOADER OPERATES SLOW	3-315
139.	FRONT LOADER WILL NOT RAISE OR LOWER	3-316
140.	FRONT LOADER WILL NOT LOWER USING BUCKET SWITCH	3-316
141.	FRONT LOADER WILL NOT RAISE USING BUCKET SWITCH	3-317
142.	LOADER BOOM CYLINDER DRIFTS	3-317
143.	BUCKET ROLLBACK CYLINDER DRIFTS.	3-320
144.	LOAD DROPS WITH CONTROL VALVE IN NEUTRAL	3-322
145.	CONTROL VALVE STICKS OR WORKS HARD	3-322

Table 3-5. Troubleshooting

Malfunction	Test or Inspection	Corrective Action
-------------	--------------------	-------------------

ENGINE

WARNING

Before starting engine, make sure all personnel are clear of engine. Failure to do so could result in injury to personnel.

1. ENGINE WILL NOT CRANK.

NOTE

Refer to wiring diagram (page 3-77) for all wiring repair steps.

Step 1. Check for loose electrical connections on battery and starter.

- If electrical connections are loose, tighten connections.
- If electrical connections are tight, go to step 2.

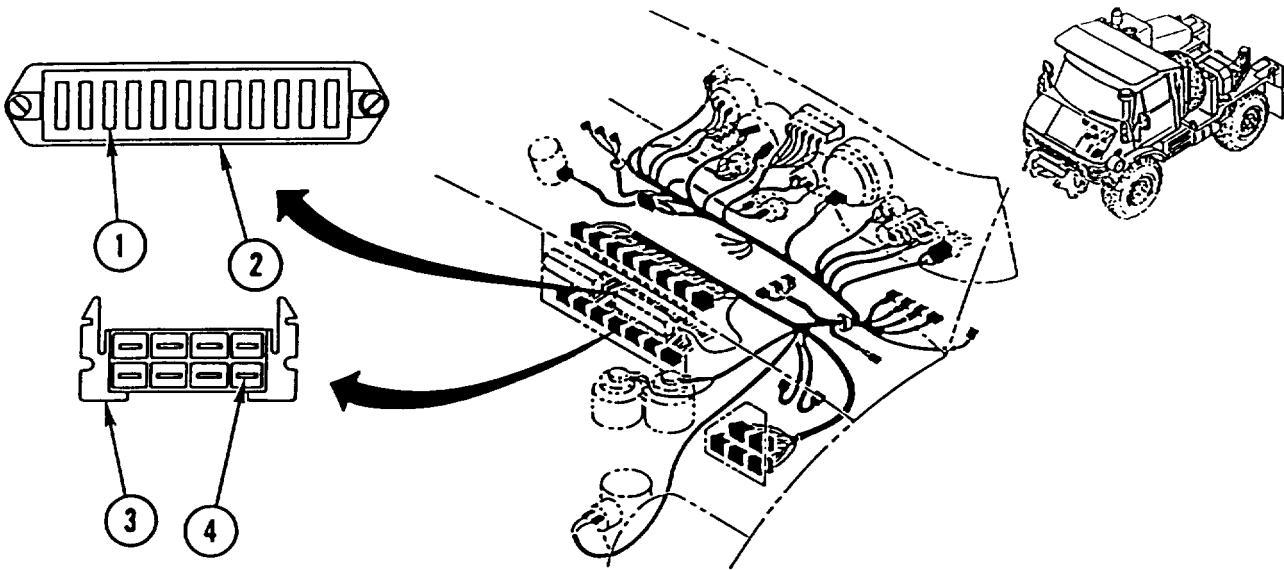

Step 2. Check condition of fuse No. 3 (1), fuse box 1 (2).

- If fuse No. 3 is blown, replace fuse.
- If fuse No. 3 is good, go to step 3.

Table 3-5. Troubleshooting (Cont)

Malfunction	Test or Inspection	Corrective Action
-------------	--------------------	-------------------

ENGINE (CONT)

NOTE

If STE/ICE-R CI Engine GO-NO GO Chain does not diagnose cause of problem, return to this troubleshooting table.

Step 3. Perform STE/ICE-R CI Engine GO-NO GO Chain test procedures in the DCA diagnostic mode.

- If malfunction is found, refer to List of Tasks (page iii) or Alphabetical Index (page Index-1) and repair or replace damaged or faulty components.
- If malfunction is not found, go to step 4.

Step 4. Disconnect connector D (3) and check for +24 VDC between wire 11 (4) and ground.

- If +24 VDC is not present, repair wiring 11 between starter and connector D.
- If +24 VDC is present, reconnect connector D and go to step 5.

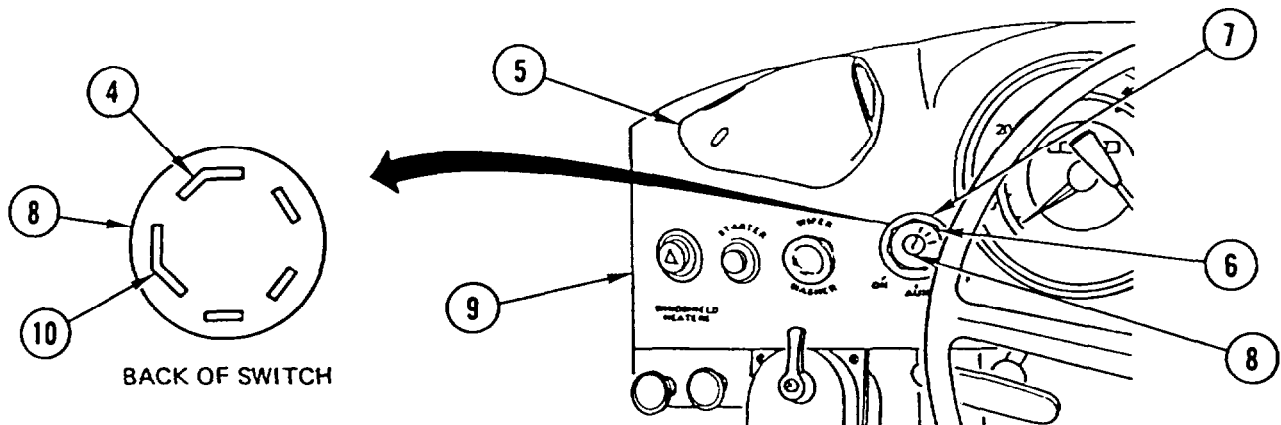

Step 5. Remove defrost vent (5), nut (6), and washer (7) and pull ignition switch (8) out through opening in dashboard (9).

Step 6. Check for +24 VDC between wire 11 (4) and ground at ignition switch (8).

- If +24 VDC is not present, repair wiring 11 between connector D and ignition switch.
- If +24 VDC is present, go to step 7.

Step 7. Check for +24 VDC between wire 12 (10) and ground at ignition switch (8).

- If +24 VDC is not present, replace ignition switch (page 4-131).
- If +24 VDC is present, go to step 8.

Table 3-5. Troubleshooting (Cont)

Malfunction	Test or Inspection	Corrective Action
-------------	--------------------	-------------------

ENGINE (CONT)

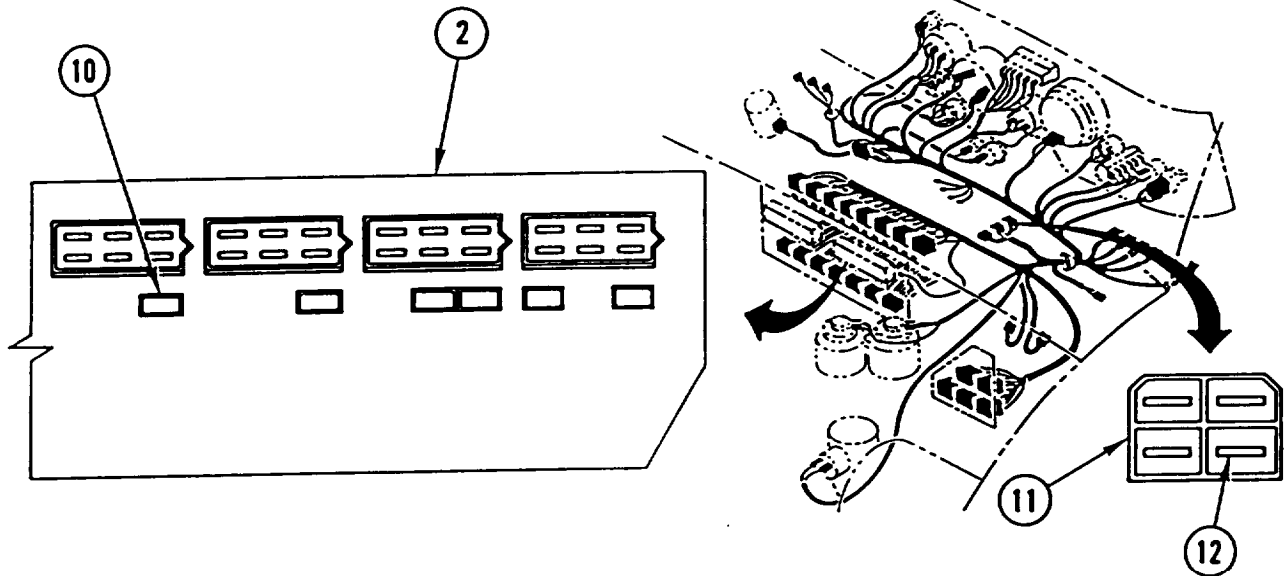

Step 8. Check for +24 VDC between wire 12 (10) and ground at fuse box 1 (2).

- If +24 VDC is not present, repair wiring 12 between fuse box 1 and ignition switch.
- If +24 VDC is present, go to step 9.

Step 9. Disconnect connector J (11) and check for +24 VDC between wire 214 (12) and ground.

- If +24 VDC is not present, repair wiring 214 between connector J and fuse box 1.
- If +24 VDC is present, reconnect connector J and go to step 10.

Table 3-5. Troubleshooting (Cont)

Malfunction	Test or Inspection	Corrective Action
-------------	--------------------	-------------------

ENGINE (CONT)

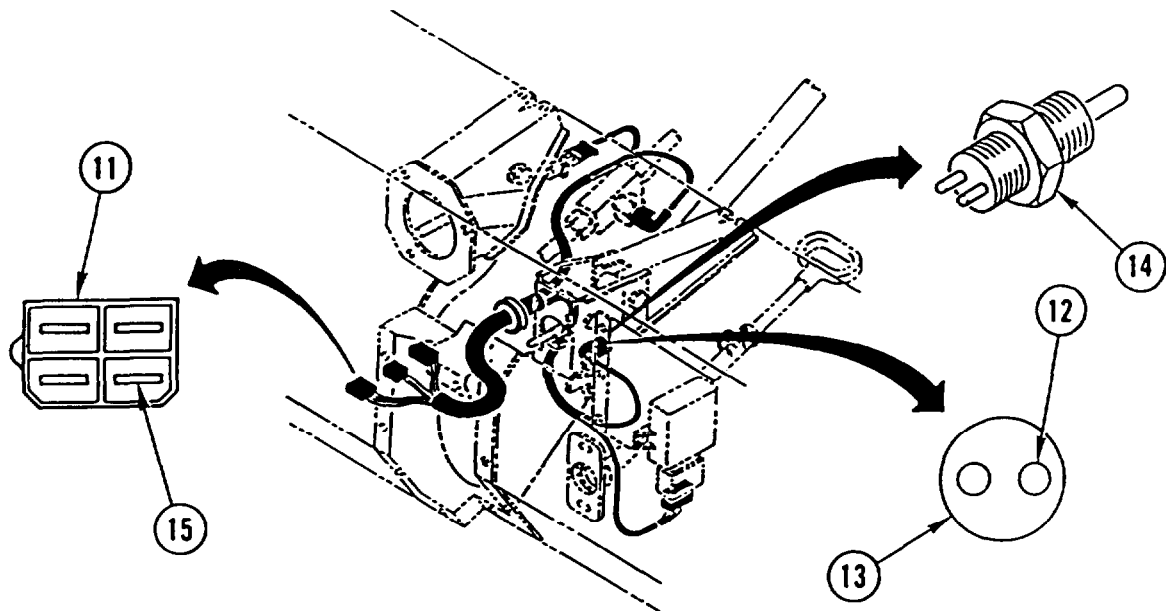

- Step 10. Disconnect engine start switch connector (13) and check for +24 VDC between wire 214 (12) and ground.
- If +24 VDC is not present, repair wiring 214 between engine start switch and connector J.
 - If +24 VDC is present, go to step 11.
- Step 11. With engine start switch connector (13) disconnected and engine start switch (14) depressed, check for continuity across engine start switch.
- If there is no continuity, replace engine start switch (page 4-199).
 - If there is continuity, reconnect engine start switch connector and go to step 12.
- Step 12. Disconnect connector J (11). With engine start switch depressed, check for +24 VDC between wire 215 (15) and ground.
- If +24 VDC is not present, repair wiring 215 between engine start switch and connector J.
 - If +24 VDC is present, reconnect connector J and go to step 13.

Table 3-5. Troubleshooting (Cont)

Malfunction	Test or Inspection	Corrective Action
-------------	--------------------	-------------------

ENGINE (CONT)

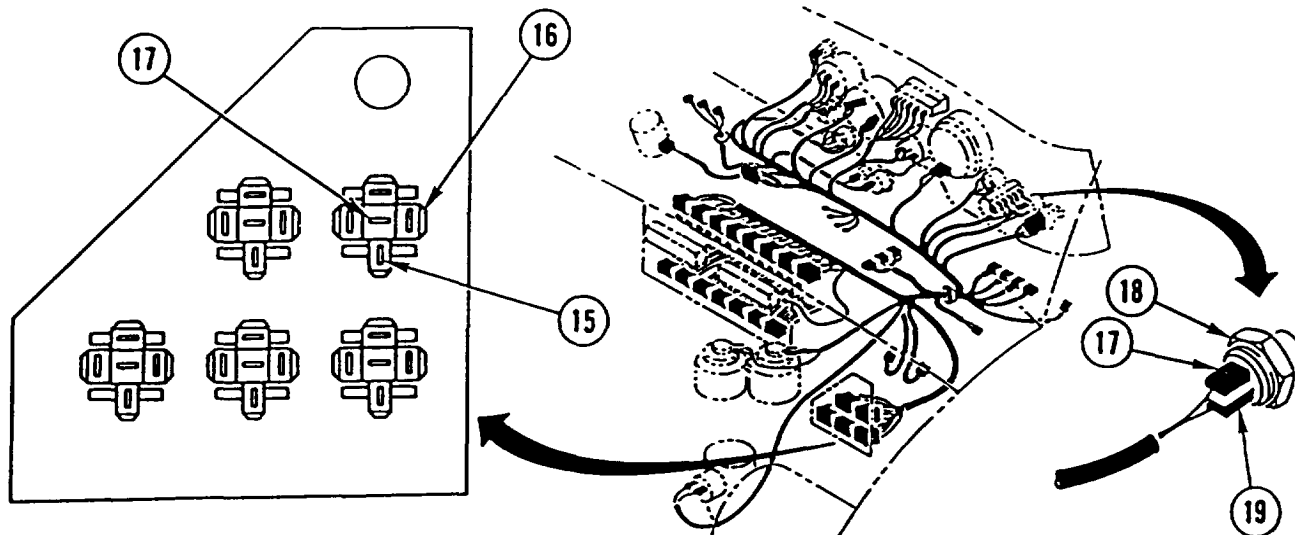

- Step 13. With engine start switch depressed, check for +24 VDC between wire 215 (15) and ground at relay K2 (16).
- If +24 VDC is not present, repair wiring 215 between connector J and relay K2.
 - If +24 VDC is present, go to step 14.
- Step 14. With engine start switch depressed, check for +24 VDC between wire 211 (17) and ground at relay K2 (16).
- If +24 VDC is not present, replace relay K2.
 - If +24 VDC is present, go to step 15.
- Step 15. With engine start switch depressed, check for +24 VDC between wire 211 (17) and ground at starter switch (18).
- If +24 VDC is not present, repair wiring 211 between relay K2 and starter switch.
 - If +24 VDC is present, go to step 16.
- Step 16. With engine start switch and starter switch (18) depressed, check for +24 VDC between wire 212 (19) and ground at starter switch.
- If +24 VDC is not present, replace starter switch (page 4-133).
 - If +24 VDC is present, go to step 17.

Table 3-5. Troubleshooting (Cont)

Malfunction	Test or Inspection	Corrective Action
-------------	--------------------	-------------------

ENGINE (CONT)

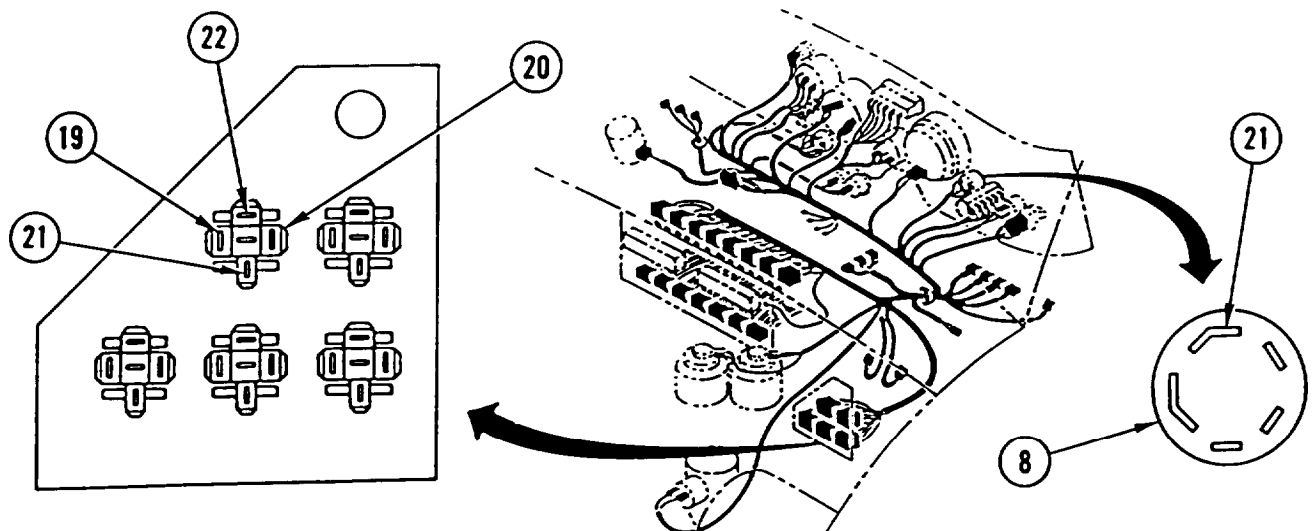

Step 17. With engine start switch and starter switch depressed, check for +24 VDC between wire 212 (19) and ground at relay K1 (20).

- If +24 VDC is not present, repair wiring 212 between starter switch and relay K1.
- If +24 VDC is present, go to step 18.

Step 18. Check for +24 VDC between wire 132 (21) and ground at ignition switch (8).

- If +24 VDC is not present, replace ignition switch (page 4-131).
- If +24 VDC is present, go to step 19.

Step 19. Check for +24 VDC between wire 132 (21) and ground at relay K1 (20).

- If +24 VDC is not present, repair wiring 132 between ignition switch and relay K1.
- If +24 VDC is present, go to step 20.

Step 20. With engine start switch and starter switch depressed, check for +24 VDC between wire 213 (22) and ground at relay K1 (20).

- If +24 VDC is not present, replace relay K1.
- If +24 VDC is present, go to step 21.

Table 3-5. Troubleshooting (Cont)

Malfunction	Test or Inspection	Corrective Action
-------------	--------------------	-------------------

ENGINE (CONT)

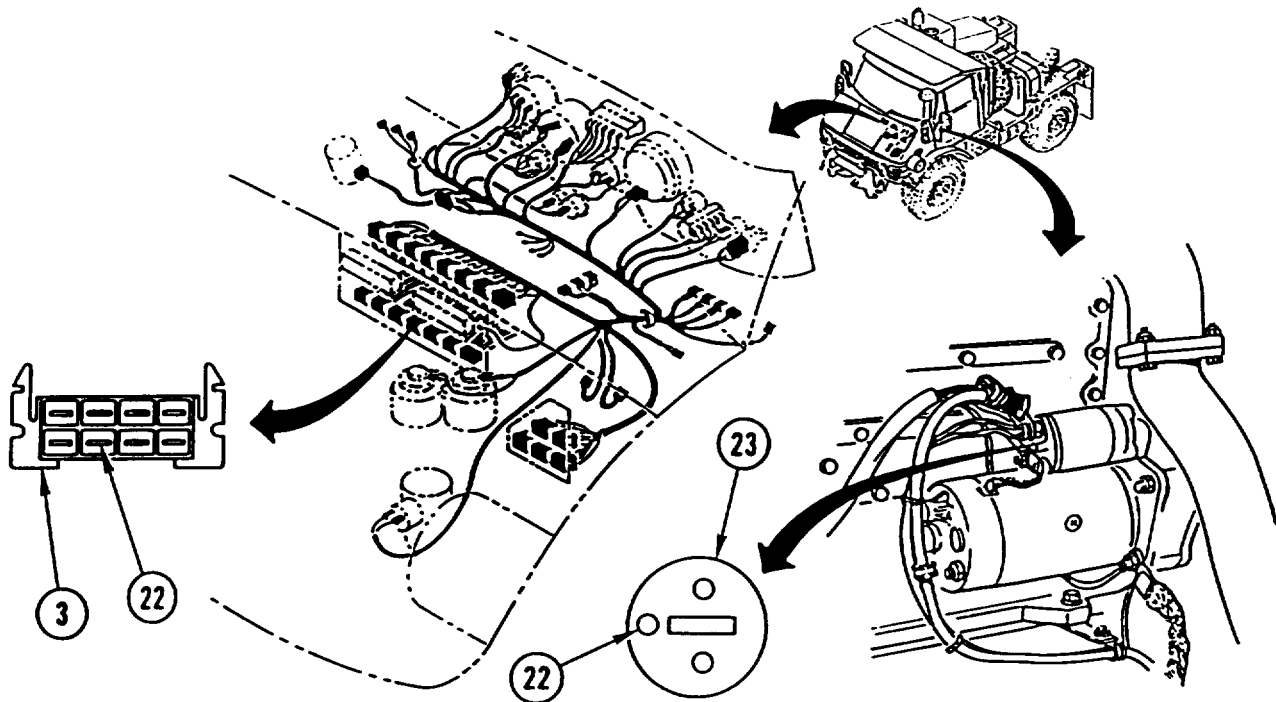

Step 21. Disconnect connector D (3). With engine start switch and starter switch depressed, check for +24 VDC between wire 213 (22) and ground.

- If +24 VDC is not present, repair wiring 213 between connector D and relay K1.
- If +24 VDC is present, reconnect connector D and go to step 22.

Step 22. With engine start switch and starter switch depressed, check for +24 VDC between wire 213 (22) and ground at starter (23).

NOTE

If starter is determined to be defective, perform Malfunction 2 prior to replacing starter.

- If +24 VDC is present, replace starter (page 4-117).
- If +24 VDC is not present, repair wiring 213 between starter and connector D.

Table 3-5. Troubleshooting (Cont)

Malfunction	Test or Inspection	Corrective Action
-------------	--------------------	-------------------

ENGINE (CONT)

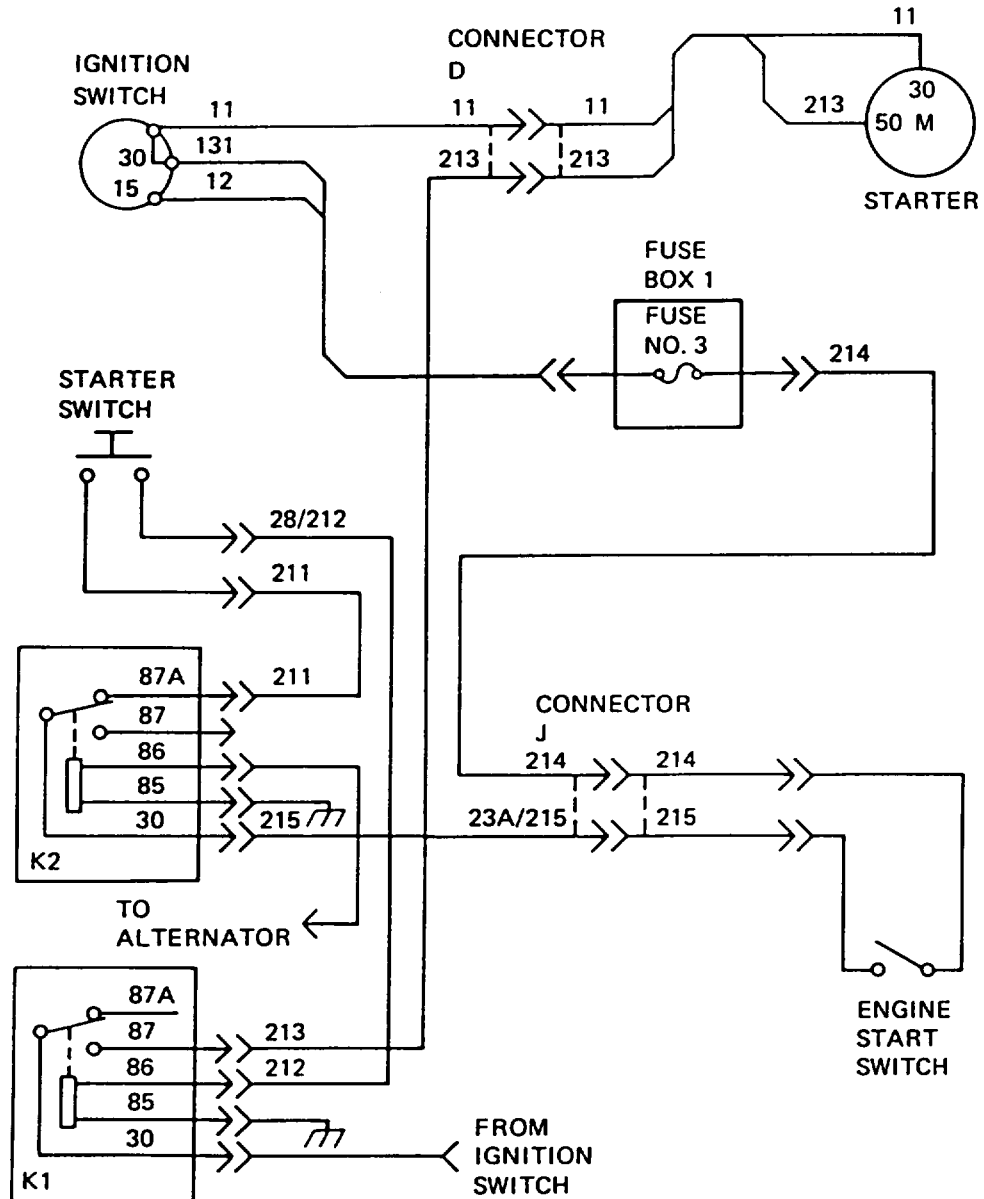
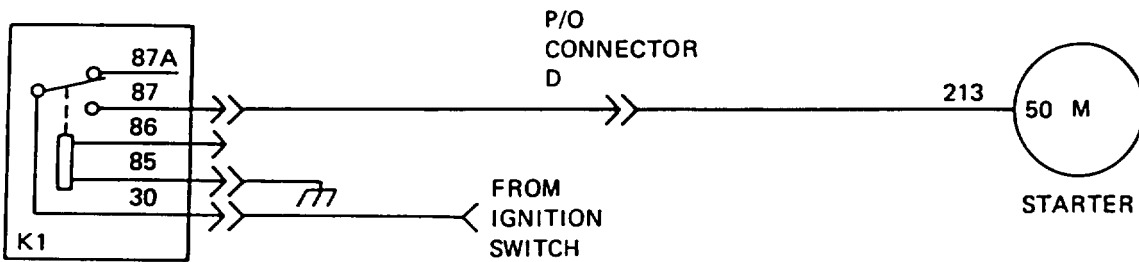
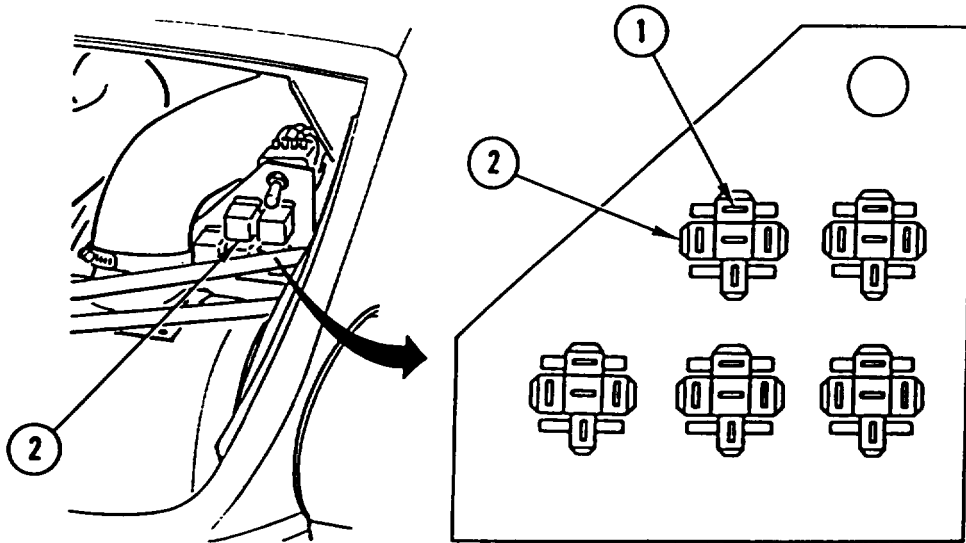

Table 3-5. Troubleshooting (Cont)

Malfunction	Test or Inspection	Corrective Action
-------------	--------------------	-------------------

ENGINE (CONT)

2. STARTER CONTINUES TO RUN AFTER STARTER SWITCH RELEASED.



Check for +24 VDC between wire 213 (1) and ground at relay K1 (2).

- If +24 VDC is not present, replace starter solenoid (page 4-119).
- If +24 VDC is present, replace relay K1.

Table 3-5. Troubleshooting (Cont)

Malfunction	Test or Inspection	Corrective Action
-------------	--------------------	-------------------

ENGINE (CONT)

3. ENGINE CRANKS SLOWLY.

Step 1. Check for loose and dirty battery connections.

- If battery connections are loose or dirty, tighten or clean connections.
- If battery connections are not loose or dirty, go to step 2.

NOTE

If STE/ICE-R CI Engine GO-NO GO Chain does not diagnose cause of problem, return to this troubleshooting table.

Step 2. Perform STE/ICE-R CI Engine GO-NO GO Chain test procedures in the DCA diagnostic mode.

- If malfunction is found, refer to List of Tasks (page iii) or Alphabetical Index (page Index-1) and repair or replace damaged or faulty components.
- If malfunction is not found, notify direct support maintenance.

4. ENGINE CRANKS BUT WILL NOT START OR HARD TO START.

Step 1. Check if air cleaner restrictor indicator light is lit.

- If indicator light is lit, replace air cleaner element (page 4-35).
- If indicator light is not lit, go to step 2.

Step 2. Check for smoke from exhaust while cranking engine.

- If there is smoke while cranking engine, go to step 5.
- If there is no smoke while cranking engine, go to step 3.

WARNING

Diesel fuel is flammable. Do not perform this procedure near fire, flame, or sparks. Injury or death to personnel could result.

Step 3. Check for clogged fuel cap (vent).

- If fuel cap is clogged, clean vent or replace fuel cap (page 4-47).
- If fuel cap is not clogged, go to step 4.

Table 3-5. Troubleshooting (Cont)

Malfunction	Test or Inspection	Corrective Action
-------------	--------------------	-------------------

ENGINE (CONT)

Step 4. Check for water/contamination in fuel tank.

- If there is water/contamination in fuel tank, drain fuel tank until only fuel drains out (page 4-40).
- If there is no water/contamination in fuel tank, go to step 5.

Step 5. Check for air leaks and damaged fuel lines.

- If there are air leaks or damaged fuel lines, tighten loose connections or replace fuel lines (pages 4-25, 4-44).
- If there are no air leaks or damaged fuel lines, go to step 6.

NOTE

If STE/ICE-R CI Engine GO-NO GO Chain does not diagnose cause of problem, return to this troubleshooting table.

Step 6. Perform STE/ICE-R CI Engine GO-NO GO Chain test procedures in the DCA diagnostic mode.

- If malfunction is found, refer to List of Tasks (page iii) or Alphabeticailindex (page Index-1) and repair or replace damaged or faulty components.
- If malfunction is not found, notify direct support maintenance.

5. ENGINE RUNS ROUGH OR LACKS POWER.

Step 1. Check If air cleaner restrictor indicator light is lit.

- If indicator light is lit, replace air cleaner element (page 4-35).
- If indicator light is not lit, go to step 2.

Step 2. Check for clogged exhaust system.

- If exhaust system is clogged, replace components as required (pages 4-80, 4-81, 4-85).
- If exhaust system is not clogged, go to step 3.

Table 3-5. Troubleshooting (Cont)

Malfunction	Test or Inspection	Corrective Action
-------------	--------------------	-------------------

ENGINE (CONT)

WARNING

Diesel fuel is flammable. Do not perform this procedure near fire, flame, or sparks. Injury or death to personnel could result.

Step 3. Check for clogged fuel cap (vent).

- If fuel cap is clogged, clean vent or replace fuel cap (page 4-47).
- If fuel cap is not clogged, go to step 4.

Step 4. Check for water/contamination in fuel tank.

- If there is water/contamination in fuel tank, drain fuel tank until only fuel drains out (page 4-40).
- If there is no water/contamination in fuel tank, go to step 5.

Step 5. Check for air leaks and damaged fuel lines.

- If there are air leaks or damaged fuel lines, tighten loose connections or replace fuel lines (pages 4-25, 4-44).
- If there are no air leaks or damaged fuel lines, go to step 6.

NOTE

If STE/ICE-R CI Engine GO-NO GO Chain does not diagnose cause of problem, return to this troubleshooting table.

Step 6. Perform STE/ICE-R CI Engine GO-NO GO Chain test procedures in the DCA diagnostic mode.

- If malfunction is found, refer to List of Tasks (page iii) or Alphabetical Index (page Index-1) and repair or replace damaged or faulty components.
- If malfunction is not found, go to step 7.

Step 7. Check valve adjustment (page 4-5).

- If valves require adjustment, adjust valves to proper tolerances (page 4-5).
- If valves do not require adjustment, notify direct support maintenance.

Table 3-5. Troubleshooting (Cont)

Malfunction	Test or Inspection	Corrective Action
-------------	--------------------	-------------------

ENGINE (CONT)

6. FUEL CONSUMPTION EXCESSIVE.

Step 1. Check if air cleaner restrictor indicator light is lit.

- If indicator light is lit, replace air cleaner element (page 4-35).
- If indicator light is not lit, go to step 2.

WARNING

Diesel fuel is flammable. Do not perform this procedure near fire, flame, or sparks. Injury or death to personnel could result.

Step 2. Check for loose and damaged fuel lines.

- If fuel lines are loose or damaged, lighten loose connections or replace fuel lines (pages 4-25, 4-44).
- If fuel lines are not loose or damaged, go to step 3.

Step 3. Check for clogged exhaust system.

- If exhaust system is clogged, replace components as required (pages 4-80, 4-81, 4-85).
- If exhaust system is not clogged, go to step 4.

NOTE

If STE/ICE-R CI Engine GO-NO GO Chain does not diagnose cause of problem, return to this troubleshooting table.

Step 4. Perform STE/ICE-R CI Engine GO-NO GO Chain test procedures in the DCA diagnostic mode.

- If malfunction is found, refer to List of Tasks (page iii) or Alphabetical Index (page Index-1) and repair or replace damaged or faulty components.
- If malfunction is not found, notify direct support maintenance.

7. DECELERATION SLOW OR UNEVEN.

Check accelerator linkage for proper adjustment and operation.

- If accelerator linkage is not adjusted or operating properly, adjust accelerator linkage (page 4-68).
- If accelerator linkage is adjusted and operating properly, notify direct support maintenance.

Table 3-5. Troubleshooting (Cont)

Malfunction	Test or Inspection	Corrective Action
-------------	--------------------	-------------------

ENGINE (CONT)

8. IDLE SPEED ERRATIC.

WARNING

Diesel fuel is flammable. Do not perform this procedure near fire, flame, or sparks. Injury or death to personnel could result.

Step 1. Check for air leaks and damaged fuel lines.

- If there are air leaks or damaged fuel lines, tighten loose connections or replace fuel lines (pages 4-25, 4-44).
- If there are no air leaks or damaged fuel lines, go to step 2.

NOTE

If STE/ICE-R CI Engine GO-NO GO Chain does not diagnose cause of problem, return to this troubleshooting table.

Step 2. Perform STE/ICE-R CI Engine GO-NO GO Chain test procedures in the DCA diagnostic mode.

- If malfunction is found, refer to List of Tasks (page iii) or Alphabetical Index (page Index-1) and repair or replace damaged or faulty components.
- If malfunction is not found, notify direct support maintenance.

9. ENGINE KNOCKS WHEN COLD.

Step 1. Check for low engine oil level.

- If engine oil level is low, add oil (LO 5-2420-224-12).
- If engine oil level is not low, go to step 2.

Step 2. Check for stuck fuel injector nozzles by fully depressing accelerator several times to release needles.

- If problem continues, notify direct support maintenance.

10. OIL PRESSURE GAGE READS LOW OR NO OIL PRESSURE.

Step 1. Check for low engine oil level.

- If engine oil level is low, add oil (LO 5-2420-224-12).
- If engine oil level is not low, go to step 2.

Table 3-5. Troubleshooting (Cont)

Malfunction

Test or Inspection

Corrective Action

ENGINE (CONT)

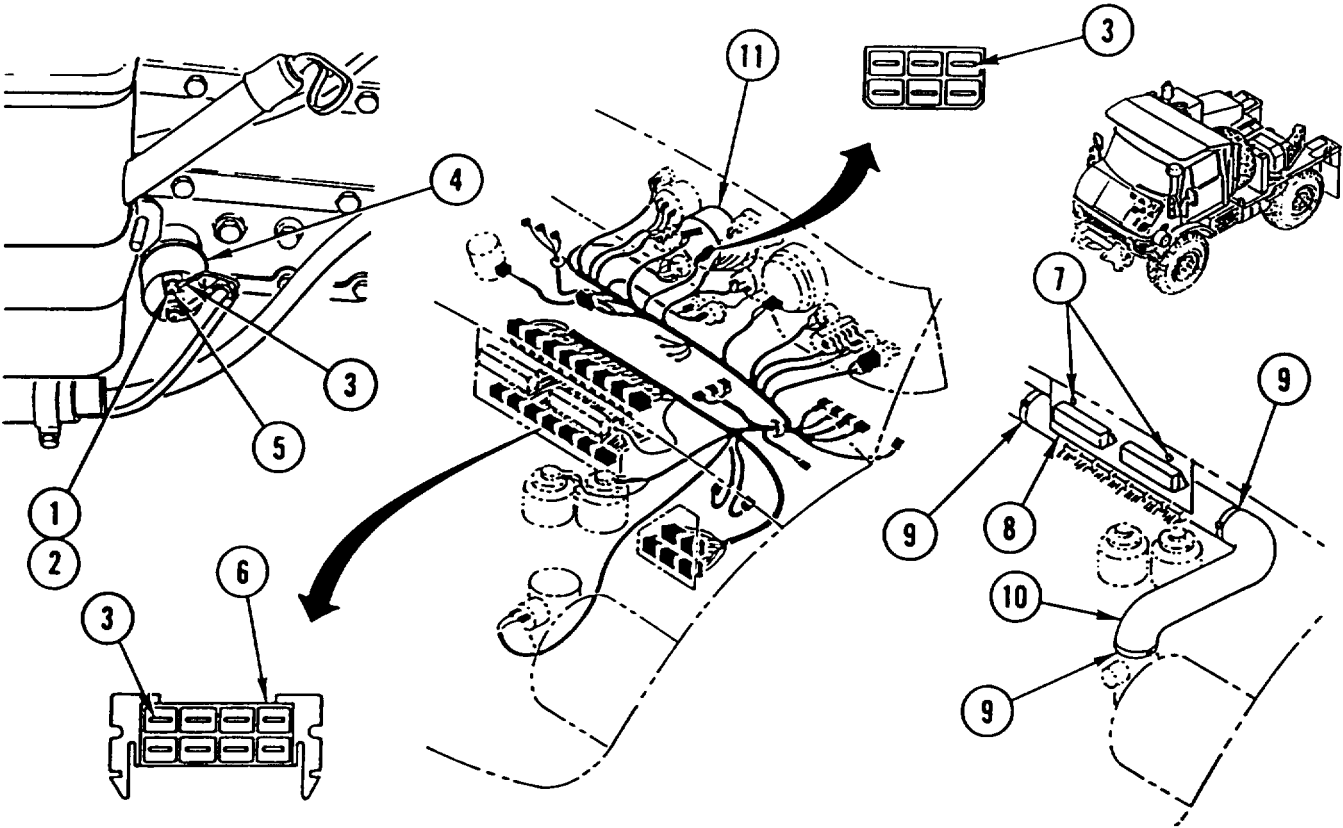

Step 2. Remove nut (1) and lock washer (2) and disconnect wire 31P (3) from oil pressure sender (4). Check for resistance between terminal (5) and casing of oil pressure sender.

- If resistance is not present, replace oil pressure sender (page 4-202).
- If resistance is present, go to step 3.

Step 3. With wire 31P (3) disconnected from oil pressure sender (4), check for +24 VDC between wire 31P and ground at oil pressure sender.

- If +24 VDC is present, notify direct support maintenance.
- If +24 VDC is not present, go to step 4.

Table 3-5. Troubleshooting (Cont)

Malfunction	Test or Inspection	Corrective Action
ENGINE (CONT)		
	Step 4. With wire 31P (3) disconnected from oil pressure sender, check for +24 VDC between wire 31P and ground at connector D (6).	<ul style="list-style-type: none"> • If +24 VDC is present, repair wiring 31P between connector D and oil pressure sender. • If +24 VDC is not present, go to step 5.
	Step 5. Loosen two captive screws (7) and pull bracket (8) out enough to gain access to area behind bracket.	
	Step 6. Remove two clamps (9) and pipe assembly (10).	
	Step 7. With wire 31P (3) disconnected from oil pressure sender, check for +24 VDC between wire 31P and ground at indicator (gauge) (11).	<ul style="list-style-type: none"> • If +24 VDC is not present, reconnect wire 31P at oil pressure sender and replace oil pressure gage (page 4-124). • If +24 VDC is present, reconnect wire 31P at oil pressure sender and repair wiring 31P between indicator (gauge) and connector D.

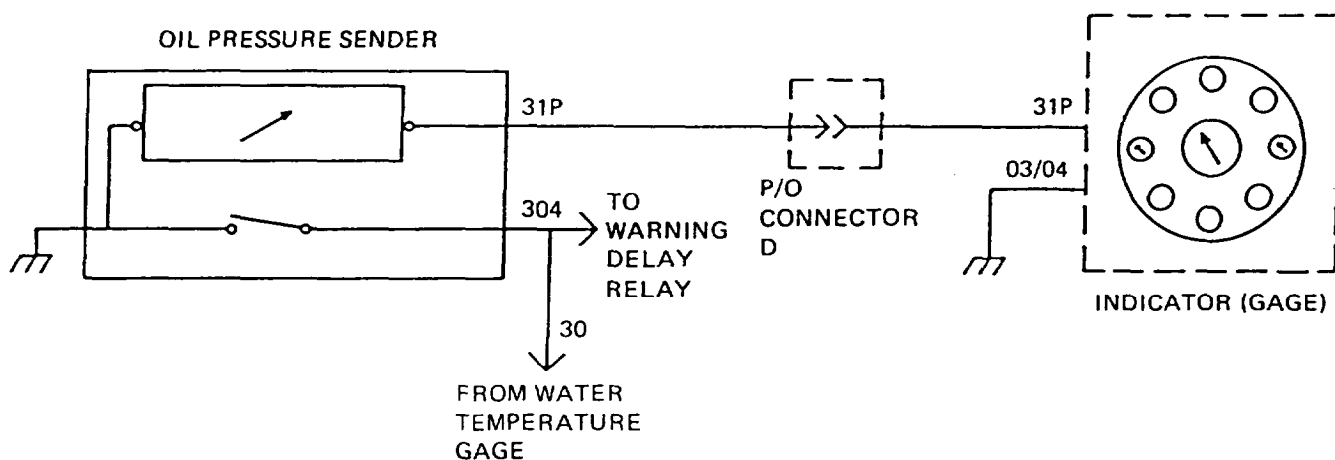

11. ENGINE USES TOO MUCH OIL.

Step 1. Check for loose and damaged oil hose.

- If oil hose is loose or damaged, tighten loose connections or replace oil hose (page 4-9).
- If oil hose is not loose or damaged, go to step 2.

Table 3-5. Troubleshooting (Cont)

Malfunction	Test or Inspection	Corrective Action
--------------------	---------------------------	--------------------------

ENGINE (CONT)

Step 2. Check for blue exhaust smoke.

- If there is blue exhaust smoke, replace valve cover gasket (page 4-3). If condition continues, notify direct support maintenance.
- If there is no blue exhaust smoke, notify direct support maintenance.

AIR INTAKE SYSTEM

12. AIR CLEANER RESTRICTOR INDICATOR LIGHT LIGHTS.

Step 1. Check for dirty air cleaner filters.

- If air cleaner filters are dirty, replace filters (page 4-35).
- If air cleaner filters are not dirty, go to step 2.

Step 2. Check for dirty and clogged vertical intake screen.

- If vertical intake screen is not dirty or clogged, replace air cleaner restrictor indicator switch (page 4-205).
- If vertical intake screen is dirty or clogged, clean screen.

EXHAUST SYSTEM

13. EXHAUST FUMES ENTER CAB.

Check for loose, damaged, and missing components in exhaust system.

- If components are loose, damaged, or missing, tighten loose connections or replace components (pages 4-80, 4-81, 4-85).
- If components are not loose, damaged, or missing, notify direct support maintenance.

14. EXHAUST NOISE EXCESSIVE.

Check for loose, damaged, and missing components in exhaust system.

- If components are loose, damaged, or missing, tighten loose connections or replace components (pages 4-80, 4-81, 4-85).
- If components are not loose, damaged, or missing, replace muffler (4-80).

Table 3-5. Troubleshooting (Cont)

Malfunction	Test or Inspection	Corrective Action
COOLING SYSTEM		
15. LOSS OF ENGINE COOLANT.	Perform cooling system test (page 4-89).	
16. ENGINE OVERHEATS.		
	Step 1. Check for low coolant level in radiator expansion tank.	<ul style="list-style-type: none"> • If coolant level in radiator expansion tank is low, add coolant as required (TM 5-2420-224-10). • If coolant level in radiator expansion tank is not low, go to step 2.
	Step 2. Check for leaking and damaged coolant hoses.	<ul style="list-style-type: none"> • If coolant hoses are leaking or damaged, tighten loose connections or replace coolant hoses (page 4-98). • If coolant hoses are not leaking or damaged, go to step 3.
	Step 3. Check for loose, worn, and missing fan belt.	<ul style="list-style-type: none"> • If fan belt is loose, worn, or missing, adjust or replace fan belt (page 4-106). • If fan belt is not loose, worn, or missing, go to step 4.
	Step 4. Check for clogged radiator cooling core by draining coolant from radiator.	<ul style="list-style-type: none"> • If coolant drains properly, replace coolant thermostat (page 4-100). • If coolant does not drain properly, replace radiator (page 4-92).

Table 3-5. Troubleshooting (Cont)

Malfunction

Test or Inspection

Corrective Action

ELECTRICAL SYSTEM

WARNING

When replacing fuses, make sure only fuses of correct amperage are installed. Failure to do so could result in injury to personnel or damage to equipment.

NOTE

- Before starting troubleshooting, check for bad wire connections, blown fuses, and proper switch settings.
- During troubleshooting of circuits containing lamps, fuses, or relays, first check problem by replacing lamp, fuse, or relay with known good lamp, fuse, or relay. This may save time and effort.
- During troubleshooting, check all wiring in a circuit for damage (e.g., cuts, wear, bubbling, burning, etc.).
- Before performing voltage checks, make sure equipment is properly set up (e.g., to check for voltage at turn signal, make sure vehicle MASTER disconnect switch and ignition switch are ON and turn signal lever is switched to L or R position).

17. NO ELECTRICAL POWER.

NOTE

Refer to wiring diagram (page 3-90) for all wiring repair steps.

Step 1. Check batteries (TM 5-2420-220-10).

- If batteries are bad, charge (TM 5-2420-224-10) or replace (page 4-219) batteries.
- If batteries are good, go to step 2.

Step 2. Check for +24 VDC between positive battery terminal (1) and negative battery terminal (2) on batteries (3).

- If +24 VDC is not present, repair interbattery connect cable (4).
- If +24 VDC is present, go to step 3.

Step 3. Check for +24 VDC between positive battery cable (5) at frame positive stud (6) and ground at negative battery terminal (2).

- If +24 VDC is not present, repair positive battery cable.
- If +24 VDC is present, go to step 4.

Table 3-5. Troubleshooting (Cont)

Malfunction	Test or Inspection	Corrective Action
-------------	--------------------	-------------------

ELECTRICAL SYSTEM (CONT)

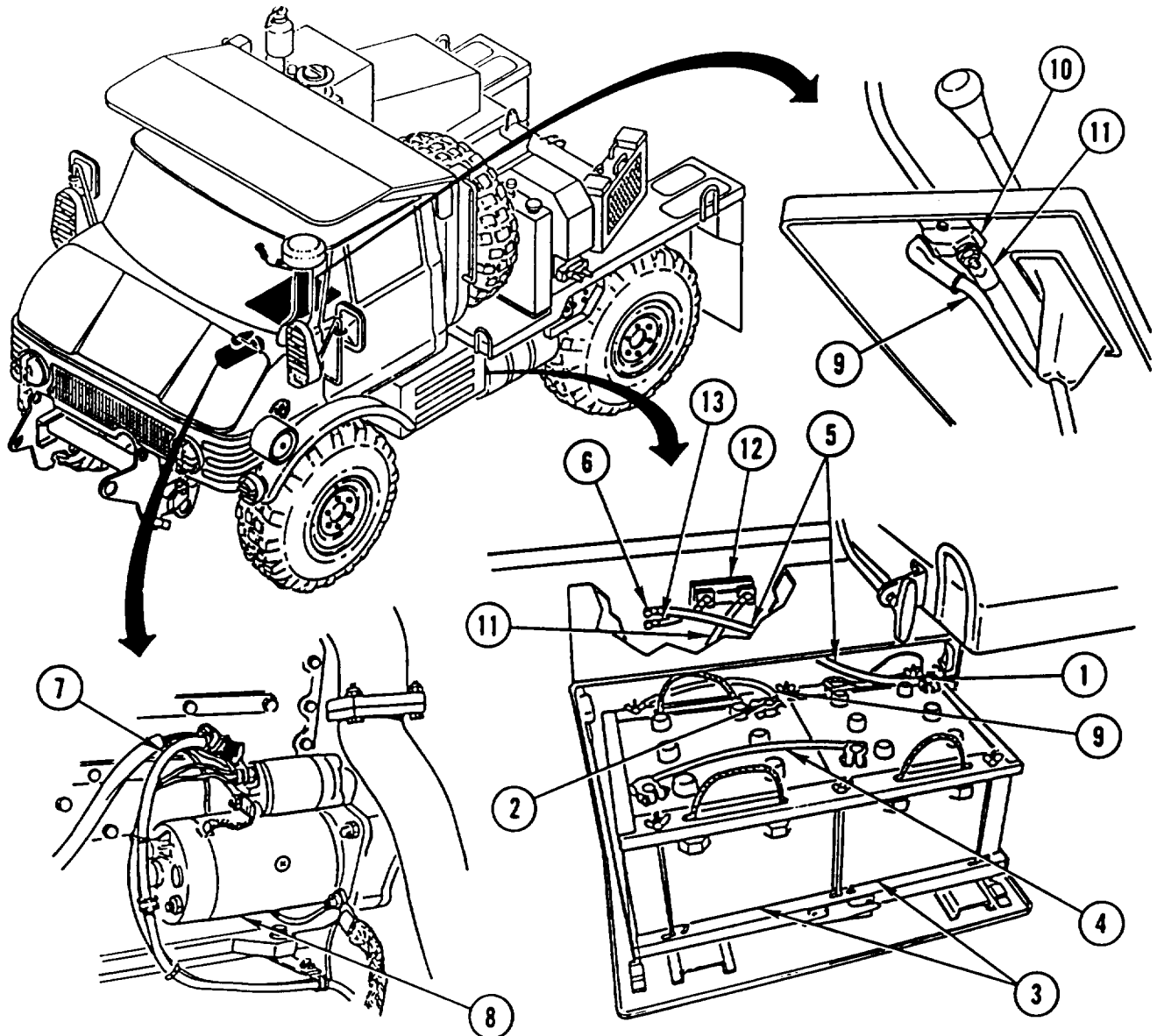

Step 4. Check for +24 VDC between positive starter cable (7) at starter (8) and ground at negative battery terminal (2).

- If +24 VDC is not present, repair positive starter cable.
- If +24 VDC is present, go to step 5.

Step 5. Tilt cab (page 4-418).

Table 3-5. Troubleshooting (Cont)

Malfunction	Test or Inspection	Corrective Action
-------------	--------------------	-------------------

ELECTRICAL SYSTEM (CONT)

- Step 6. Check for continuity of negative battery cable (9) between negative battery terminal (1) and vehicle MASTER disconnect switch (10).
- If there is no continuity, repair negative battery cable.
 - If there is continuity, go to step 7.
- Step 7. With vehicle MASTER disconnect switch (10) ON, check for continuity across vehicle MASTER disconnect switch.
- If there is no continuity, replace vehicle MAIN (MASTER) disconnect switch (page 4-171).
 - If there is continuity, go to step 8.
- Step 8. With vehicle MASTER disconnect switch (10) OFF, check for continuity of ground cable (11) between vehicle MASTER disconnect switch and STE/ICE-R shunt (12).
- If there is no continuity, repair ground cable.
 - If there is continuity, go to step 9.
- Step 9. With vehicle MASTER disconnect switch (10) OFF, check for continuity across STE/ICE-R shunt (12).
- If there is no continuity, replace STE/ICE-R shunt (page 4-213).
 - If there is continuity, repair ground cable (13).

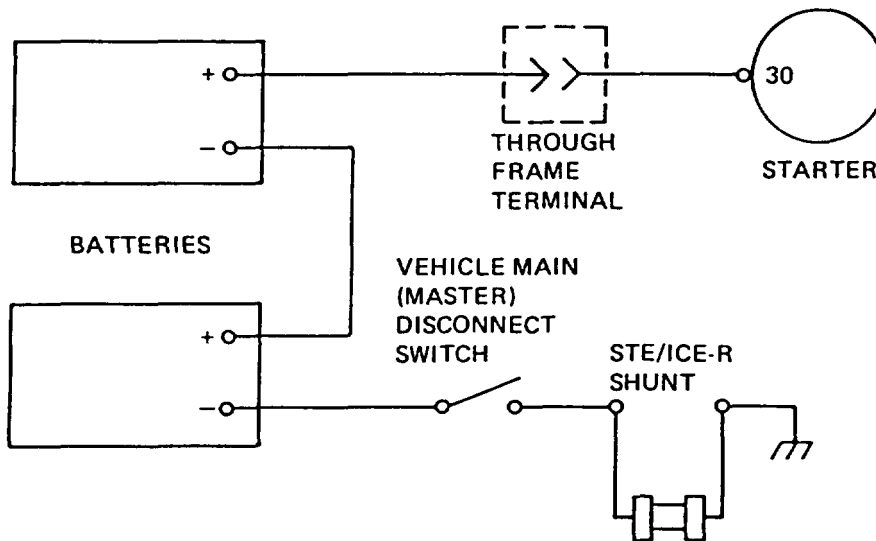

Table 3-5. Troubleshooting (Cont)

Malfunction	Test or Inspection	Corrective Action
-------------	--------------------	-------------------

ELECTRICAL SYSTEM (CONT)

18. RIGHT FRONT AUXILIARY HEADLIGHT LOW BEAM WILL NOT LIGHT.

NOTE

- Vehicle MASTER disconnect switch must be ON, master light switch set to SER DRIVE, horn, low beam/high beam switch set to LO, and auxiliary light control switch in up position. Failure to do so will cause erroneous results.
- Refer to wiring diagram (page 3-93) for all wiring repair steps.

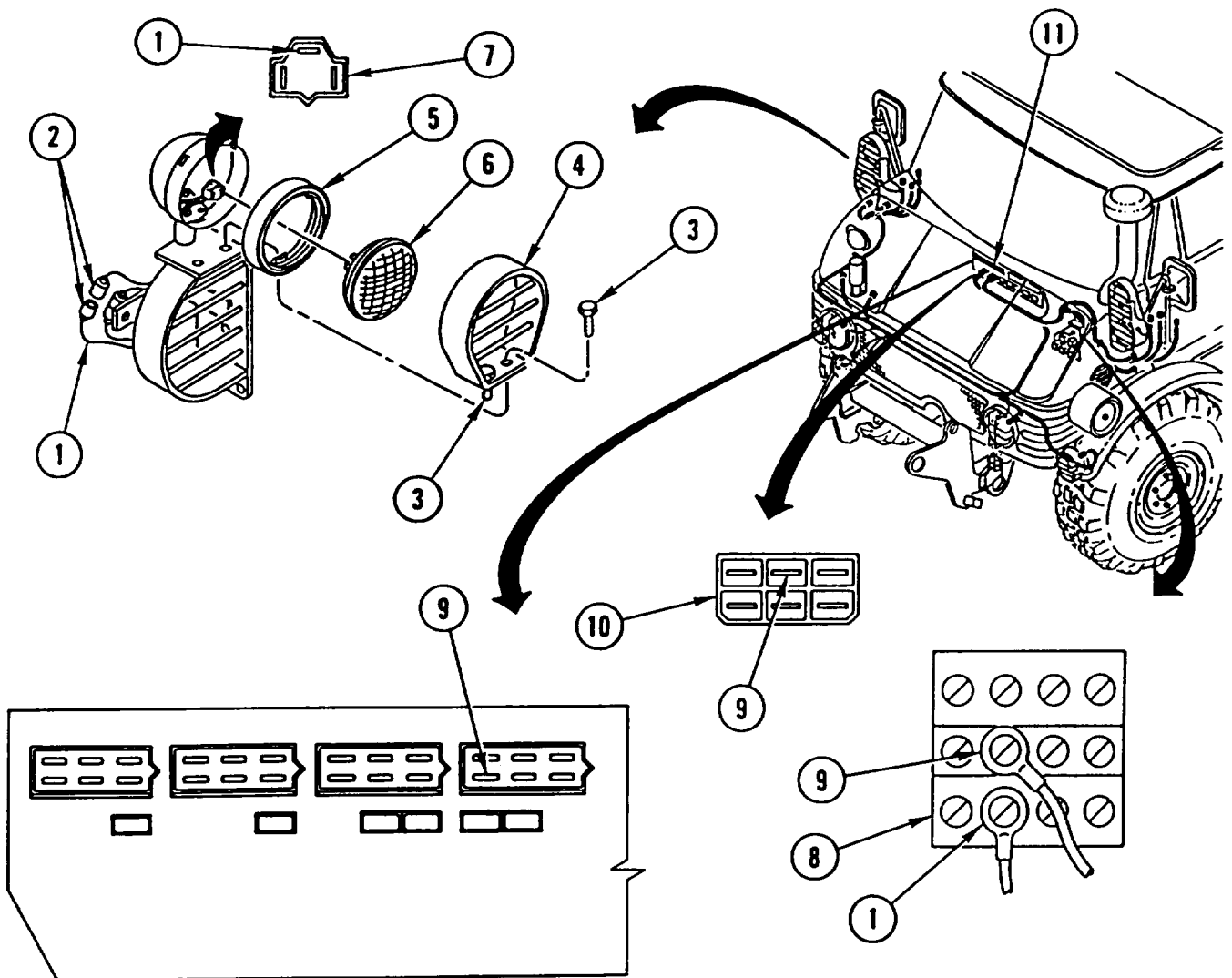

Table 3-5. Troubleshooting (Cont)

Malfunction	Test or Inspection	Corrective Action
ELECTRICAL SYSTEM (CONT)		
	Step 1. Check for +24 VDC between wire 42LR (1) and ground at auxiliary headlight connector (2).	<ul style="list-style-type: none"> • If +24 VDC is not present, go to step 4. • If +24 VDC is present, go to step 2.
	Step 2. Remove two bolts (3), lamp guard (4), mount (5), and lamp (6).	
	Step 3. Check for +24 VDC between wire 42LR (1) and ground at socket (7).	<ul style="list-style-type: none"> • If +24 VDC is present, replace lamp. • If +24 VDC is not present, repair wiring 42LR between socket and auxiliary headlight connector.
	Step 4. Check for +24 VDC between wire 42LR (1) and ground at auxiliary light control switch (8).	<ul style="list-style-type: none"> • If +24 VDC is present, repair wiring 42LR between auxiliary headlight connector and auxiliary light control switch. • If +24 VDC is not present, go to step 5.
	Step 5. Check for +24 VDC between wire 41LR (9) and ground at auxiliary light control switch (8).	<ul style="list-style-type: none"> • If +24 VDC is present, replace auxiliary light control switch (page 4-146). • If +24 VDC is not present, go to step 6.
	Step 6. Disconnect connector G (10) and check for +24 VDC between wire 41LR (9) and ground.	<ul style="list-style-type: none"> • If +24 VDC is present, repair wiring 41LR between connector G and auxiliary light control switch. • If +24 VDC is not present, reconnect connector G and go to step 7.
	Step 7. Check for +24 VDC between wire 41LR (9) and ground at fuse box 2 (11).	<ul style="list-style-type: none"> • If +24 VDC is present, repair wiring 41LR between fuse box 2 and connector G. • If +24 VDC is not present, repair wiring 41LR at fuse box 2.

Table 3-5. Troubleshooting (Cont)

Malfunction	Test or Inspection	Corrective Action
-------------	--------------------	-------------------

ELECTRICAL SYSTEM (CONT)

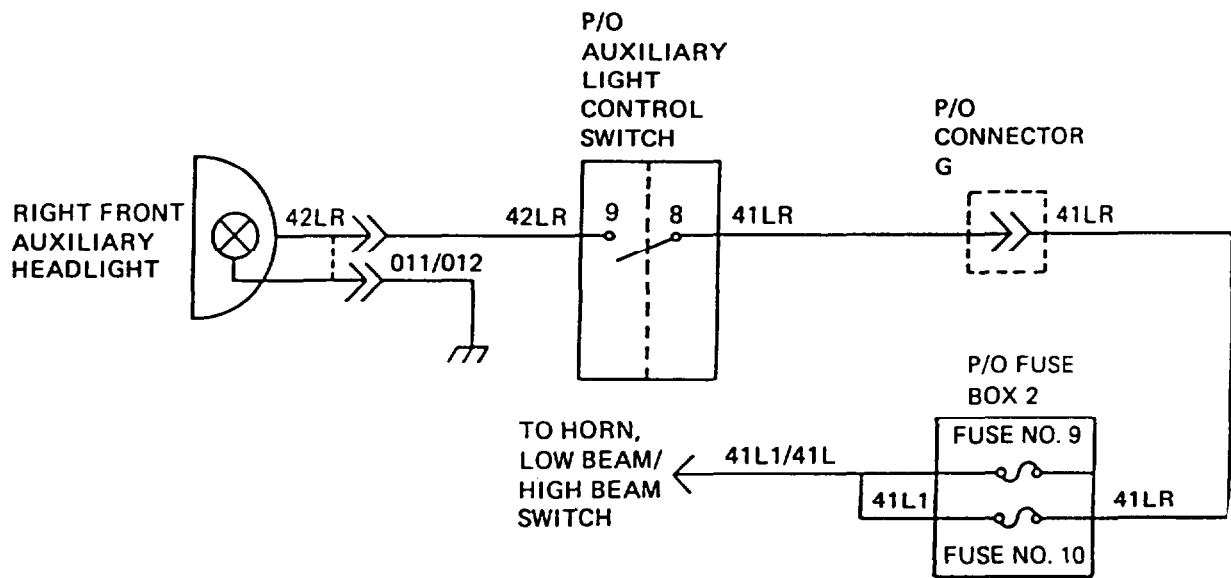

Table 3-5. Troubleshooting (Cont)

Malfunction

Test or Inspection

Corrective Action

ELECTRICAL SYSTEM (CONT)

19. RIGHT FRONT AUXILIARY HEADLIGHT HIGH BEAM WILL NOT LIGHT.

NOTE

- Vehicle MASTER disconnect switch must be ON, master light switch set to SER DRIVE, horn, low beam/high beam switch set to HI, and auxiliary light control switch in up position. Failure to do so will cause erroneous results.
- Refer to wiring diagram for all wiring repair steps.

Step 1. Check for +24 VDC between wire 42HR (1) and ground at auxiliary headlight connector (2).

- If +24 VDC is not present, go to step 4.
- If +24 VDC is present, go to step 2.

Step 2. Remove two bolts (3), lamp guard (4), mount (5), and lamp (6).

Step 3. Check for +24 VDC between wire 42HR (1) and ground at socket (7).

- If +24 VDC is present, replace lamp.
- If +24 VDC is not present, repair wiring 42HR between socket and auxiliary headlight connector.

Step 4. Check for +24 VDC between wire 42HR (1) and ground at auxiliary light control switch (8).

- If +24 VDC is present, repair wiring 42HR between auxiliary headlight connector and auxiliary light control switch.
- If +24 VDC is not present, go to step 5.

Step 5. Check for +24 VDC between wire 41HR (9) and ground at auxiliary light control switch (8).

- If +24 VDC is present, replace auxiliary light control switch (page 4-1 46).
- If +24 VDC is not present, go to step 6.

Step 6. Disconnect connector G (10) and check for +24 VDC between wire 41HR (9) and ground.

- If +24 VDC is present, repair wiring 41HR between connector G and auxiliary light control switch.
- If +24 VDC is not present, repair wiring 41HR between fuse box 2 and connector G.

Table 3-5. Troubleshooting (Cont)

Malfunction	Test or Inspection	Corrective Action
-------------	--------------------	-------------------

ELECTRICAL SYSTEM (CONT)

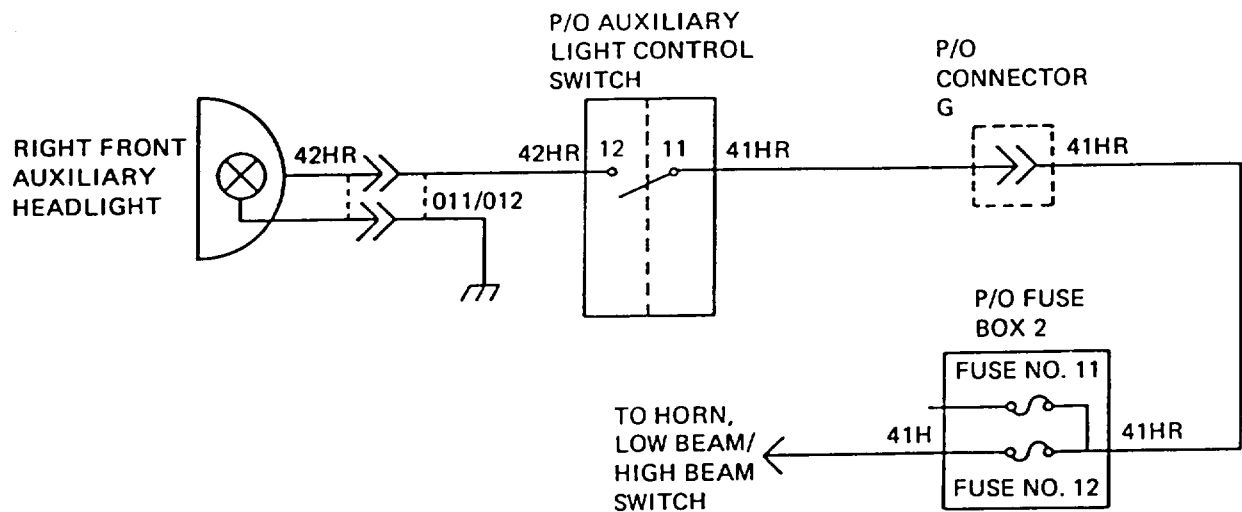
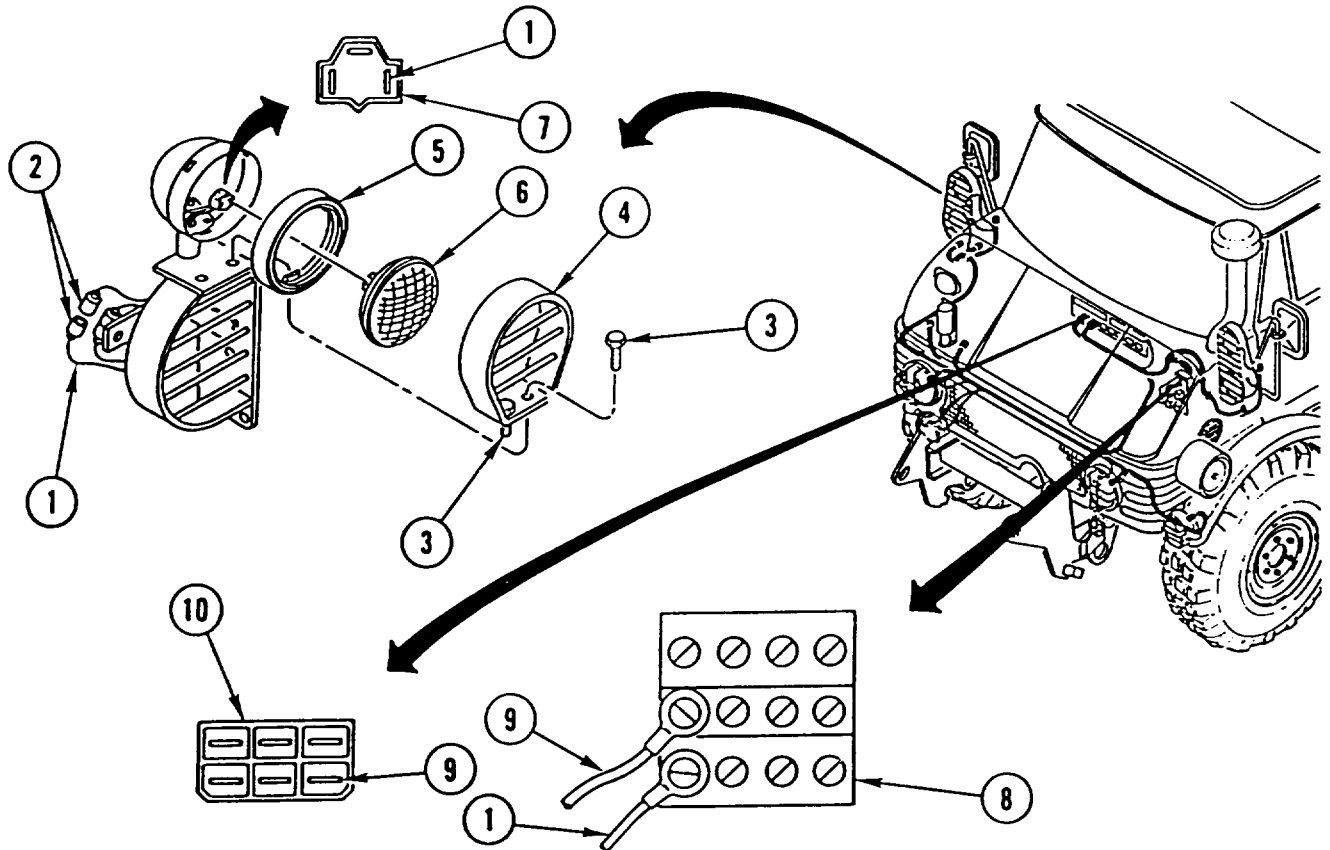

Table 3-5. Troubleshooting (Cont)

Malfunction	Test or Inspection	Corrective Action
-------------	--------------------	-------------------

ELECTRICAL SYSTEM (CONT)

20. RIGHT FRONT HEADLIGHT LOW BEAM WILL NOT LIGHT.

NOTE

Vehicle MASTER disconnect switch must be ON, master light switch set to SER DRIVE, horn, low beam/high beam switch set to LO, and auxiliary light control switch in down position. Failure to do so will cause erroneous results.

Refer to wiring diagram (page 3-98) for all wiring repair steps.

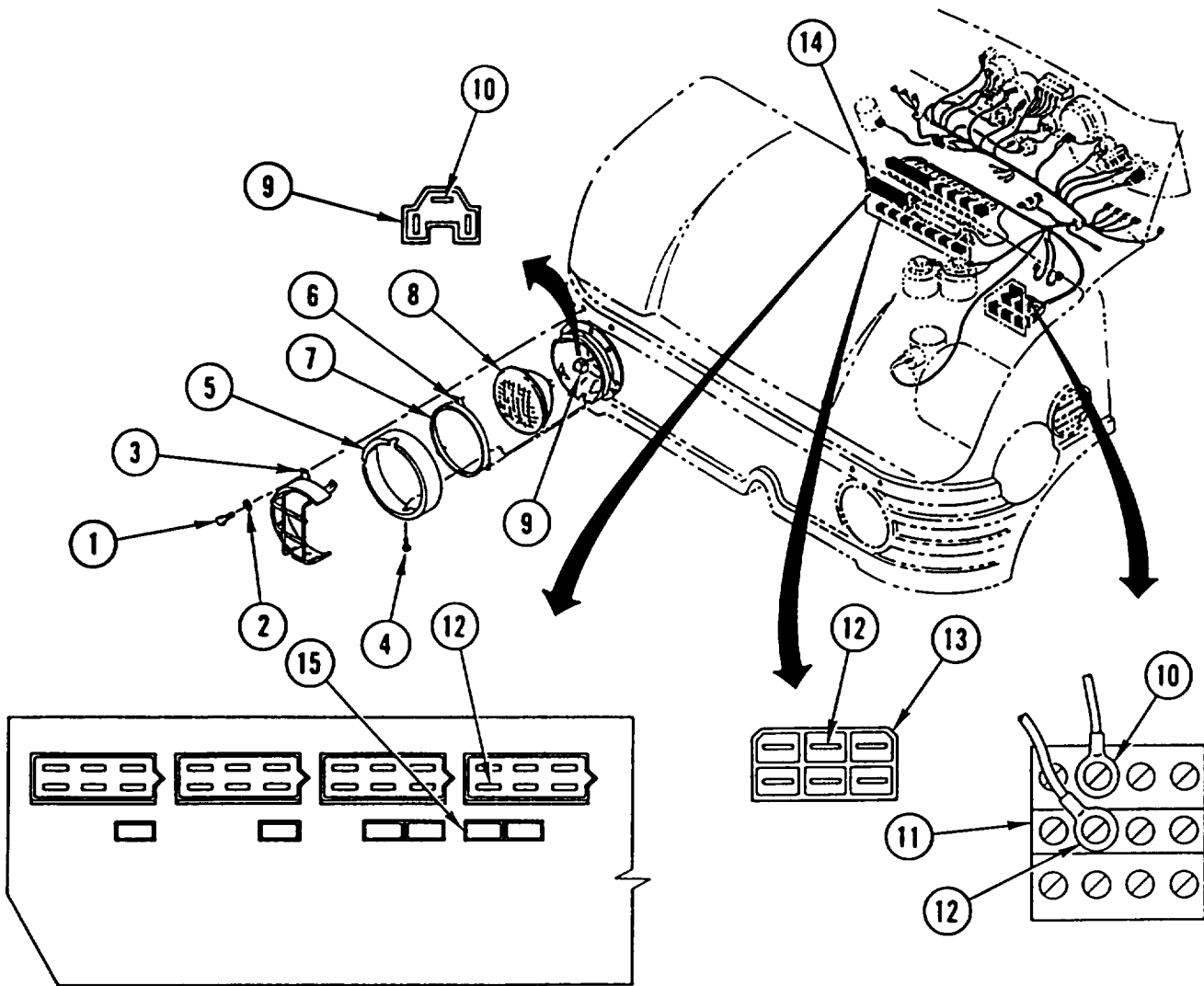

Table 3-5. Troubleshooting (Cont)

Malfunction	Test or Inspection	Corrective Action
ELECTRICAL SYSTEM (CONT)		
	Step 1. Remove three screws (1), three washers (2), and guard (3).	
	Step 2. Remove screw (4) and ring (5).	
	Step 3. Loosen three screws (6) and remove ring (7).	
	Step 4. Remove lamp (8) from socket (9).	
	Step 5. Check for +24 VDC between wire 41LR1 (10) and ground at socket (9).	<ul style="list-style-type: none"> • If +24 VDC is present, replace lamp. • If +24 VDC is not present, go to step 6.
	Step 6. Check for +24 VDC between wire 41LR1 (10) and ground at auxiliary light control switch (11).	<ul style="list-style-type: none"> • If +24 VDC is present, repair wiring 41LR1 between auxiliary light control switch and socket. • If +24 VDC is not present, go to step 7.
	Step 7. Check for +24 VDC between wire 41LR (12) and ground at auxiliary light control switch (11).	<ul style="list-style-type: none"> • If +24 VDC is present, replace auxiliary light control switch (page 4-146). • If +24 VDC is not present, go to step 8.
	Step 8. Disconnect connector G (13) and check for +24 VDC between wire 41LR (12) and ground.	<ul style="list-style-type: none"> • If +24 VDC is present, repair wiring 41LR between connector G and auxiliary light control switch. • If +24 VDC is not present, reconnect connector G and go to step 9.
	Step 9. Check for +24 VDC between wire 41LR (12) and ground at fuse box 2 (14).	<ul style="list-style-type: none"> • If +24 VDC is present, repair wiring 41LR between fuse box 2 and connector G. • If +24 VDC is not present, go to step 10.
	Step 10. Check for +24 VDC between wire 41L1 (15) and ground at fuse box 2 (14).	<ul style="list-style-type: none"> • If +24 VDC is present, replace fuse. • If +24 VDC is not present, repair wiring 41L1.

Table 3-5. Troubleshooting (Cont)

Malfunction	Test or Inspection	Corrective Action
-------------	--------------------	-------------------

ELECTRICAL SYSTEM (CONT)

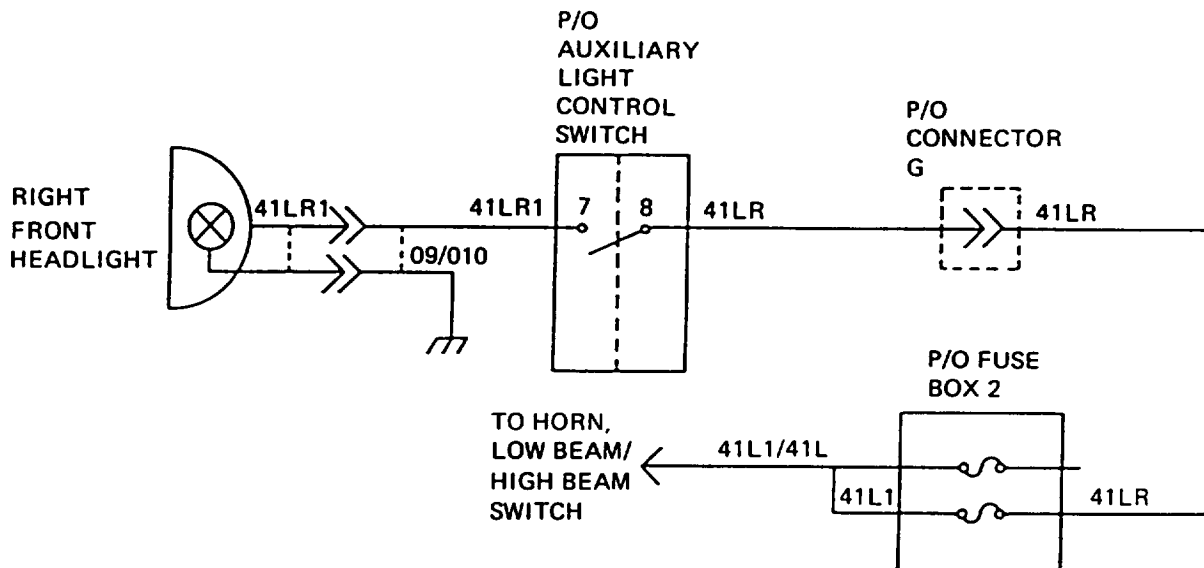

21. RIGHT FRONT HEADLIGHT HIGH BEAM WILL NOT LIGHT.

NOTE

- Vehicle MASTER disconnect switch must be ON, master light switch set to SER DRIVE, horn, low beam/high beam switch set to HI, and auxiliary light control switch in down position. Failure to do so will cause erroneous results.

- Refer to wiring diagram (page 3-100) for all wiring repair steps.

Step 1. Remove three screws (1), three washers (2), and guard (3).

Step 2. Remove screw (4) and ring (5).

Step 3. Loosen three screws (6) and remove ring (7).

Step 4. Remove lamp (8) from socket (9).

Step 5. Check for +24 VDC between wire 41HR1 (10) and ground at socket (9).

- If +24 VDC is present, replace lamp.
- If +24 VDC is not present, go to step 6.

Table 3-5. Troubleshooting (Cont)

Malfunction	Test or Inspection	Corrective Action
-------------	--------------------	-------------------

ELECTRICAL SYSTEM (CONT)

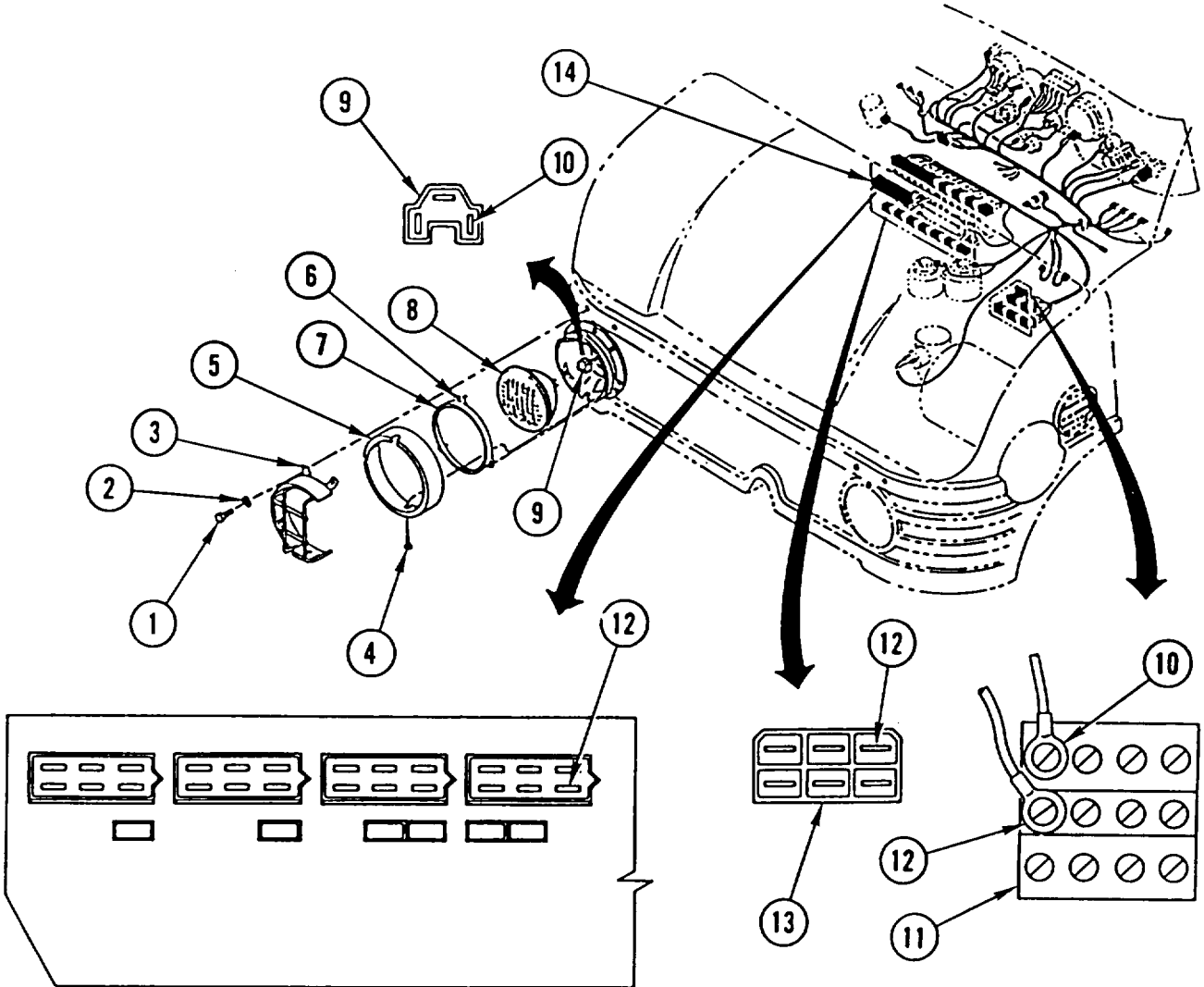

Step 6. Check for +24 VDC between wire 41HR1 (10) and ground at auxiliary light control switch (11).

- If +24 VDC is present, repair wiring 41HR1.
- If +24 VDC is not present, go to step 7.

Step 7. Check for +24 VDC between wire 41HR (12) and ground at auxiliary light control switch (11).

- If +24 VDC is present, replace auxiliary light control switch (page 4-146).
- If +24 VDC is not present, go to step 8.

Table 3-5. Troubleshooting (Cont)

Malfunction	Test or Inspection	Corrective Action
-------------	--------------------	-------------------

ELECTRICAL SYSTEM (CONT)

Step 8. Disconnect connector G (13) and check for +24 VDC between wire 41HR (12) and ground.

- If +24 VDC is present, repair wiring 41HR between connector G and auxiliary light control switch.
- If +24 VDC is not present, reconnect connector G and go to step 9.

Step 9. Check for +24 VDC between wire 41HR (12) and ground at fuse box 2 (14).

- If +24 VDC is not present, replace fuse.
- If +24 VDC is present, repair wiring 41HR between fuse box 2 and connector G.

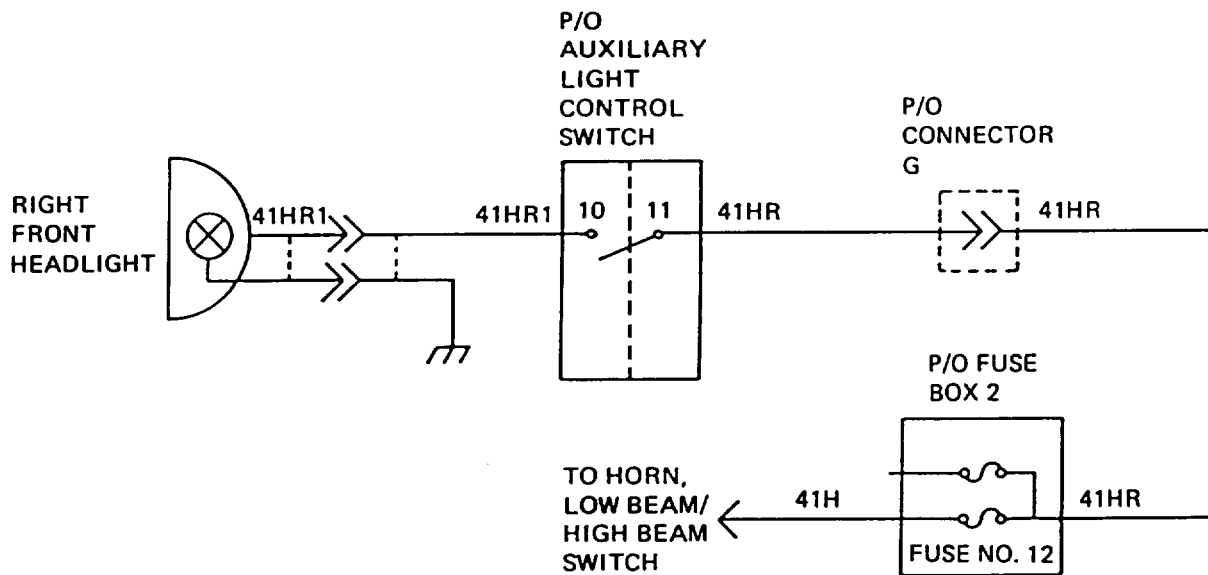

Table 3-5. Troubleshooting (Cont)

Malfunction	Test or Inspection	Corrective Action
-------------	--------------------	-------------------

ELECTRICAL SYSTEM (CONT)

22. LEFT FRONT AUXILIARY HEADLIGHT LOW BEAM WILL NOT LIGHT.

NOTE

- Vehicle MASTER disconnect switch must be ON, master light switch set to SER DRIVE, horn, low beam/high beam switch set to LO, and auxiliary light control switch in up position. Failure to do so will cause erroneous results.
- Refer to wiring diagram (page 3-103) for all wiring repair steps.

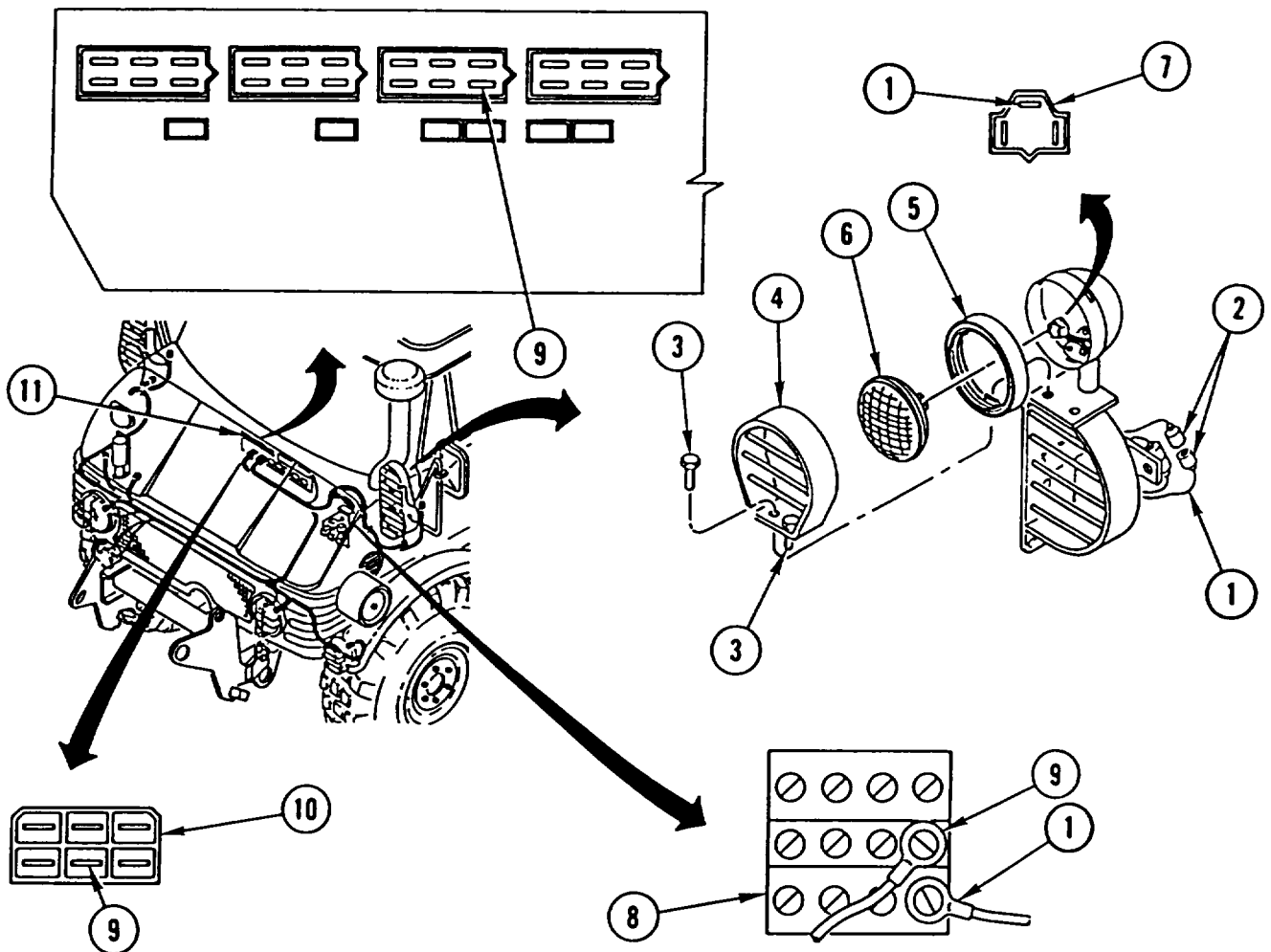

Table 3-5. Troubleshooting (Cont)

Malfunction	Test or Inspection	Corrective Action
ELECTRICAL SYSTEM (CONT)		
	Step 1. Check for +24 VDC between wire 42LL (1) and ground at auxiliary headlight connector (2).	<ul style="list-style-type: none"> • If +24 VDC is not present, go to step 4. • If +24 VDC is present, go to step 2.
	Step 2. Remove two bolts (3), lamp guard (4), mount (5), and lamp (6).	
	Step 3. Check for +24 VDC between wire 42LL (1) and ground at socket (7).	<ul style="list-style-type: none"> • If +24 VDC is present, replace lamp. • If +24 VDC is not present, repair wiring 42LL between socket and auxiliary headlight connector.
	Step 4. Check for +24 VDC between wire 42LL (1) and ground at auxiliary light control switch (8).	<p>If +24 VDC is present, repair wiring 42LL between auxiliary light control switch and auxiliary headlight connector.</p> <p>If +24 VDC is not present, go to step 5.</p>
	Step 5. Check for +24 VDC between wire 41LL (9) and ground at auxiliary light control switch (8).	<ul style="list-style-type: none"> • If +24 VDC is present, replace auxiliary light control switch (page 4-146). • If +24 VDC is not present, go to step 6.
	Step 6. Disconnect connector G (10) and check for +24 VDC between wire 41LL (9) and ground.	<ul style="list-style-type: none"> • If +24 VDC is present, repair wiring 41LL between connector G and auxiliary light control switch. • If +24 VDC is not present, reconnect connector G and go to step 7.
	Step 7. Check for +24 VDC between wire 41LL (9) and ground at fuse box 2 (11).	<ul style="list-style-type: none"> • If +24 VDC is not present, replace fuse. • If +24 VDC is present, repair wiring 41LL between fuse box 2 and connector G.

Table 3-5. Troubleshooting (Cont)

Malfunction	Test or Inspection	Corrective Action
-------------	--------------------	-------------------

ELECTRICAL SYSTEM (CONT)

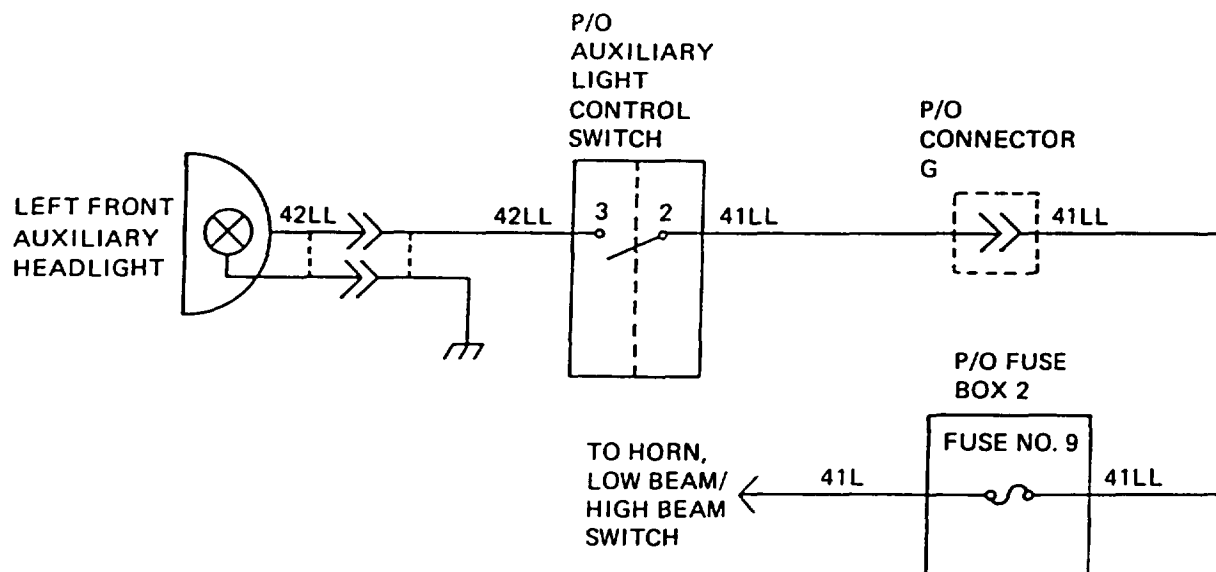

23. LEFT FRONT AUXILIARY HEADLIGHT HIGH BEAM WILL NOT LIGHT.

NOTE

- Vehicle MASTER disconnect switch must be ON, master light switch set to SER DRIVE, horn, low beam/high beam switch set to HI, and auxiliary light control switch in up position. Failure to do so will cause erroneous results.
- Refer to wiring diagram (page 3-105) for all wiring repair steps.

Step 1. Check for +24 VDC between wire 42HL (1) and ground at auxiliary headlight connector (2).

- If +24 VDC is not present, go to step 4.
- If +24 VDC is present, go to step 2.

Step 2. Remove two bolts (3), lamp guard (4), mount (5), and lamp (6).

Step 3. Check for +24 VDC between wire 42HL (1) and ground at socket (7).

- If +24 VDC is present, replace lamp.
- If +24 VDC is not present, repair wiring 42HL between socket and auxiliary headlight connector.

Table 3-5. Troubleshooting (Cont)

Malfunction	Test or Inspection	Corrective Action
-------------	--------------------	-------------------

ELECTRICAL SYSTEM (CONT)

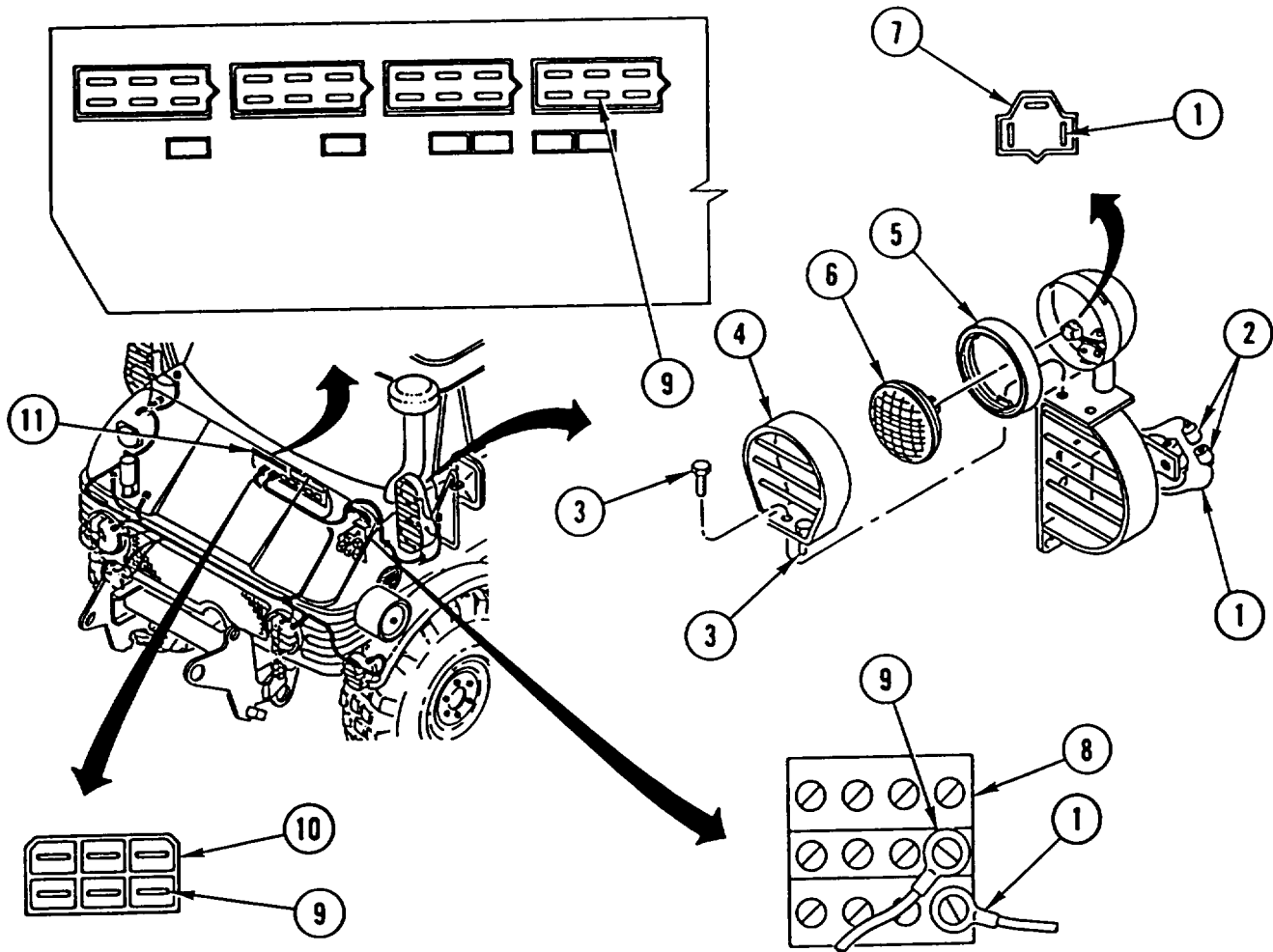

Step 4. Check for +24 VDC between wire 42HL (1) and ground at auxiliary light control switch (8).

- If +24 VDC is present, repair wiring 42HL between auxiliary headlight connector and auxiliary light control switch.
- If +24 VDC is not present, go to step 5.

Table 3-5. Troubleshooting (Cont)

Malfunction	Test or Inspection	Corrective Action
-------------	--------------------	-------------------

ELECTRICAL SYSTEM (CONT)

Step 5. Check for +24 VDC between wire 41HL (9) and ground at auxiliary light control switch (8).

- If +24 VDC is present, replace auxiliary light control switch (page 4-146).
- If +24 VDC is not present, go to step 6.

Step 6. Disconnect connector G (10) and check for +24 VDC between wire 41HL (9) and ground.

- If +24 VDC is present, repair wiring 41HL between connector G and auxiliary light control switch.
- If +24 VDC is not present, reconnect connector G and go to step 7.

Step 7. Check for +24 VDC between wire 41HL (9) and ground at fuse box 2 (11).

- If +24 VDC is not present, replace fuse.
- If +24 VDC is present, repair wiring 41HL between fuse box 2 and connector G.

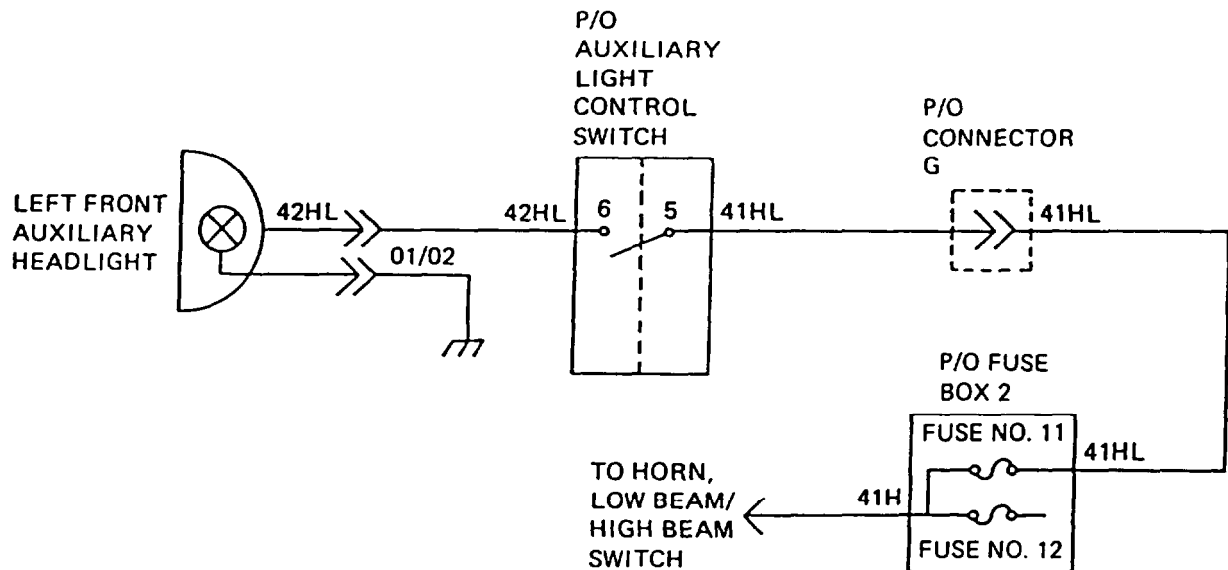

Table 3-5. Troubleshooting (Cont)

Malfunction

Test or Inspection

Corrective Action

ELECTRICAL SYSTEM (CONT)

24. LEFT FRONT HEADLIGHT LOW BEAM WILL NOT LIGHT.

NOTE

- Vehicle MASTER disconnect switch must be ON, master light switch set to SER DRIVE, horn, low beam/high beam switch set to LO, and auxiliary light control switch in down position. Failure to do so will cause erroneous results.
- Refer to wiring diagram for all wiring repair steps.

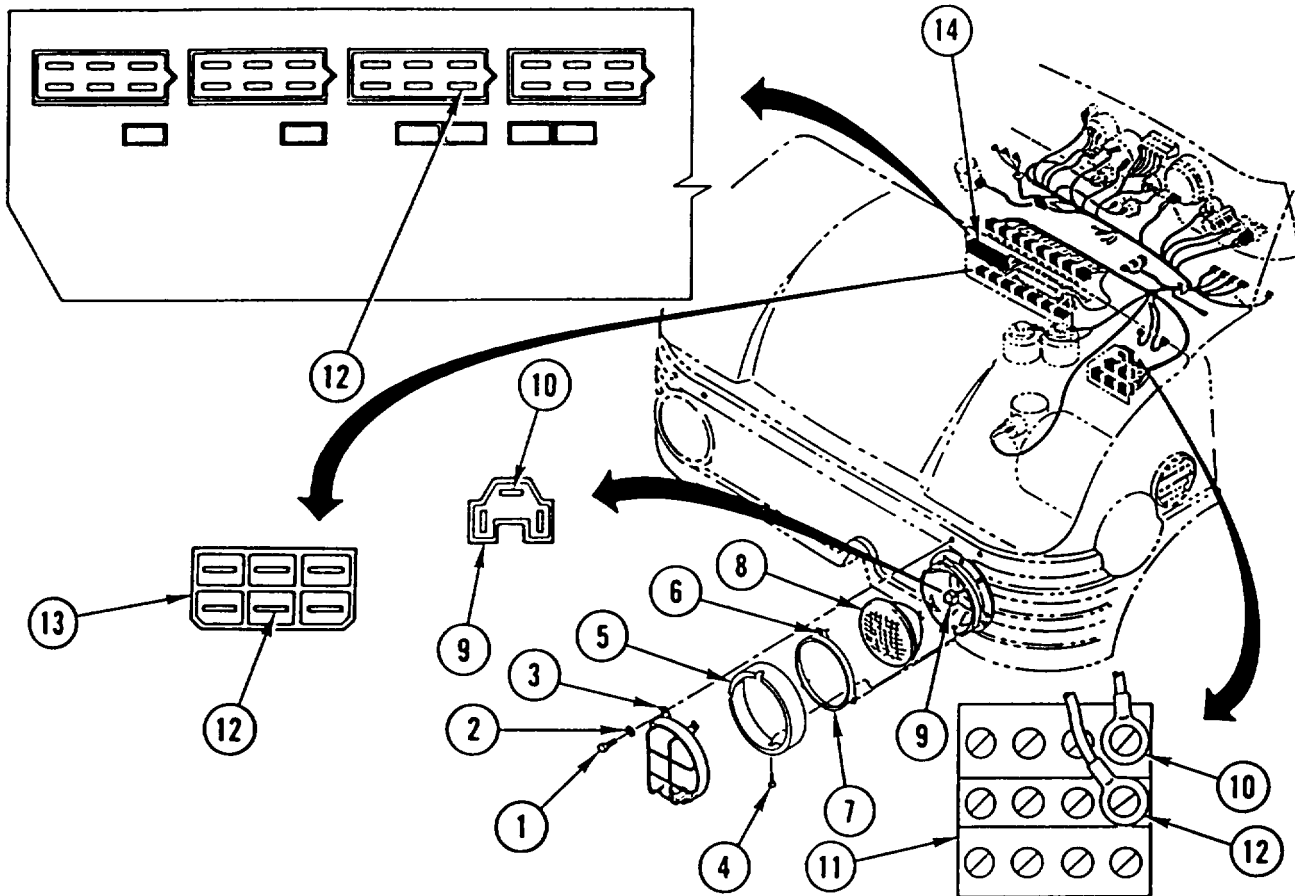

Step 1. Remove three screws (1), three washers (2), and guard (3).

Step 2. Remove screw (4) and ring (5).

Step 3. Loosen three screws (6) and remove ring (7).

Step 4. Remove lamp (8) from socket (9).

Table 3-5. Troubleshooting (Cont)

Malfunction	Test or Inspection	Corrective Action
-------------	--------------------	-------------------

ELECTRICAL SYSTEM (CONT)

- Step 5. Check for +24 VDC between wire 41LL1 (10) and ground at socket (9).
- If +24 VDC is present, replace lamp.
 - If +24 VDC is not present, go to step 6.
- Step 6. Check for +24 VDC between wire 41LL1 (10) and ground at auxiliary light control switch (11).
- If +24 VDC is present, repair wiring 41LL1.
 - If +24 VDC is not present, go to step 7.
- Step 7. Check for +24 VDC between wire 41LL (12) and ground at auxiliary light control switch (11).
- If +24 VDC is present, replace auxiliary light control switch (page 4-146).
 - If +24 VDC is not present, go to step 8.
- Step 8. Disconnect connector G (13) and check for +24 VDC between wire 41LL (12) and ground.
- If +24 VDC is present, repair wiring 41LL between connector G and auxiliary light control switch.
 - If +24 VDC is not present, reconnect connector G and go to step 9.
- Step 9. Check for +24 VDC between wire 41LL (12) and ground at fuse box 2 (14).
- If +24 VDC is not present, replace fuse.
 - If +24 VDC is present, repair wiring 41LL between fuse box 2 and connector G.

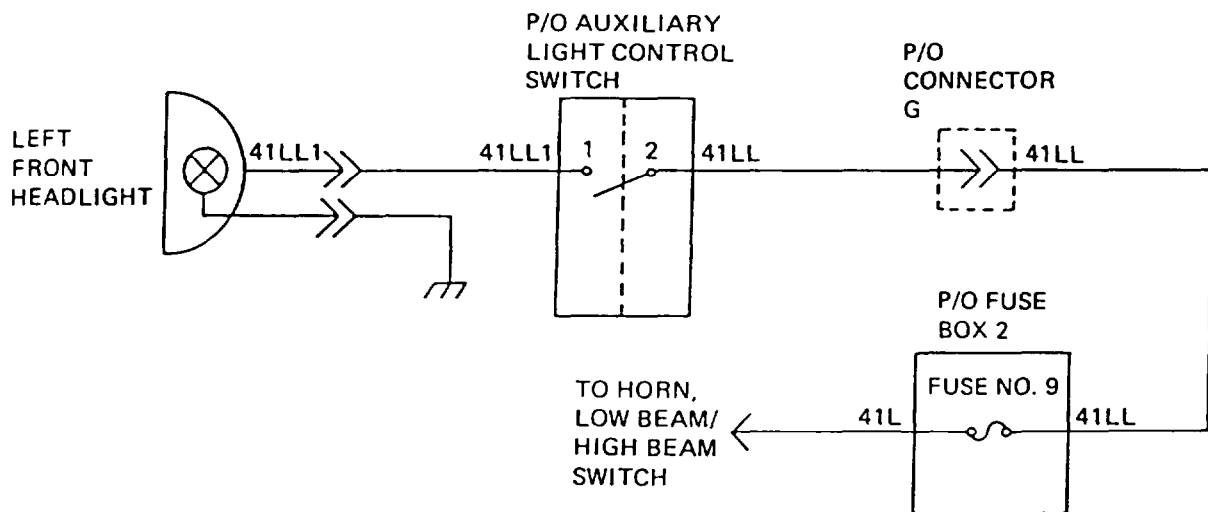

Table 3-5. Troubleshooting (Cont)

Malfunction	Test or Inspection	Corrective Action
-------------	--------------------	-------------------

ELECTRICAL SYSTEM (CONT)

25. LEFT FRONT HEADLIGHT HIGH BEAM WILL NOT LIGHT.

NOTE

- Vehicle MASTER disconnect switch must be ON. master light switch set to SER DRIVE, horn, low beam/high beam switch set to HI, and auxiliary light control switch in down position. Failure to do so will cause erroneous results.
- Refer to wiring diagram for all wiring repair steps.

Step 1. Remove three screws (1), three washers (2), and guard (3).

Step 2. Remove screw (4) and ring (5).

Step 3. Loosen three screws (6) and remove ring (7).

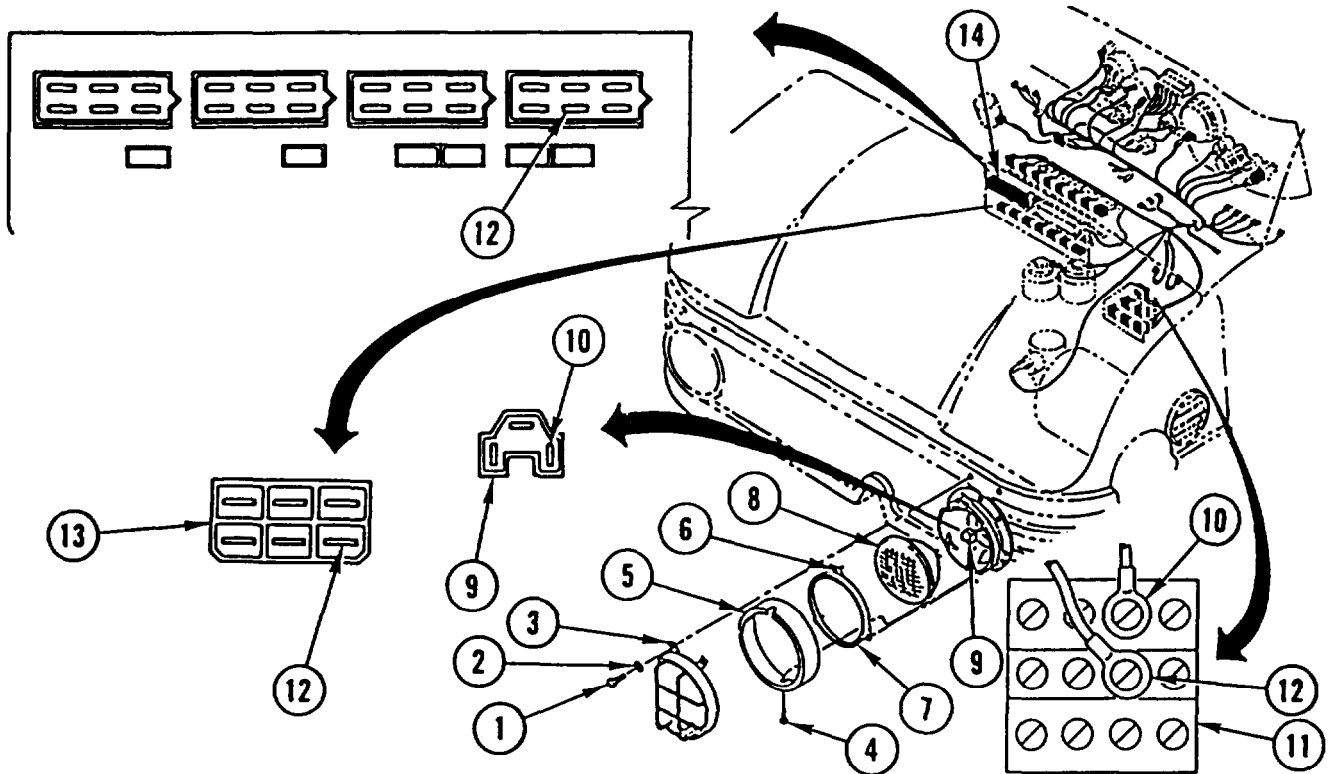

Step 4. Remove lamp (8) from socket (9).

Step 5. Check for +24 VDC between wire 41HL1 (10) and ground at socket (9).

- If +24 VDC is present, replace lamp.
- If +24 VDC is not present, go to step 6.

Table 3-5. Troubleshooting (Cont)

Malfunction	Test or Inspection	Corrective Action
-------------	--------------------	-------------------

ELECTRICAL SYSTEM (CONT)

Step 6. Check for +24 VDC between wire 41HL1 (10) and ground at auxiliary light control switch (11).

- If +24 VDC is present, repair wiring 41HL1.
- If +24 VDC is not present, go to step 7.

Step 7. Check for +24 VDC between wire 41HL (12) and ground at auxiliary light control switch (11).

- If +24 VDC is present, replace auxiliary light control switch (page 4-146).
- If +24 VDC is not present, go to step 8.

Step 8. Disconnect connector G (13) and check for +24 VDC between wire 41HL (12) and ground.

- If +24 VDC is present, repair wiring 41HL between connector G and auxiliary light control switch.
- If +24 VDC is not present, reconnect connector G and go to step 9.

Step 9. Check for +24 VDC between wire 41HL (12) and ground at fuse box 2 (14).

- If +24 VDC is not present, replace fuse.
- If +24 VDC is present, repair wiring 41HL between fuse box 2 and connector G.

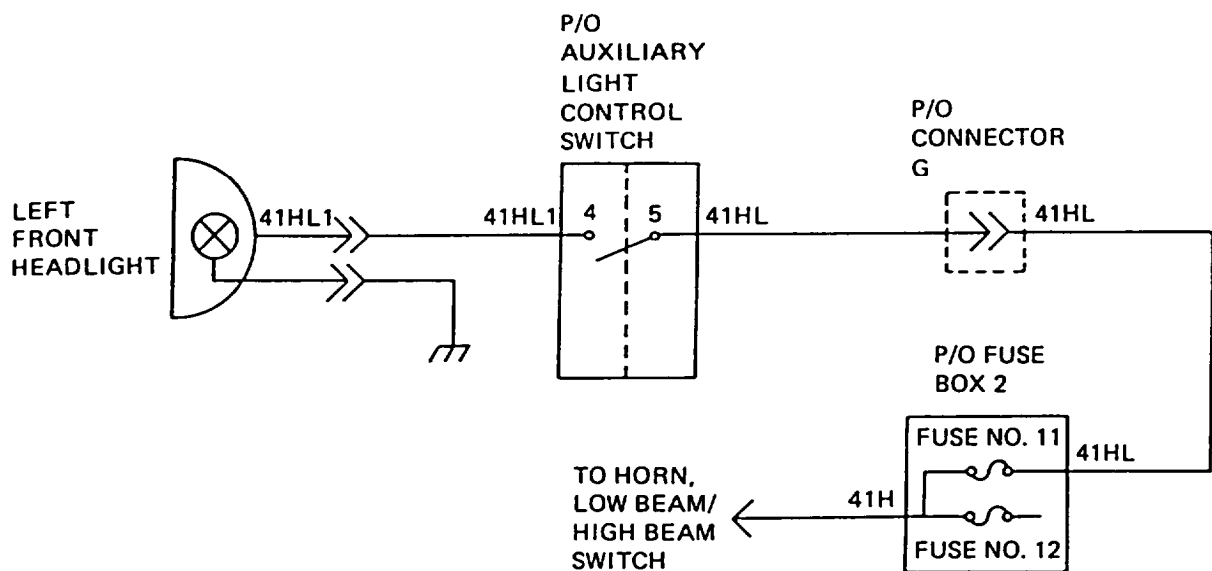

Table 3-5. Troubleshooting (Cont)

Malfunction	Test or Inspection	Corrective Action
-------------	--------------------	-------------------

ELECTRIAL SYSTEM (CONT)

26. RIGHT FRONT TURN SIGNAL WILL NOT LIGHT.

NOTE

- Vehicle MASTER disconnect switch must be ON, master light switch set to SER DRIVE, and turn signal lever switched to R position. Failure to do so will cause erroneous results.
- Refer to wiring diagram for all wiring repair steps.

Step 1. Check for +24 VDC between wire 45FR (1) and ground at quick disconnect (2).

- If +24 VDC is present, replace lamp (3) (page 4-183).
- If +24 VDC is not present, go to step 2.

Step 2. Disconnect connector G (4) and check for +24 VDC between wire 45FR (1) and ground.

- If +24 VDC is present, repair wiring 45FR between connector G and lamp.
- If +24 VDC is not present, reconnect connector G and go to step 3.

Step 3. Check for +24 VDC between wire 45FR (1) and ground at turn signal lever (5).

- If +24 VDC is not present, replace turn signal lever (page 4-1 22).
- If +24 VDC is present, repair wiring 45FR between turn signal lever and connector G.

Table 3-5. Troubleshooting (Cont)

Malfunction	Test or Inspection	Corrective Action
-------------	--------------------	-------------------

ELECTRICAL SYSTEM (CONT)

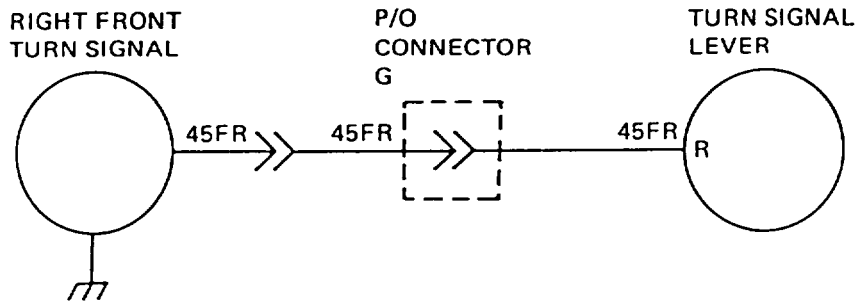
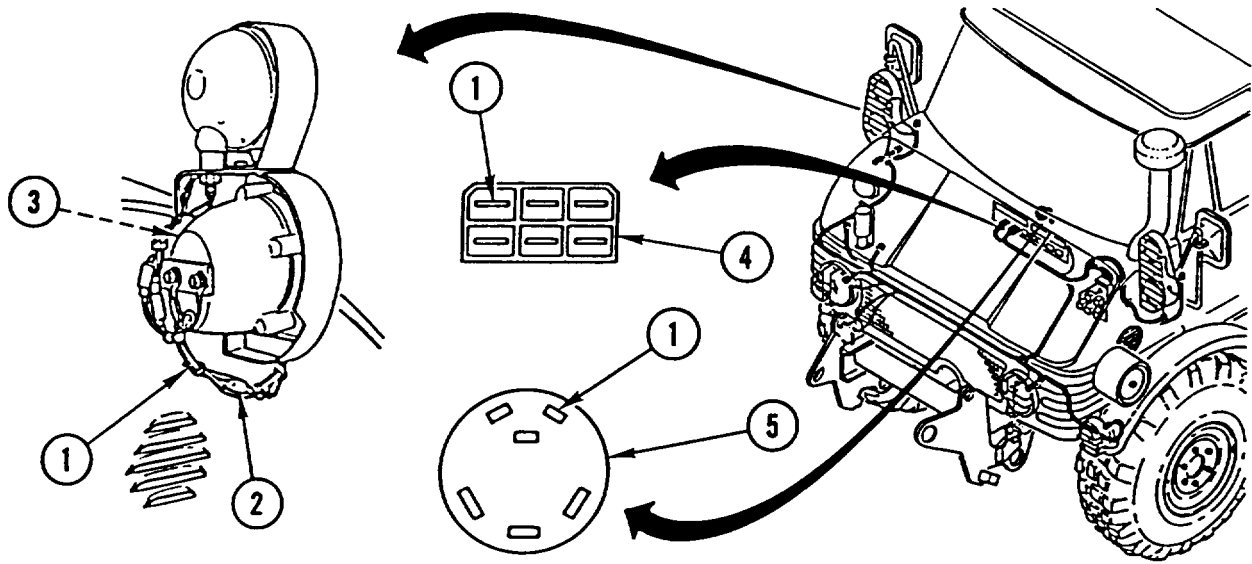

Table 3-5. Troubleshooting (Cont)

Malfunction
Test or Inspection**Corrective Action**

ELECTRICAL SYSTEM (CONT)

27. RIGHT FRONT MARKER LIGHT WILL NOT LIGHT.

NOTE

- Vehicle MASTER disconnect switch must be ON and master light switch set to SER DRIVE. Failure to do so will cause erroneous results.
- Refer to wiring diagram for all wiring repair steps.

Step 1. Check for +24 VDC between wire 41 CI (1) and ground at quick disconnect (2).

- If +24 VDC is present, replace lamp (3) (page 4-183).
- If +24 VDC is not present, go to step 2.

Step 2. Disconnect connector F (4) and check for +24 VDC between wire 41C1 (1) and ground.

- If +24 VDC is present, repair wiring 41C1 between connector F and lamp.
- If +24 VDC is not present, reconnect connector F and go to step 3.

Step 3. Check for +24 VDC between wire 41C1 (1) and ground at fuse box 2 (5).

- If +24 VDC is not present, replace fuse.
- If +24 VDC is present, repair wiring 41C1 between fuse box 2 and connector F.

Table 3-5. Troubleshooting (Cont)

Malfunction
 Test or Inspection
 Corrective Action

ELECTRICAL SYSTEM (CONT)

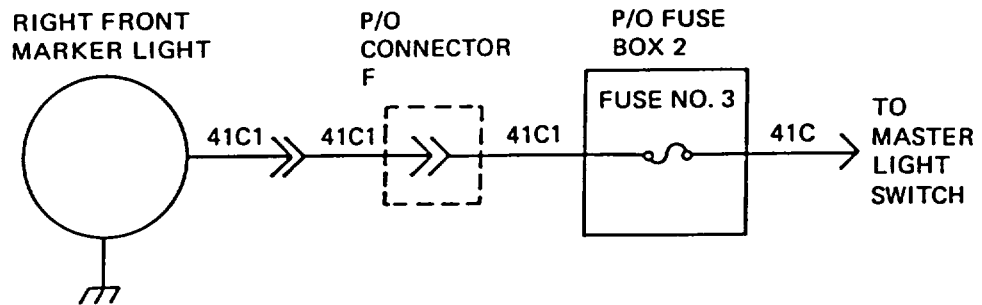
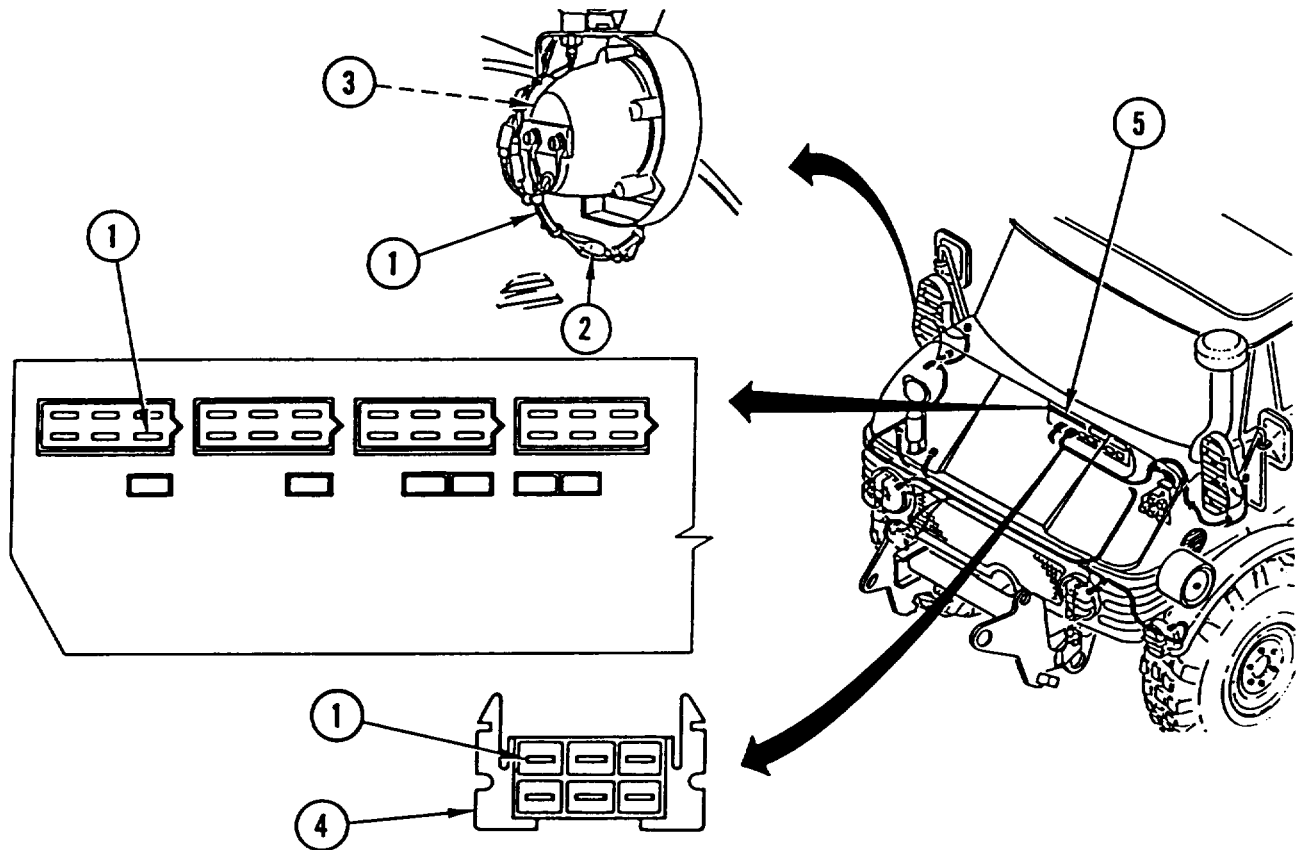

Table 3-5. Troubleshooting (Cont)

Malfunction	Test or Inspection	Corrective Action
-------------	--------------------	-------------------

ELECTRICAL SYSTEM (CONT)

28. RIGHT FRONT BLACKOUT MARKER LIGHT WILL NOT LIGHT.

NOTE

- Vehicle MASTER disconnect switch must be ON and master light switch set to BO MARKER. Failure to do so will cause erroneous results.
- Refer to wiring diagram for all wiring repair steps.

Step 1. Check for +24 VDC between wire 484 (1) and ground at quick disconnect (2).

- If +24 VDC is present, replace lamp (3) (page 4-181).
- If +24 VDC is not present, go to step 2.

Step 2. Disconnect connector F (4) and check for +24 VDC between wire 484 (1) and ground.

- If +24 VDC is present, repair wiring 484 between connector F and lamp.
- If +24 VDC is not present, reconnect connector F and go to step 3.

Step 3. Check for +24 VDC between wire 484 (1) and ground at fuse box 1 (5).

- If +24 VDC is not present, replace fuse.
- If +24 VDC is present, repair wiring 484 between fuse box 1 and connector F.

Table 3-5. Troubleshooting (Cont)

Malfunction	Test or Inspection	Corrective Action
-------------	--------------------	-------------------

ELECTRICAL SYSTEM (CONT)

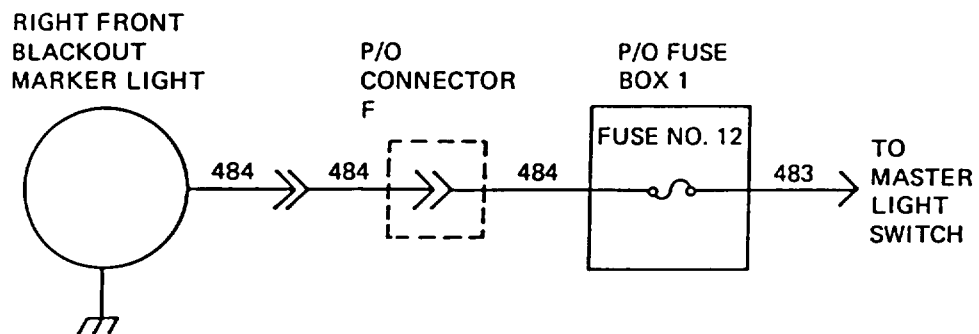
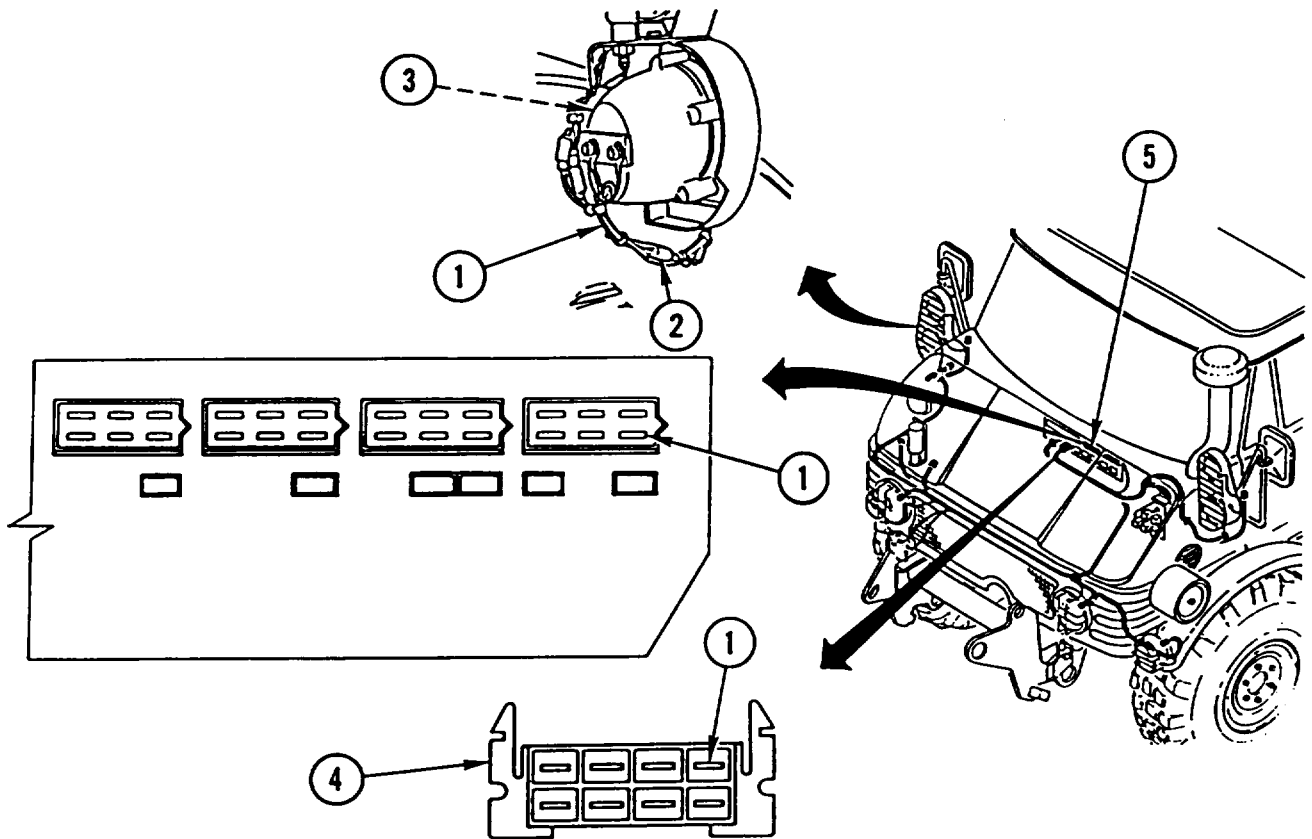

Table 3-5. Troubleshooting (Cont)

Malfunction	Test or Inspection	Corrective Action
ELECTRICAL SYSTEM (CONT)		
29. LEFT FRONT TURN SIGNAL WILL NOT LIGHT.		
NOTE		
<ul style="list-style-type: none"> • Vehicle MASTER disconnect switch must be ON, master light switch set to SER DRIVE, and turn signal lever switched to L. Failure to do so will cause erroneous results. • Refer to wiring diagram for all wiring repair steps. 		
<p>Step 1. Check for +24 VDC between wire 45FL (1) and ground at quick disconnect (2).</p> <ul style="list-style-type: none"> • If +24 VDC is present, replace lamp (3) (page 4-183). • If +24 VDC is not present, go to step 2. 		
<p>Step 2. Disconnect connector G (4) and check for +24 VDC between wire 45FL (1) and ground.</p> <ul style="list-style-type: none"> • If +24 VDC is present, repair wiring 45FL between connector G and lamp. • If +24 VDC is not present, reconnect connector G and go to step 3. 		
<p>Step 3. Check for +24 VDC between wire 45FL (1) and ground at turn signal lever (5).</p> <ul style="list-style-type: none"> • If +24 VDC is not present, replace turn signal lever (page 4-1 22). • If +24 VDC is present, repair wiring 45FL between turn signal lever and connector G. 		

Table 3-5. Troubleshooting (Cont)

Malfunction	Test or Inspection	Corrective Action
-------------	--------------------	-------------------

ELECTRICAL SYSTEM (CONT)

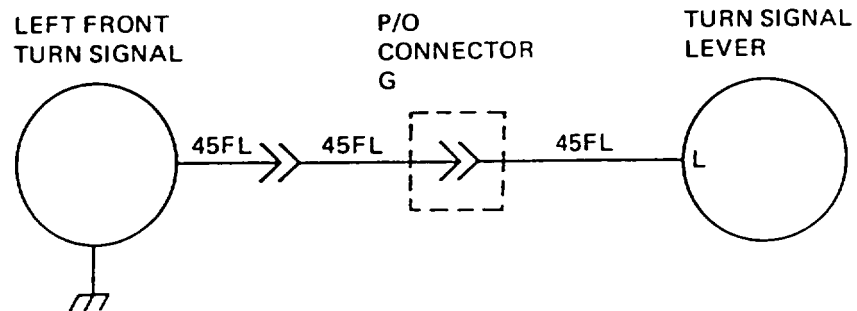
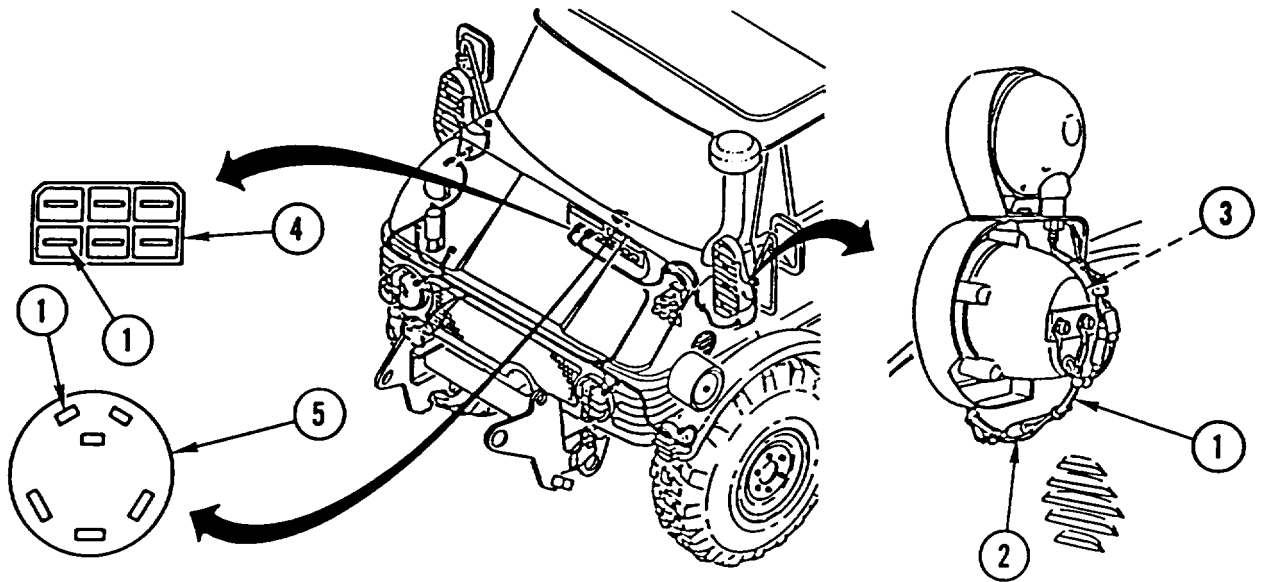

Table 3-5. Troubleshooting (Cont)

Malfunction	Test or Inspection	Corrective Action
-------------	--------------------	-------------------

ELECTRICAL SYSTEM (CONT)

30. LEFT FRONT MARKER LIGHT WILL NOT LIGHT.

NOTE

- Vehicle MASTER disconnect switch must be ON and master light switch set to SER DRIVE. Failure to do so will cause erroneous results.
- Refer to wiring diagram for all wiring repair steps.

Step 1. Check for +24 VDC between wire 41C2 (1) and ground at quick disconnect (2).

- If +24 VDC is present, replace lamp (3) (page 4-183).
- If +24 VDC is not present, go to step 2.

Step 2. Disconnect connector F (4) and check for +24 VDC between wire 41C2 (1) and ground.

- If +24 VDC is present, repair wiring 41C2 between connector F and lamp.
- If +24 VDC is not present, reconnect connector F and go to step 3.

Step 3. Check for +24 VDC between wire 41C2 (1) and ground at fuse box 2 (5).

- If +24 VDC is not present, replace fuse.
- If +24 VDC is present, repair wiring 41C2 between fuse box 2 and connector F.

Table 3-5. Troubleshooting (Cont)

Malfunction	Test or Inspection	Corrective Action
-------------	--------------------	-------------------

ELECTRICAL SYSTEM (CONT)

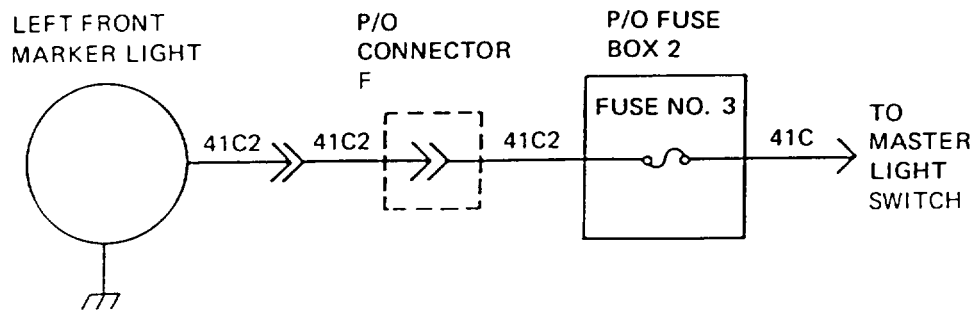
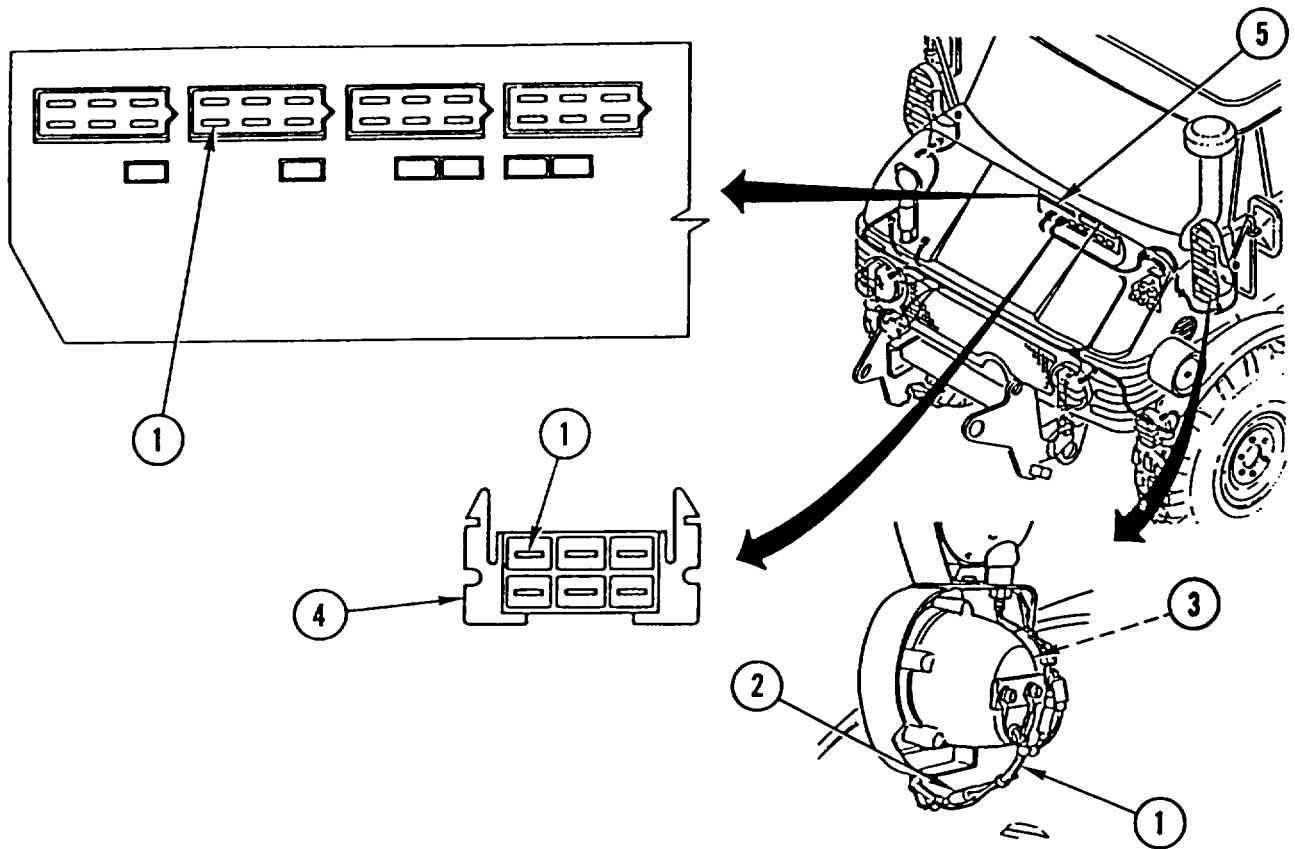

Table 3-5. Troubleshooting (Cont)

Malfunction	Test or Inspection	Corrective Action
-------------	--------------------	-------------------

ELECTRICAL SYSTEM (CONT)

31. LEFT FRONT BLACKOUT MARKER LIGHT WILL NOT LIGHT.

NOTE

- Vehicle MASTER disconnect switch must be ON and master light switch set to 60 MARKER. Failure to do so will cause erroneous results.
- Refer to wiring diagram for all wiring repair steps.

Check for +24 VDC between wire 485 (1) and ground at quick disconnect (2).

- If +24 VDC is present, replace lamp (3) (page 4-181).
- If +24 VDC is not present, repair wiring 485 between connector F and lamp.

Table 3-5. Troubleshooting (Cont)

Malfunction	Test or Inspection	Corrective Action
-------------	--------------------	-------------------

ELECTRICAL SYSTEM (CONT)

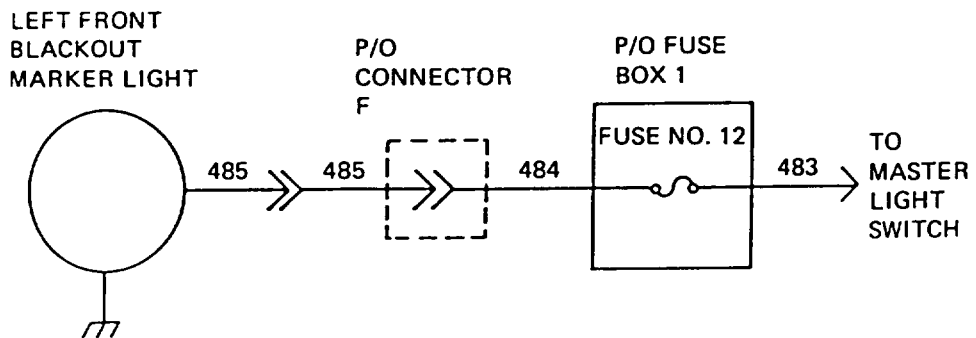
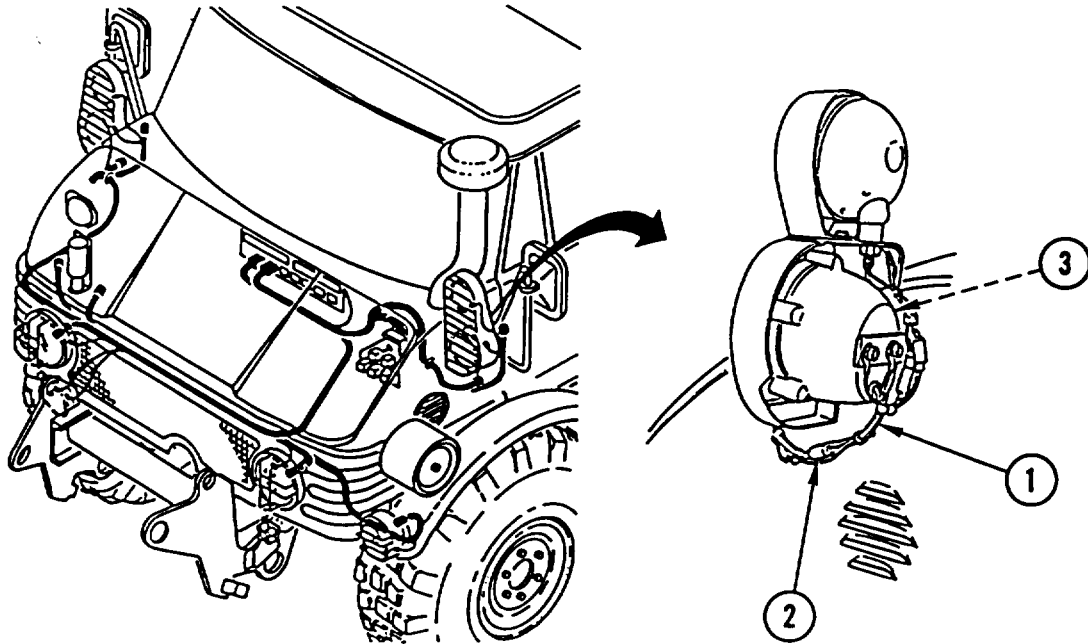

Table 3-5. Troubleshooting (Cont)

Malfunction	Test or Inspection	Corrective Action
-------------	--------------------	-------------------

ELECTRICAL SYSTEM (CONT)

32. FRONT BLACKOUT LIGHT WILL NOT LIGHT.

NOTE

- Vehicle MASTER disconnect switch must be ON and master light" switch set to BO DRIVE. Failure to do so will cause erroneous results.
- Refer to wiring diagram for all wiring repair steps.

Step 1. Check for +24 VDC between wire 401 (1) and ground at quick disconnect (2).

- If +24 VDC is present, replace lamp (3) (page 4-181).
- If +24 VDC is not present, go to step 2.

Step 2. Disconnect connector F (4) and check for +24 VDC between wire 401 (1) and ground.

- If +24 VDC is present, repair wiring 401 between connector F and lamp.
- If +24 VDC is not present, reconnect connector F and go to step 3.

Step 3. Check for +24 VDC between wire 401 (1) and ground at fuse box 2 (5).

- If +24 VDC is present, repair wiring 401 between fuse box 2 and connector F.
- If +24 VDC is not present, go to step 4.

Step 4. Disconnect connector K (6) and check for +24 VDC between wire 40 (7) and ground.

- If +24 VDC is present, repair wiring 40 between connector K and fuse box 2.
- If +24 VDC is not present, reconnect connector K and go to step 5.

Step 5. Check for +24 VDC between wire 40 (7) and ground at master light switch (8).

- If +24 VDC is not present, replace master light switch (page 4-137j).
- If +24 VDC is present, repair wiring 40 between master light switch and connector K.

Table 3-5. Troubleshooting (Cont)

Malfunction	Test or Inspection	Corrective Action
-------------	--------------------	-------------------

ELECTRICAL SYSTEM (CONT)

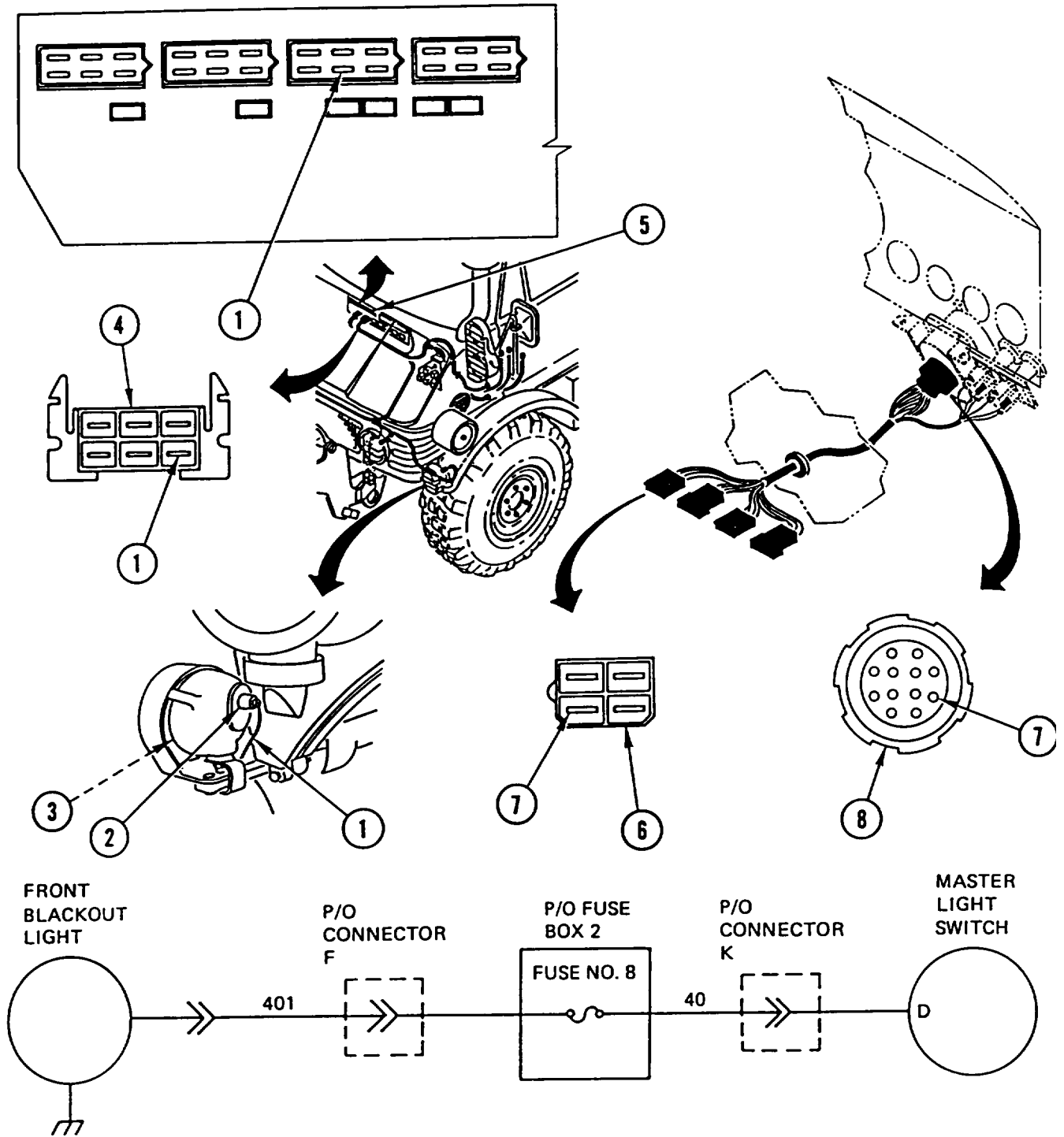

Table 3-5. Troubleshooting (Cont)

Malfunction	Test or Inspection	Corrective Action
-------------	--------------------	-------------------

ELECTRICAL SYSTEM (CONT)

33. HORN WILL NOT SOUND.

NOTE

- Vehicle MASTER disconnect switch must be ON, master light switch set to SER DRIVE, and horn button depressed. Failure to do so will cause erroneous results.
- Refer to wiring diagram for ail wiring repair steps.

- Step 1. Check for +24 VDC between wire 641 (1) and ground at horn (2).
- If +24 VDC is present, replace horn (page 4-218).
 - If +24 VDC is not present, go to step 2.
- Step 2. Disconnect connector F (3) and check for +24 VDC between wire 641 (1) and ground.
- If +24 VDC is present, repair wiring 641 between connector F and horn.
 - If +24 VDC is not present, reconnect connector F and go to step 3.
- Step 3. Remove two clamps (4) and intake pipe (5).
- Step 4. Loosen two captive screws (6) and pull bracket (7) out enough to gain access to area behind bracket.
- Step 5. Disconnect connector AD (8) and check for +24 VDC between wire 641 (1) and ground.
- If +24 VDC is present, repair wiring 641 between connector AD and connector F.
 - If +24 VDC is not present, go to step 6.
- Step 6. With connector AD (8) disconnected, check for +24 VDC between wire 64 (9) and ground at connector AD.
- If +24 VDC is present, replace horn, low beam/high beam switch (page 4-215).
 - If +24 VDC is not present, reconnect connector AD and go to step 7.
- Step 7. Check for +24 VDC between wire 64 (9) and ground at fuse box 1 (10).
- If +24 VDC is not present, replace fuse.
 - If +24 VDC is present, repair wiring 64 between fuse box 1 and horn, low beam/high beam switch.

Table 3-5. Troubleshooting (Cont)

Malfunction	Test or Inspection	Corrective Action
-------------	--------------------	-------------------

ELECTRICAL SYSTEM (CONT)

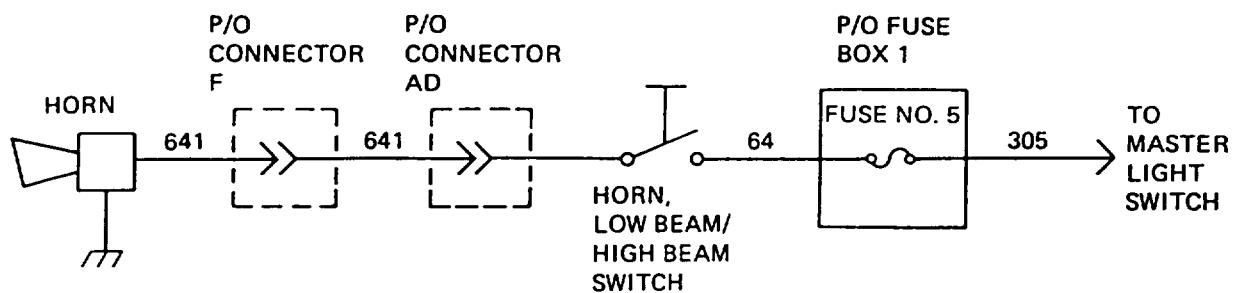
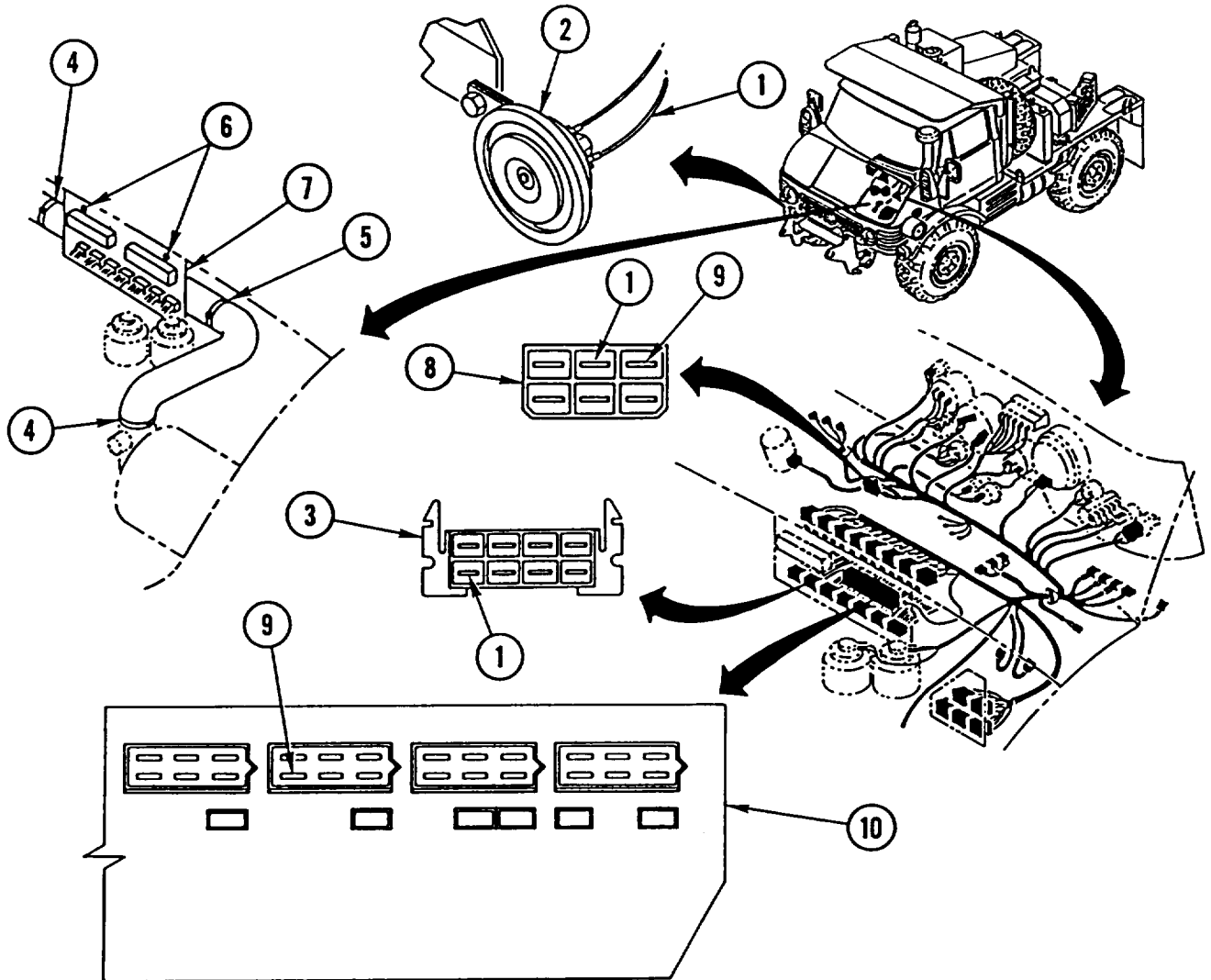

Table 3-5. Troubleshooting (Cont)

Malfunction	Test or Inspection	Corrective Action
-------------	--------------------	-------------------

ELECTRICAL SYSTEM (CONT)

34. WINDSHIELD WASHER PUMP WILL NOT OPERATE.

NOTE

- Vehicle MASTER disconnect switch must be ON, ignition switch set to ON, and windshield wiper/washer switch engaged. Failure to do so will cause erroneous results.
- Refer to wiring diagram for all wiring repair steps.

Step 1. Check for +24 VDC between wire 638 (1) and ground at windshield washer pump connector (2).

- If +24 VDC is present, replace windshield washer pump (page 4-484).
- If +24 VDC is not present, go to step 2.

Step 2. Disconnect connector F (3) and check for +24 VDC between wire 638 (1) and ground.

- If +24 VDC is present, repair wiring 638 between connector F and windshield washer pump.
- If +24 VDC is not present, reconnect connector F and go to step 3.

Step 3. Remove defroster nozzle (4) and hose (5).

Step 4. Remove knob (6), nut (7), and windshield wiper/washer switch (8) from dashboard (9).

Step 5. Check for +24 VDC between wire 638 (1) and ground at windshield wiper/washer switch (8).

- If +24 VDC is not present, replace windshield wiper/washer switch (page 4-132).
- If +24 VDC is present, repair wiring 638 between windshield wiper/washer switch and connector F.

Table 3-5. Troubleshooting (Cont)

Malfunction	Test or Inspection	Corrective Action
-------------	--------------------	-------------------

ELECTRICAL SYSTEM (CONT)

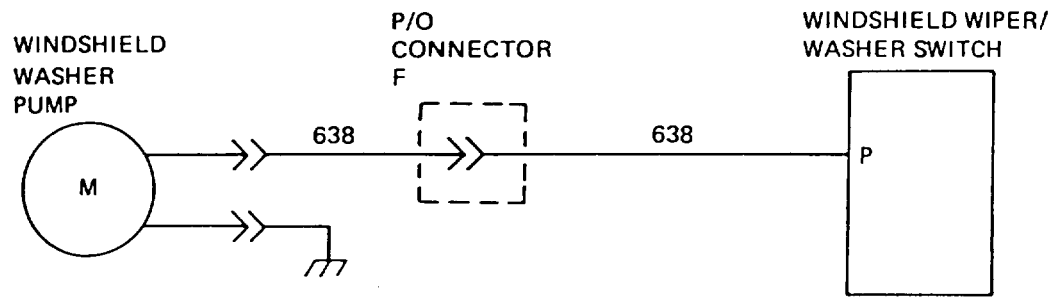
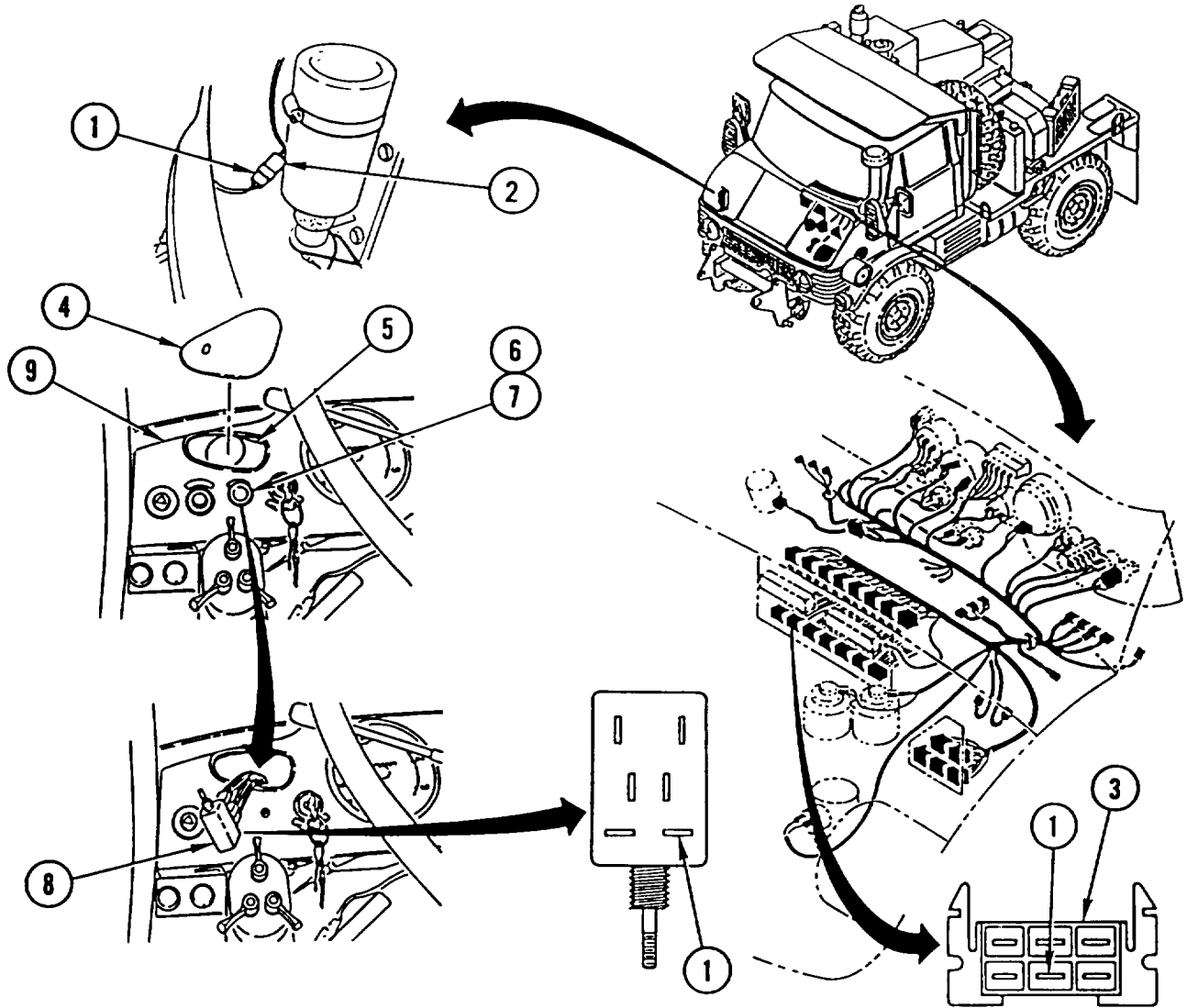

Table 3-5. Troubleshooting (Cont)

Malfunction	Test or Inspection	Corrective Action
-------------	--------------------	-------------------

ELECTRICAL SYSTEM (CONT)

35. WINDSHIELD WIPERS WILL NOT OPERATE.

NOTE

- Vehicle MASTER disconnect switch must be ON, ignition switch set to ON, and windshield wiper/washer switch pulled out once to activate wipers. Failure to do so will cause erroneous results.
- Refer to wiring diagram (page 3-130) for all wiring repair steps.

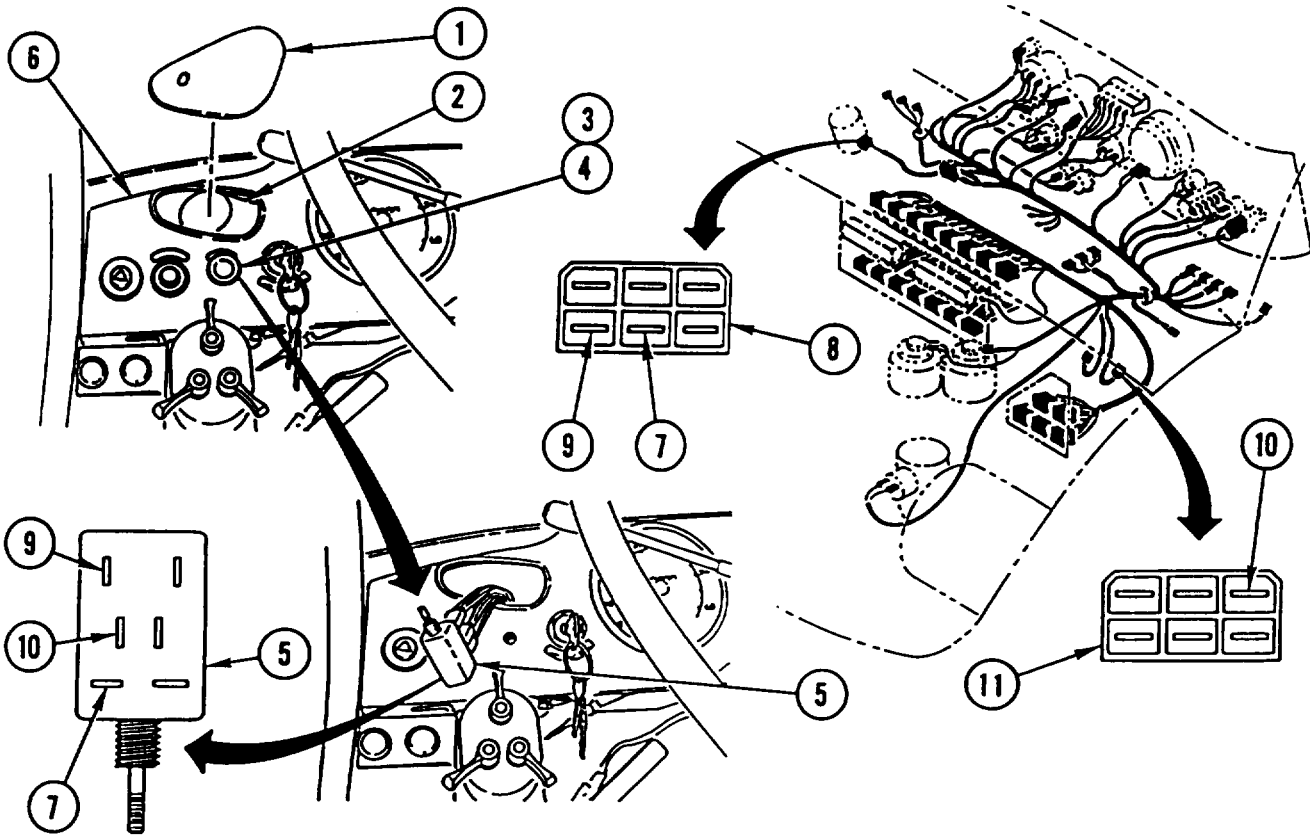

Step 1. Remove defroster nozzle (1) and hose (2).

Step 2. Remove knob (3), nut (4), and windshield wiper/washer switch (5) from dashboard (6).

Table 3-5. Troubleshooting (Cont)

Malfunction	Test or Inspection	Corrective Action
-------------	--------------------	-------------------

ELECTRICAL SYSTEM (CONT)

- Step 3. Check for +24 VDC between wire 632 (7) and ground at windshield wiper/washer switch (5).
- If +24 VDC is not present, repair wiring 63 between windshield wiper/washer switch and fuse box 1.
 - If +24 VDC is present, go to step 4.
- Step 4. Check for +24 VDC between wire 632 (7) and ground at windshield wiper/washer motor connector (8).
- If +24 VDC is not present, repair wiring 632 between windshield wiper/washer motor and windshield wiper/washer switch.
 - If +24 VDC is present, go to step 5.
- Step 5. Check for +24 VDC between wire 631 (9) and ground at windshield wiper/washer switch (5).
- If +24 VDC is not present, replace windshield wiper/washer switch.
 - If +24 VDC is present, go to step 6.
- Step 6. Check for +24 VDC between wire 631 (9) and ground at windshield wiper/washer motor connector (8).
- If +24 VDC is present, replace windshield wiper/washer motor (page 4-477).
 - If +24 VDC is not present, repair wiring 631 between windshield wiper/washer switch and windshield wiper/washer motor. If problem continues, go to step 7.

NOTE

For steps 7 and 8, windshield wiper/washer switch must be pulled out twice to activate delay/intermittent operation.

- Step 7. Check for +24 VDC between wire 635 (10) and ground at windshield wiper/washer switch (5).
- If +24 VDC is not present, replace windshield wiper/washer switch.
 - If +24 VDC is present, go to step 8.
- Step 8. Check for +24 VDC between wire 635 (10) and ground at windshield wiper/washer switch relay connector (11).
- If +24 VDC is present, replace windshield wiper/washer switch relay (page 4-140).
 - If +24 VDC is not present, repair wiring 635.

Table 3-5. Troubleshooting (Cont)

Malfunction	Test or Inspection	Corrective Action
-------------	--------------------	-------------------

ELECTRICAL SYSTEM (CONT)

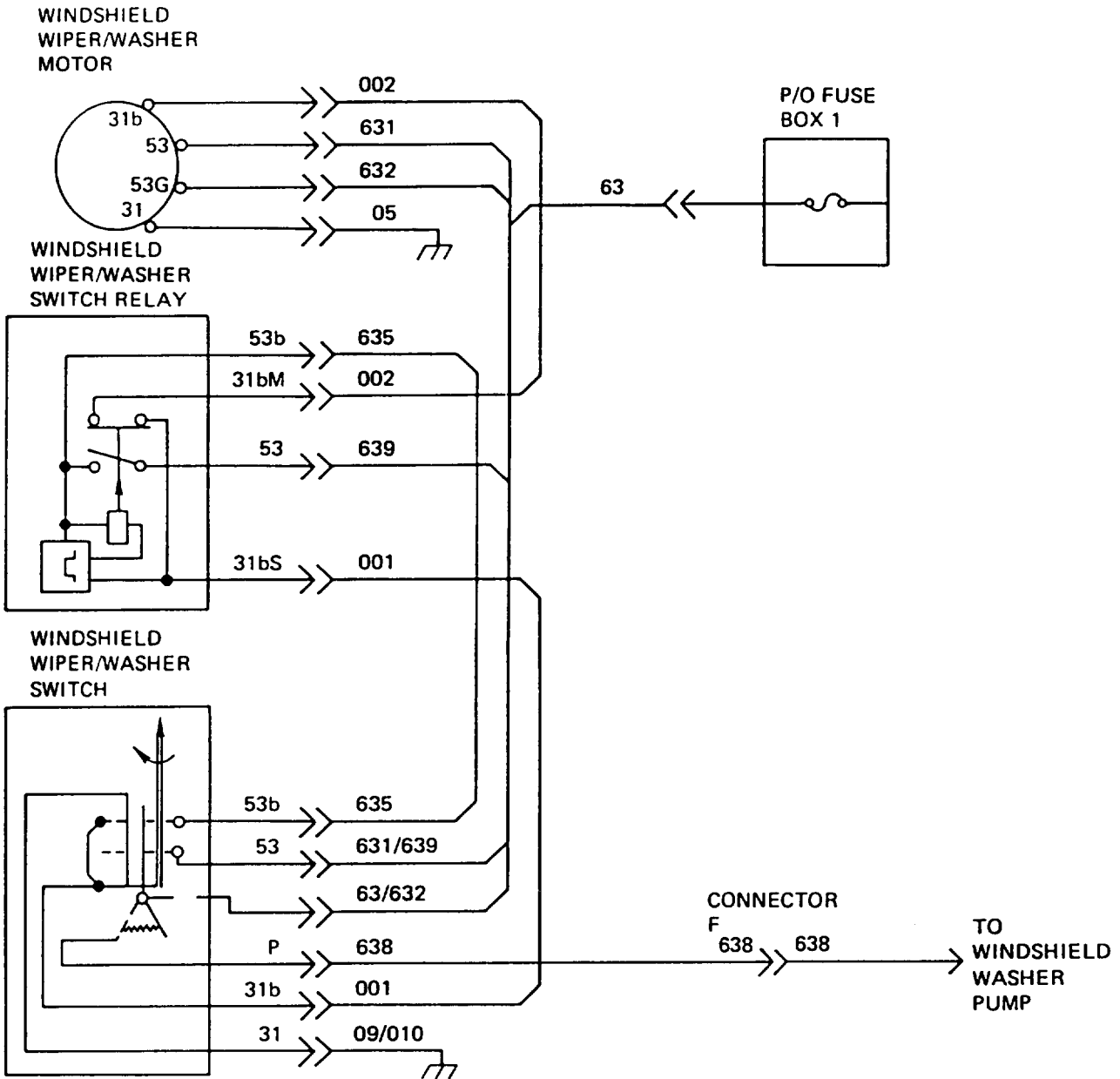

Table 3-5. Troubleshooting (Cont)

Malfunction	Test or Inspection	Corrective Action
-------------	--------------------	-------------------

ELECTRICAL SYSTEM (CONT)

36. DOME LIGHT WILL NOT LIGHT.

NOTE

- Vehicle MASTER disconnect switch must be ON and master light switch set to SER DRIVE. Failure to do so will cause erroneous results.
- Refer to wiring diagram (page 3-132) for all wiring repair steps.

Remove dome light (1) and check for +24 VDC between wire 43 (2) and ground at dome light.

- If +24 VDC is present, replace two lamps (3).
- If +24 VDC is not present, repair wiring 43 between dome light and fuse box 1.

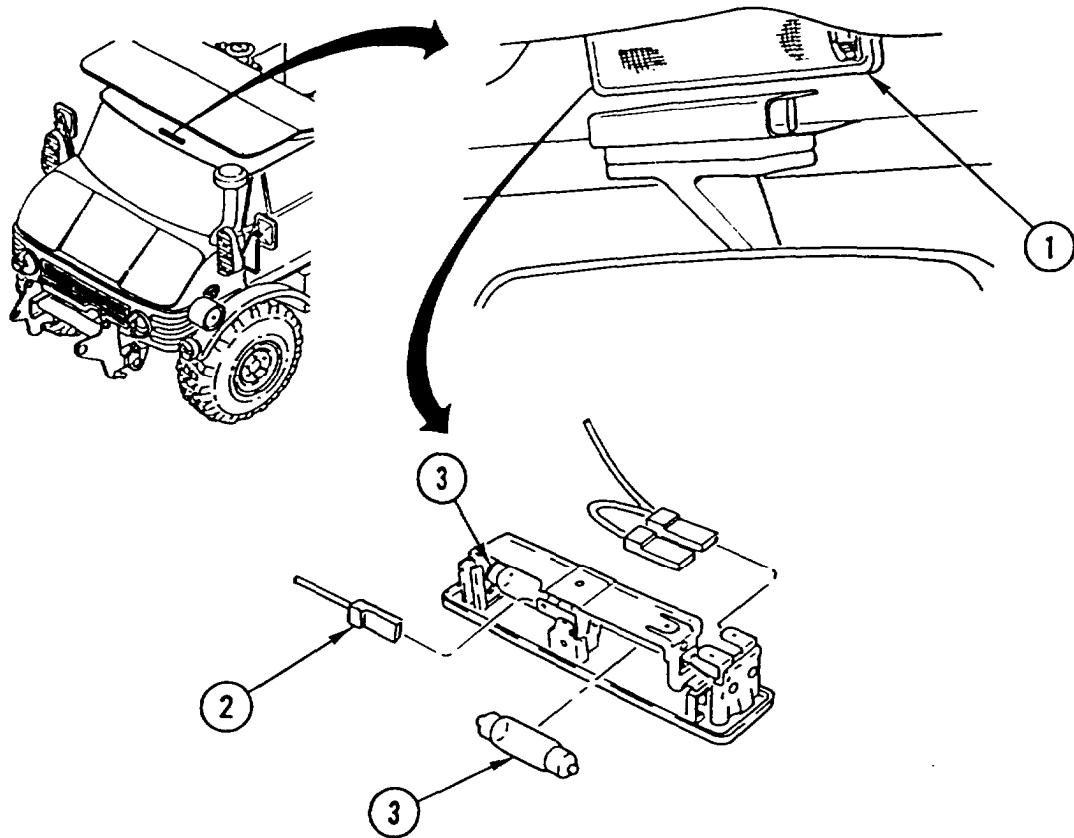

Table 3-5. Troubleshooting (Cont)

Malfunction

Test or Inspection

Corrective Action

ELECTRICAL SYSTEM (CONT)

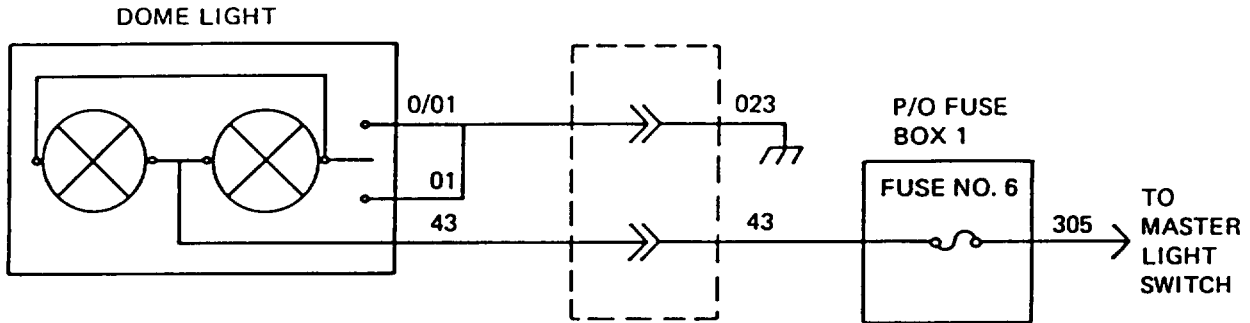

Table 3-5. Troubleshooting (Cont)

Malfunction	Test or Inspection	Corrective Action
-------------	--------------------	-------------------

ELECTRICAL SYSTEM (CONT)

37. CAB HEATER FAN WILL NOT OPERATE.

NOTE

- Vehicle MASTER disconnect switch must be ON and ignition switch set to ON.
- Failure to do so will cause erroneous results.

Refer to wiring diagram for all wiring repair steps.

Step 1. Remove clamp (1) and pipe (2).

Step 2. Disconnect connector AE (3) and check for +24 VDC between wire 61 (4) and ground.

- If +24 VDC is present, replace cab heater (page 4-490).
- If +24 VDC is not present, repair wiring 61 between cab heater and fuse box 1.

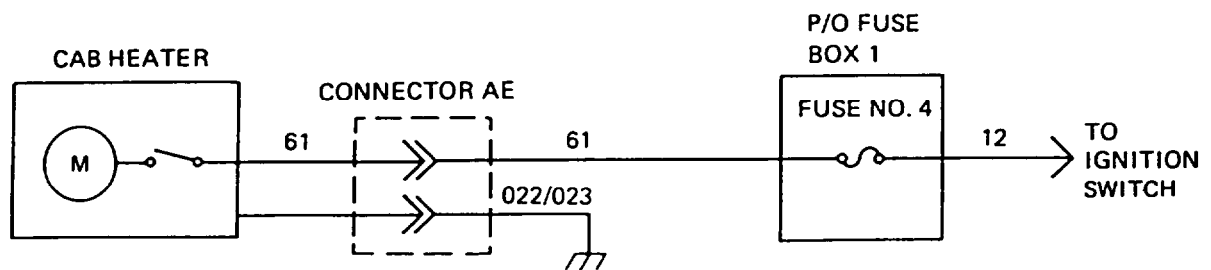
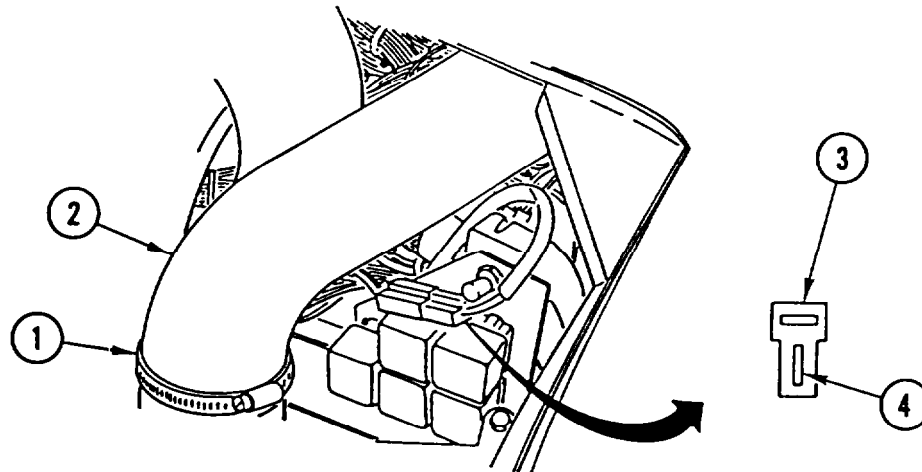

Table 3-5. Troubleshooting (Cont)

Malfunction

Test or Inspection

Corrective Action

ELECTRICAL SYSTEM (CONT)

38. PANEL LIGHTS WILL NOT LIGHT.

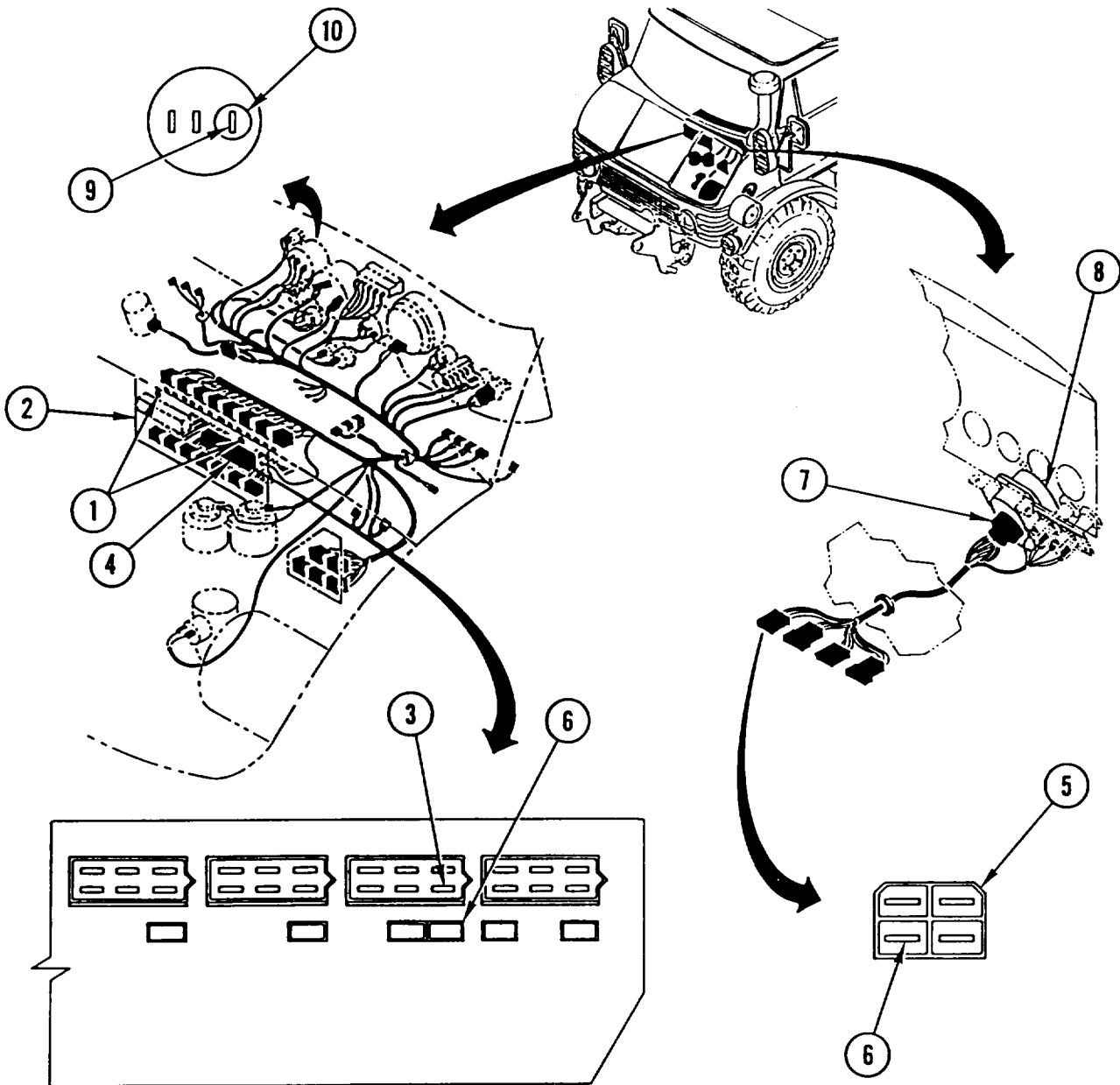

Table 3-5. Troubleshooting (Cont)

Malfunction	Test or Inspection	Corrective Action
-------------	--------------------	-------------------

ELECTRICAL SYSTEM (CONT)

NOTE

- Vehicle MASTER disconnect switch must be ON and master light switch set to PANEL BRT. Failure to do so will cause erroneous results.
- Refer to wiring diagram (page 3-136) for all wiring repair steps.

Step 1. Check that all panel lights are lit.

- If only speedometer light is not lit, replace speedometer lamp (page 4-727).
- If only tachometer light is not lit, replace tachometer lamp (page 4-128).
- If only indicator (gage) light is not lit, replace indicator (gage) lamp (page 4-124).
- If tachometer light, indicator (gage) light, and ammeter (voltmeter) light are not lit, repair wiring 492 between speedometer and tachometer.
- If indicator (gage) light and ammeter (voltmeter) light are not lit, repair wiring 493 between tachometer and indicator (gage).
- If only ammeter (voltmeter) light is not lit, go to step 6.
- If no lights are lit, go to step 2.

Step 2. Loosen two captive screws (1) and pull bracket (2) out enough to gain access to area behind bracket.

Step 3. Check for +24 VDC between wire 491 (3) and ground at fuse box 1 (4).

- If +24 VDC is present, repair wiring 491 between fuse box 1 and speedometer.
- If +24 VDC is not present, go to step 4.

Step 4. Disconnect connector K (5) and check for +24 VDC between wire 49 (6) and ground.

- If +24 VDC is present, repair wiring 49 between connector K and fuse box 1.
- If +24 VDC is not present, reconnect connector K and go to step 5.

Table 3-5. Troubleshooting (Cont)

Malfunction	Test or Inspection	Corrective Action
-------------	--------------------	-------------------

ELECTRICAL SYSTEM (CONT)

- Step 5. Disconnect master light switch connector (7) and check for continuity between terminal A and terminal B of master light switch (8).
- If there is continuity, repair wiring 49 between master light switch and connector K.
 - If there is no continuity, replace master light switch (page 4-137).
- Step 6. Check for +24 VDC between wire 494 (9) and ground at ammeter (voltmeter) (10).
- If +24 VDC is present, replace ammeter (page 4-135).
 - If +24 VDC is not present, repair wiring 494 between indicator (gauge) and ammeter.

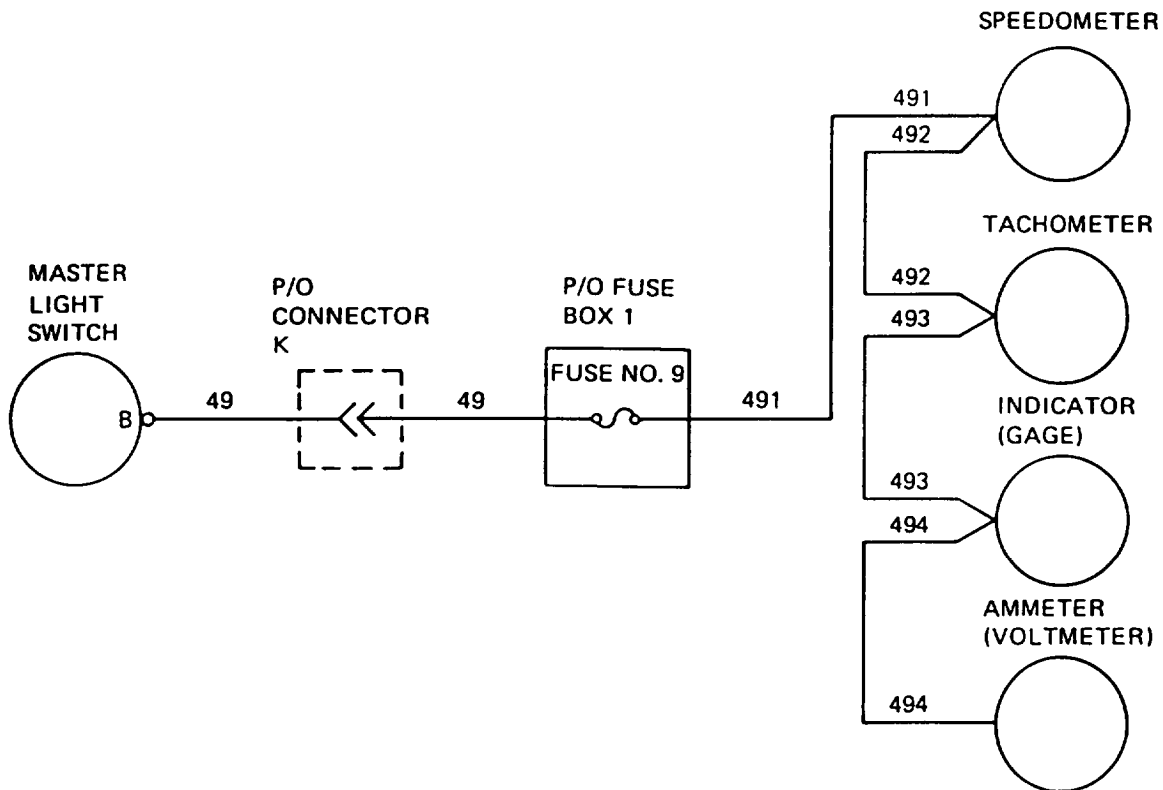

Table 3-5. Troubleshooting (Cont)

Malfunction	Test or Inspection	Corrective Action
ELECTRICAL SYSTEM (CONT)		
39. TACHOMETER SHOWS NO INDICATION.		
NOTE		
<ul style="list-style-type: none"> • If STE/ICE-R CI Engine GO-NO GO Chain does not diagnose cause of problem, return to this troubleshooting table. • Refer to wiring diagram (page 3-138) for all wiring repair steps. 		
<p>Step 1. Perform STE/ICE-R CI Engine GO-NO GO Chain test procedures in the DCA diagnostic mode.</p> <ul style="list-style-type: none"> • If malfunction is found, refer to List of Tasks (page iii) or Alphabetical Index (page Index-1) and repair or replace damaged or faulty components. • If malfunction is not found, go to step 2. 		
<p>Step 2. Loosen two captive screws (1) and pull bracket (2) out enough to gain access to area behind bracket.</p>		
<p>Step 3. Remove two clamps (3) and pipe assembly (4).</p>		
NOTE		
For steps 4 thru 6, engine must be running.		
<p>Step 4. Check for +24 VDC between wire 31S (5) and ground at tachometer (6).</p> <ul style="list-style-type: none"> • If +24 VDC is present, go to step 6. • If +24 VDC is not present, go to step 5. 		
<p>Step 5. Disconnect connector D (7) and check for +24 VDC between wire 31S (5) and ground.</p> <ul style="list-style-type: none"> • If +24 VDC is not present, repair wiring 31S between connector D and alternator. • If +24 VDC is present, repair wiring 31S between tachometer and connector D. 		
<p>Step 6. Check for +24 VDC between wire 36 (8) and ground at tachometer (6).</p> <ul style="list-style-type: none"> • If +24 VDC is present, replace tachometer (page 4-128). • If +24 VDC is not present, repair wiring 36 between tachometer and fuse box 1. 		

Table 3-5. Troubleshooting (Cont)

Malfunction	Test or Inspection	Corrective Action
-------------	--------------------	-------------------

ELECTRICAL SYSTEM (CONT)

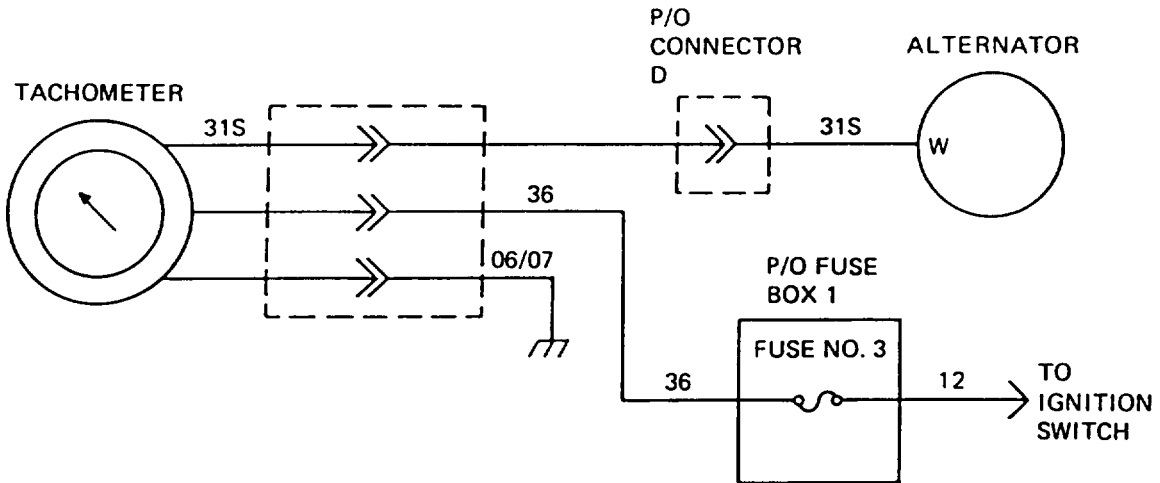
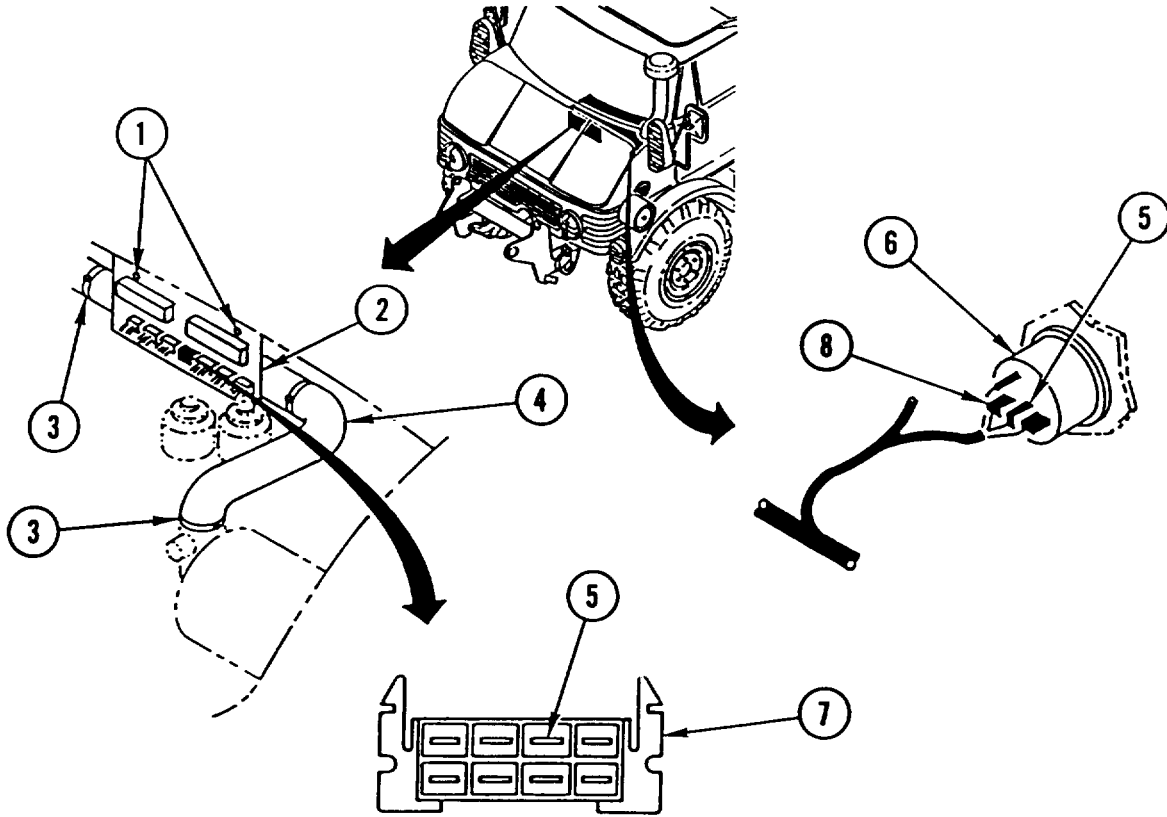

Table 3-5. Troubleshooting (Cont)

Malfunction	Test or Inspection	Corrective Action
-------------	--------------------	-------------------

ELECTRICAL SYSTEM (CONT)

40. LOW PRESSURE WARNING BUZZER WILL NOT SOUND.

NOTE

- Vehicle MASTER disconnect switch must be ON, ignition switch set to ON, and air pressure relieved. Failure to do so will cause erroneous results.
- Refer to wiring diagram for all wiring repair steps.

Check for +24 VDC between wire 33 (1) and ground at low pressure warning buzzer (2).

- If +24 VDC is present, disconnect connector (3) and replace low pressure warning buzzer.
- If +24 VDC is not present, repair wiring 33 between indicator (gauge) and low pressure warning buzzer.

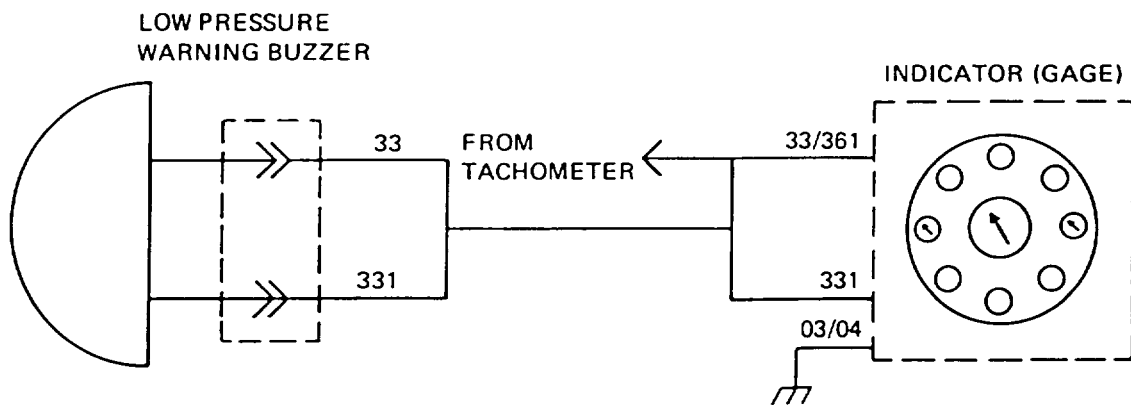
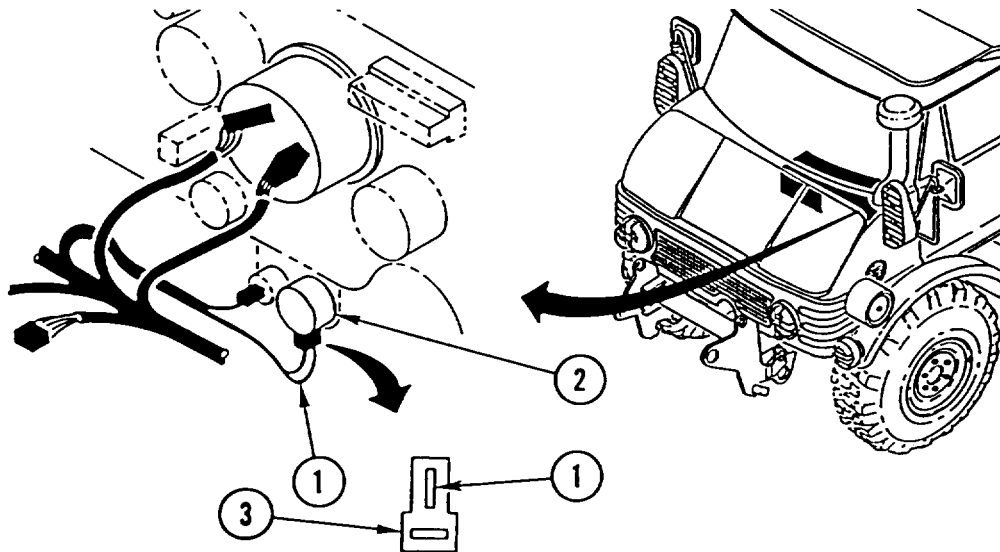

Table 3-5. Troubleshooting (Cont)

Malfunction	Test or Inspection	Corrective Action
-------------	--------------------	-------------------

ELECTRICAL SYSTEM (CONT)

41. TURN SIGNAL INDICATOR LIGHT WILL NOT LIGHT.

NOTE

- Vehicle MASTER disconnect switch must be ON, master light switch set to SER DRIVE, and ignition switch set to ON. Place turn signal lever in position in which failure occurred. Failure to do so will cause erroneous results.
- Refer to wiring diagram for all wiring repair steps.

Step 1. Loosen two captive screws (1) and pull bracket (2) out enough to gain access to area behind bracket.

Step 2. Remove two clamps (3) and pipe assembly (4).

Step 3. Check for +24 VDC between wire 391 (5) and ground at indicator (gage) (6).

- If +24 VDC is present, replace turn signal indicator lamp (7).
- If +24 VDC is not present, go to step 4.

Step 4. Check for +24 VDC between wire 391 (5) and ground at turn signal flasher relay (8).

- If +24 VDC is not present, replace turn signal flasher relay (page 4-196).
- If +24 VDC is present, repair wiring 391.

Table 3-5. Troubleshooting (Cont)

Malfunction	Test or Inspection	Corrective Action
-------------	--------------------	-------------------

ELECTRICAL SYSTEM (CONT)

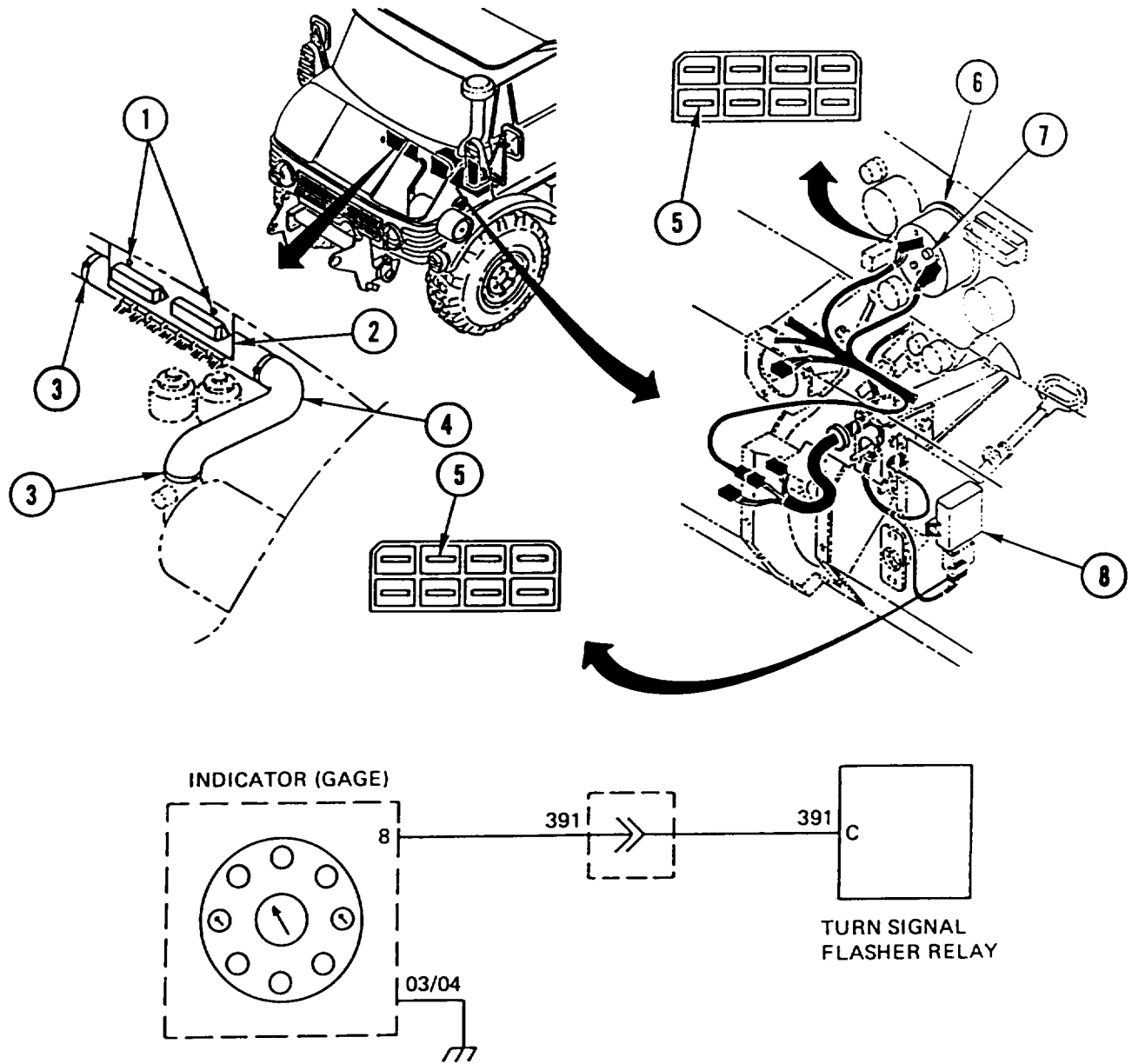

Table 3-5. Troubleshooting (Cont)

Malfunction	Test or Inspection	Corrective Action
-------------	--------------------	-------------------

ELECTRICAL SYSTEM (CONT)

42. HIGH BEAM INDICATOR LIGHT WILL NOT LIGHT.

NOTE

- Vehicle MASTER disconnect switch must be ON, master light switch set to SER DRIVE, and horn, low beam/high beam switch set to HI. Failure to do so will cause erroneous results.
- Refer to wiring diagram for all wiring repair steps.
 - Step 1. Loosen two captive screws (1) and pull bracket (2) out enough to gain access to area behind bracket.
 - Step 2. Remove two clamps (3) and pipe assembly (4).
 - Step 3. Check for +24 VDC between wire 41HL1 (5) and ground at indicator (gage) (6).
 - If +24 VDC is present, replace high beam indicator lamp (7).
 - If +24 VDC is not present, repair wiring 41HL1.

Table 3-5. Troubleshooting (Cont)

Malfunction	Test or Inspection	Corrective Action
-------------	--------------------	-------------------

ELECTRICAL SYSTEM (CONT)

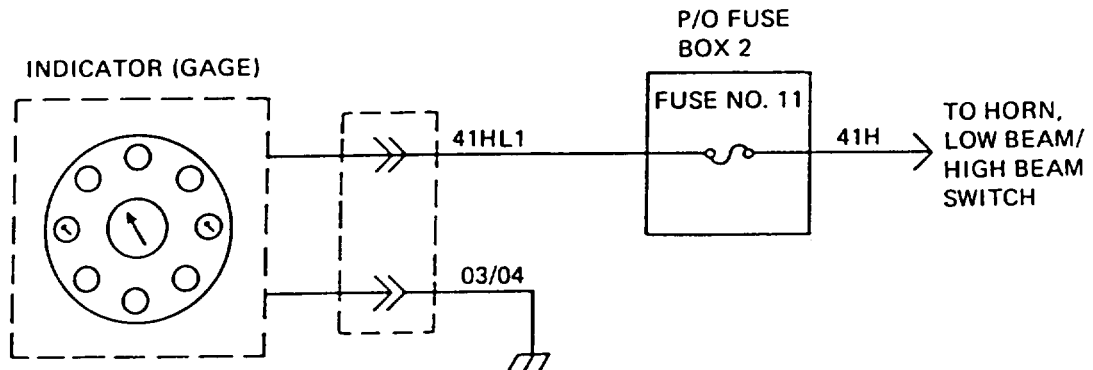
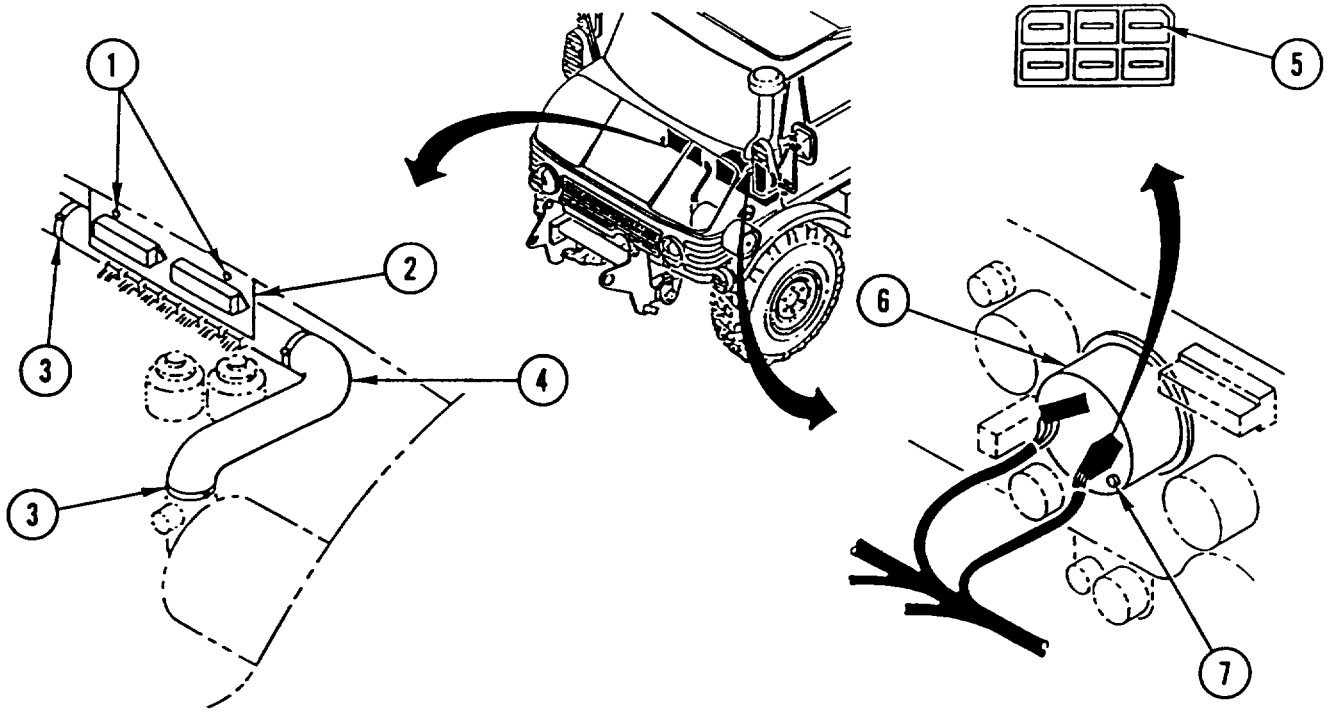

Table 3-5. Troubleshooting (Cont)

Malfunction	Test or Inspection	Corrective Action
-------------	--------------------	-------------------

ELECTRICAL SYSTEM (CONT)

43. CHARGE INDICATOR LIGHT STAYS ON DURING OPERATION.

NOTE

- If STE/ICE-R CI Engine GO-NO GO Chain does not diagnose cause of problem, return to this troubleshooting table.
- Refer to wiring diagram for all wiring repair steps.

Step 1. Perform STE/ICE-R CI Engine GO-NO GO Chain test procedures in the DCA diagnostic mode.

- If malfunction is found, refer to List of Tasks (page iii) or Alphabetical Index (page Index-1) and repair or replace damaged or faulty components.
- If malfunction is not found, go to step 2.

NOTE

For steps 2 and 3, engine must be running.

Step 2. Disconnect connector D (1) and check for +24 VDC between wire 34 (2) and ground.

- If +24 VDC is present, repair wiring 34 between connector D and indicator (gage).
- If +24 VDC is not present, reconnect connector D and go to step 3.

Step 3. Check for +24 VDC between wire 34 (2) and ground at suppressor filter (3).

- If +24 VDC is not present, replace suppressor filter (page 4-235).
- If +24 VDC is present, repair wiring 34 between connector D and suppressor filter.

Table 3-5. Troubleshooting (Cont)

Malfunction	Test or Inspection	Corrective Action
-------------	--------------------	-------------------

ELECTRICAL SYSTEM (CONT)

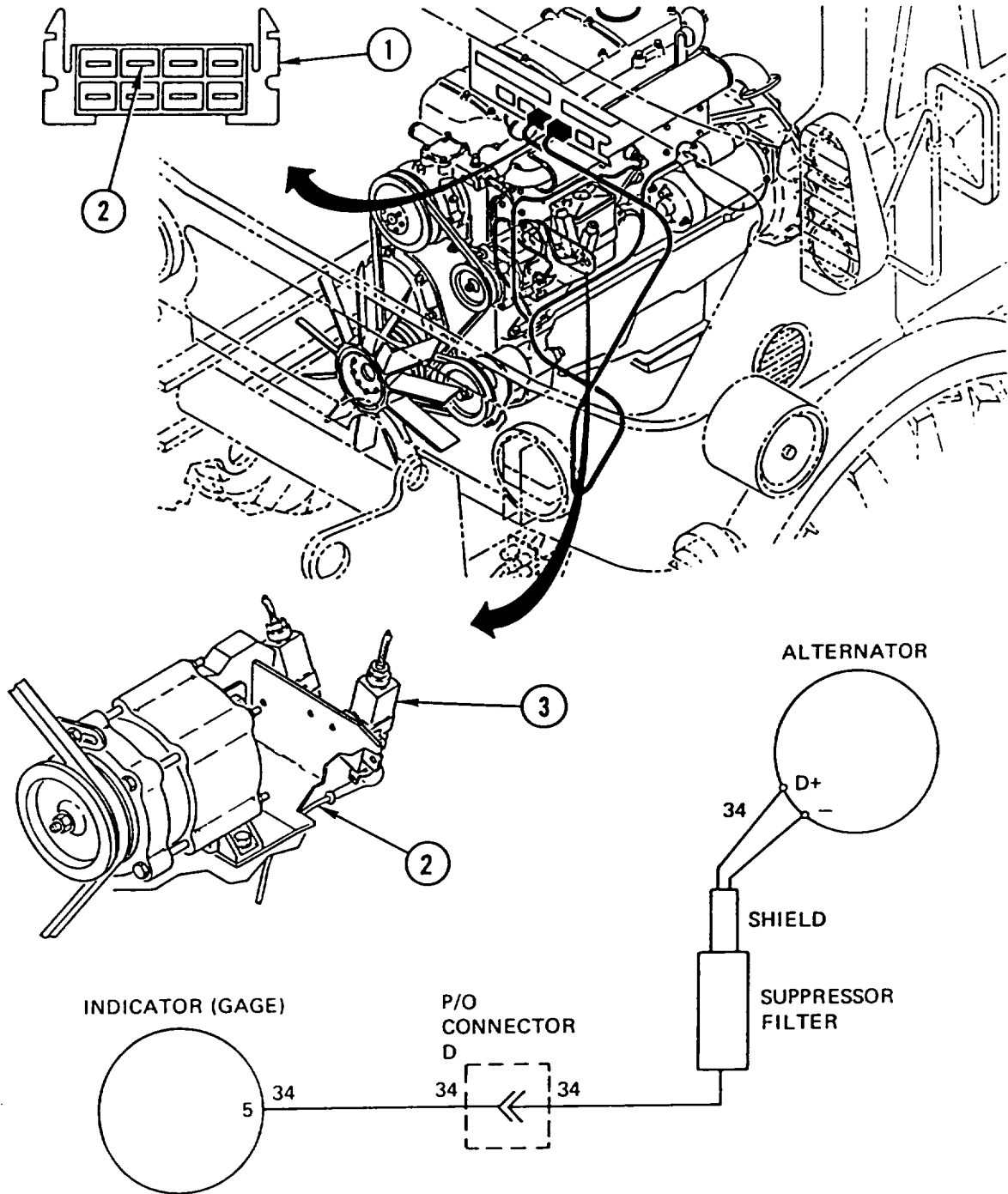

Table 3-5. Troubleshooting (Cont)

Malfunction	Test or Inspection	Corrective Action
-------------	--------------------	-------------------

ELECTRICAL SYSTEM (CONT)

44. WATER TEMPERATURE GAGE SHOWS NO INDICATION.

NOTE

- Resistance will vary depending on water temperature.
- Refer to wiring diagram for all wiring repair steps.

Step 1. Disconnect wire 31T (1) from water temperature sending unit (2) and check for resistance between terminal (3) and shell of water temperature sending unit (2).

- If there is no resistance, replace water temperature sending unit (page 4-203).
- If there is resistance, go to step 2.

Step 2. With wire 31T (1) disconnected from water temperature sending unit (2), check for +24 VDC between wire 31T and ground at water temperature sending unit.

- If +24 VDC is present, replace water temperature sending unit (page 4-203).
- If +24 VDC is not present, go to step 3.

Step 3. With wire 31T (1) disconnected from water temperature sending unit, check for +24 VDC between wire 31T and ground at connector D (4).

- If +24 VDC is present, repair wiring 31T between connector D and water temperature sending unit.
- If +24 VDC is not present, go to step 4.

Step 4. Loosen two captive screws (5) and pull bracket (6) out enough to gain access to area behind bracket.

Step 5. Remove two clamps (7) and pipe assembly (8).

Step 6. With wire 31T (1) disconnected from water temperature sending unit, check for +24 VDC between wire 31T and ground at indicator (gage) (9).

- If +24 VDC is not present, reconnect wire 31T at water temperature sending unit and replace indicator (gage) (page 4-124).
- If +24 VDC is present, reconnect wire 31T at water temperature sending unit and repair wiring 31T between indicator (gage) and connector D.

Table 3-5. Troubleshooting (Cont)

Malfunction	Test or Inspection	Corrective Action
-------------	--------------------	-------------------

ELECTRICAL SYSTEM (CONT)

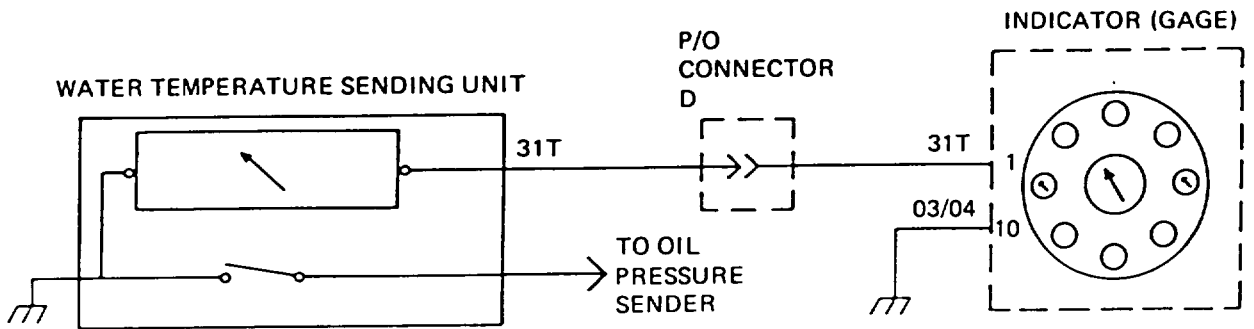
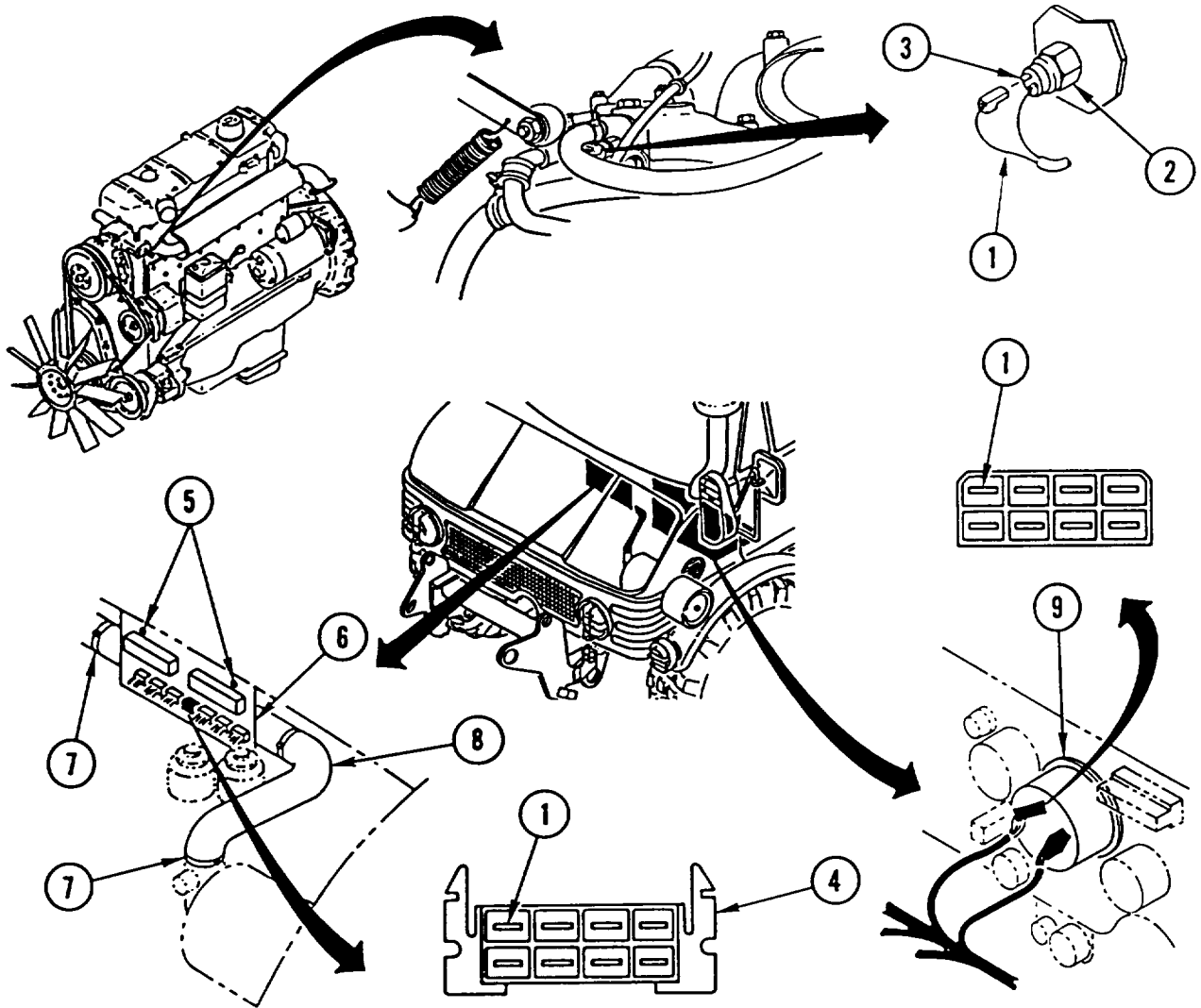

Table 3-5. Troubleshooting (Cont)

Malfunction	Test or Inspection	Corrective Action
-------------	--------------------	-------------------

ELECTRICAL SYSTEM (CONT)

45. FUEL LEVEL GAGE SHOWS NO INDICATION.

W A R N I N G

Diesel fuel is flammable. Do not perform this procedure near fire, flame, or sparks. Injury or death to personnel could result.

NOTE

Refer to wiring diagram for all wiring repair steps.

Step 1. Remove nut (1) and lock washer (2). Disconnect wire 30 (3) from fuel level gage (4) and check for +24 VDC between wire 30 and ground.

- If +24 VDC is present, replace fuel level gage (page 4-204).
- If +24 VDC is not present, go to step 2.

Step 2. With wire 30 (3) disconnected from fuel level gage, disconnect connector C (5) and check for +24 VDC between wire 30 and ground.

- If +24 VDC is present, repair wiring 30 between fuel level gage and connector C.
- If +24 VDC is not present, reconnect connector C and go to step 3.

Step 3. Loosen two captive screws (6) and pull bracket (7) out enough to gain access to area behind bracket.

Step 4. Remove two clamps (8) and pipe assembly (9).

Step 5. With wire 30 (3) disconnected from fuel level gage, check for +24 VDC between wire 30 and ground at indicator (gage) (10).

- If +24 VDC is not present, reconnect wire 30 at fuel level gage and replace indicator (gage) (page 4-124).
- If +24 VDC is present, reconnect wire 30 at fuel level gage and repair wiring 30 between connector C and indicator (gage).

Table 3-5. Troubleshooting (Cont)

Malfunction	Test or Inspection	Corrective Action
-------------	--------------------	-------------------

ELECTRICAL SYSTEM (CONT)

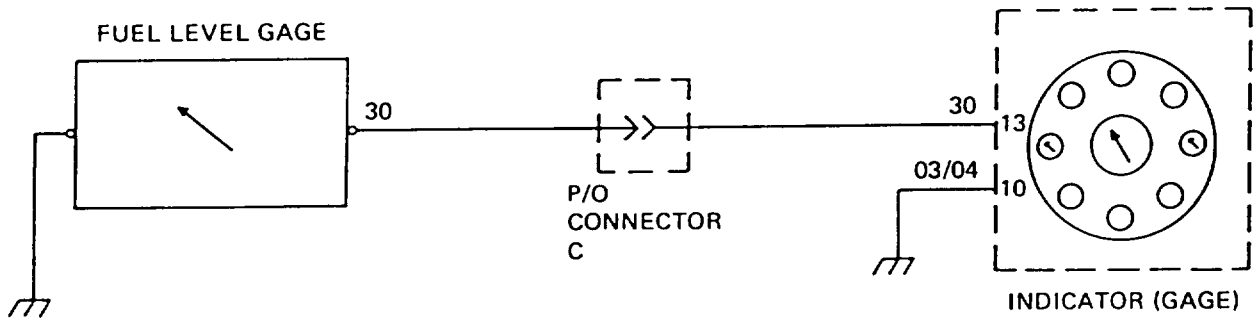
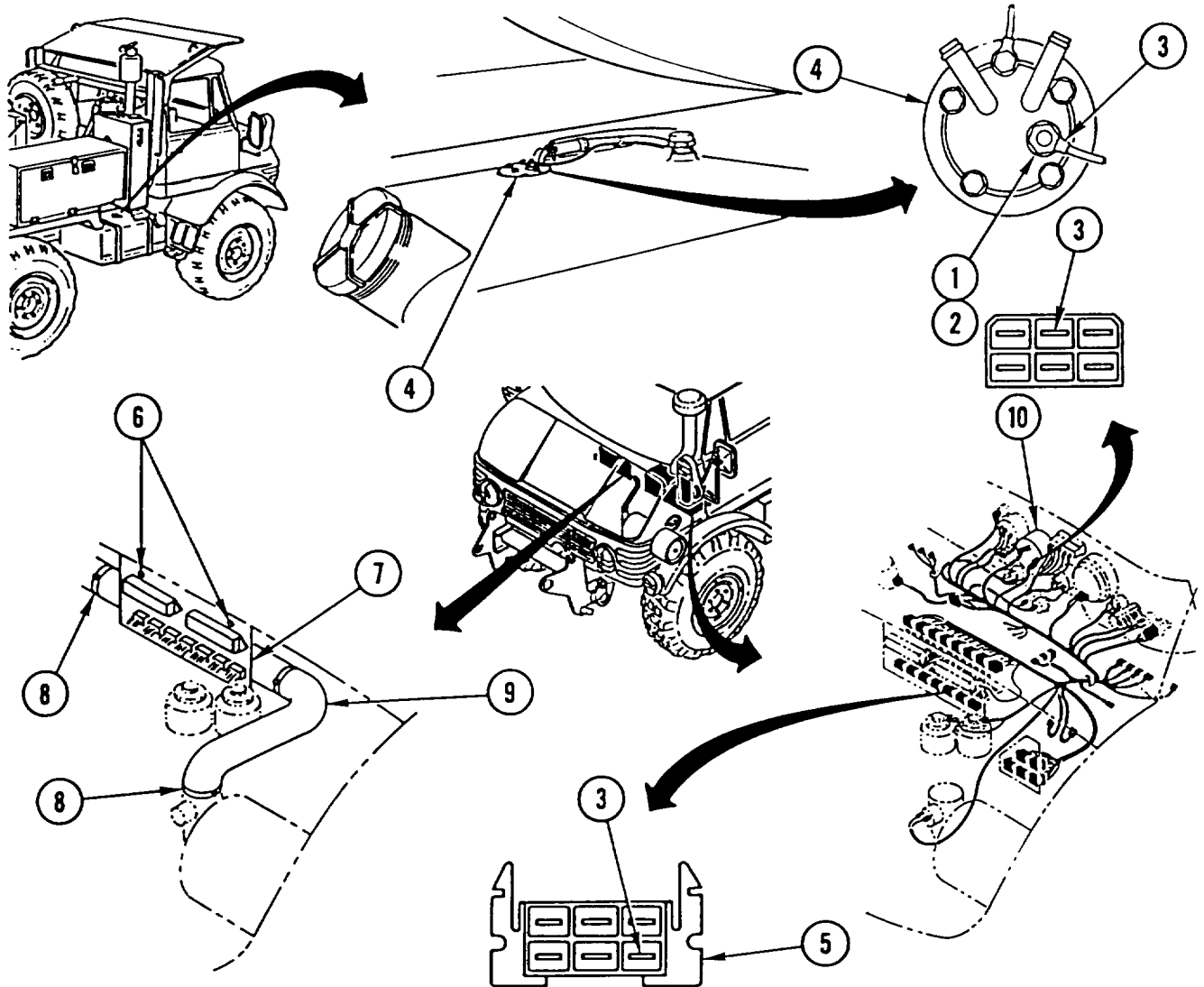

Table 3-5. Troubleshooting (Cont)

Malfunction	Test or Inspection	Corrective Action
-------------	--------------------	-------------------

ELECTRICAL SYSTEM (CONT)

46. AMMETER (VOLTMETER) SHOWS NO INDICATION.

NOTE

- Vehicle MASTER disconnect switch must be ON and ignition switch set to ON. Failure to do so will cause erroneous results.
- Refer to wiring diagram for all wiring repair steps.

Step 1. Loosen two captive screws (1) and pull bracket (2) out enough to gain access to area behind bracket.

Step 2. Remove two clamps (3) and pipe assembly (4).

Step 3. Check for +24 VDC between wire 121 (5) and ground at ammeter (voltmeter) (6).

- If +24 VDC is present, replace ammeter (page 4-135).
- If +24 VDC is not present, repair wiring 121 between ammeter and ignition switch.

Table 3-5. Troubleshooting (Cont)

Malfunction	Test or Inspection	Corrective Action
-------------	--------------------	-------------------

ELECTRICAL SYSTEM (CONT)

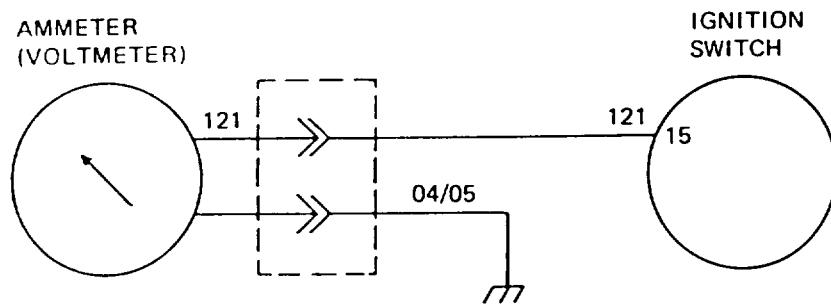
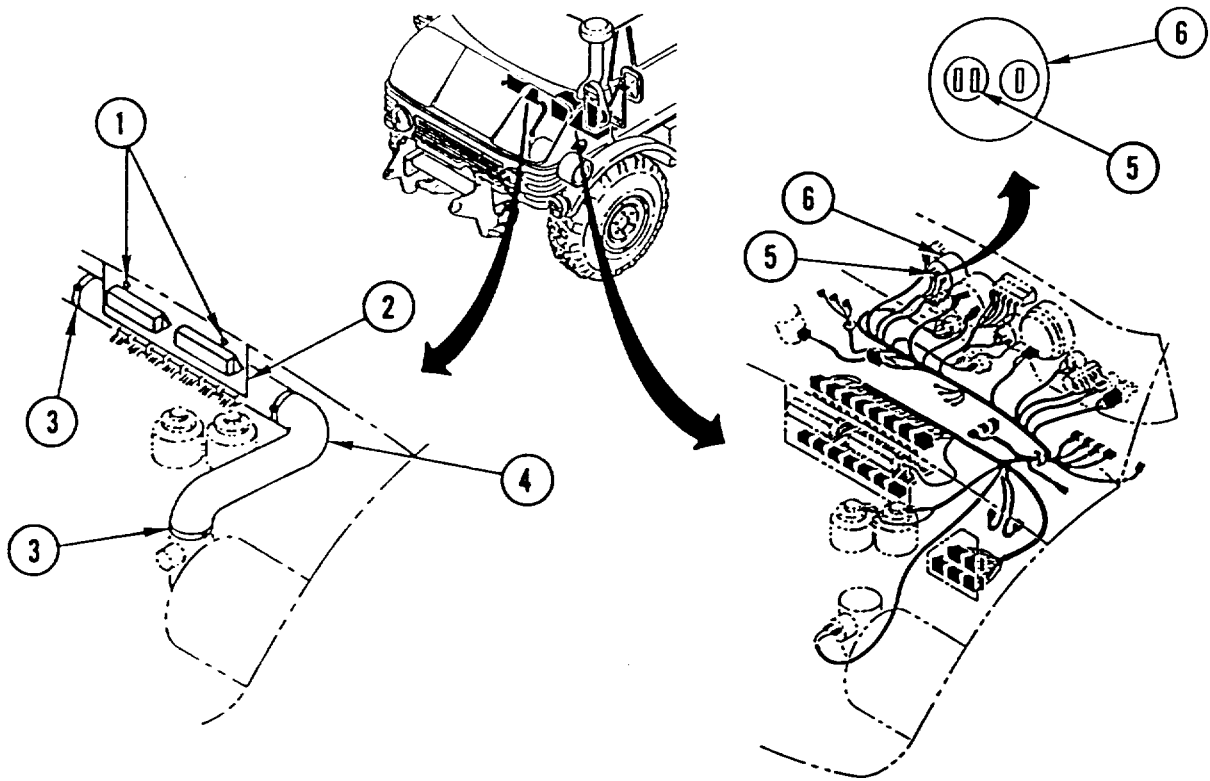

Table 3-5. Troubleshooting (Cont)

Malfunction	Test or inspection	Corrective Action
-------------	--------------------	-------------------

Electrical SYSTEM (CONT)

47. COLD START SYSTEM WILL NOT OPERATE.

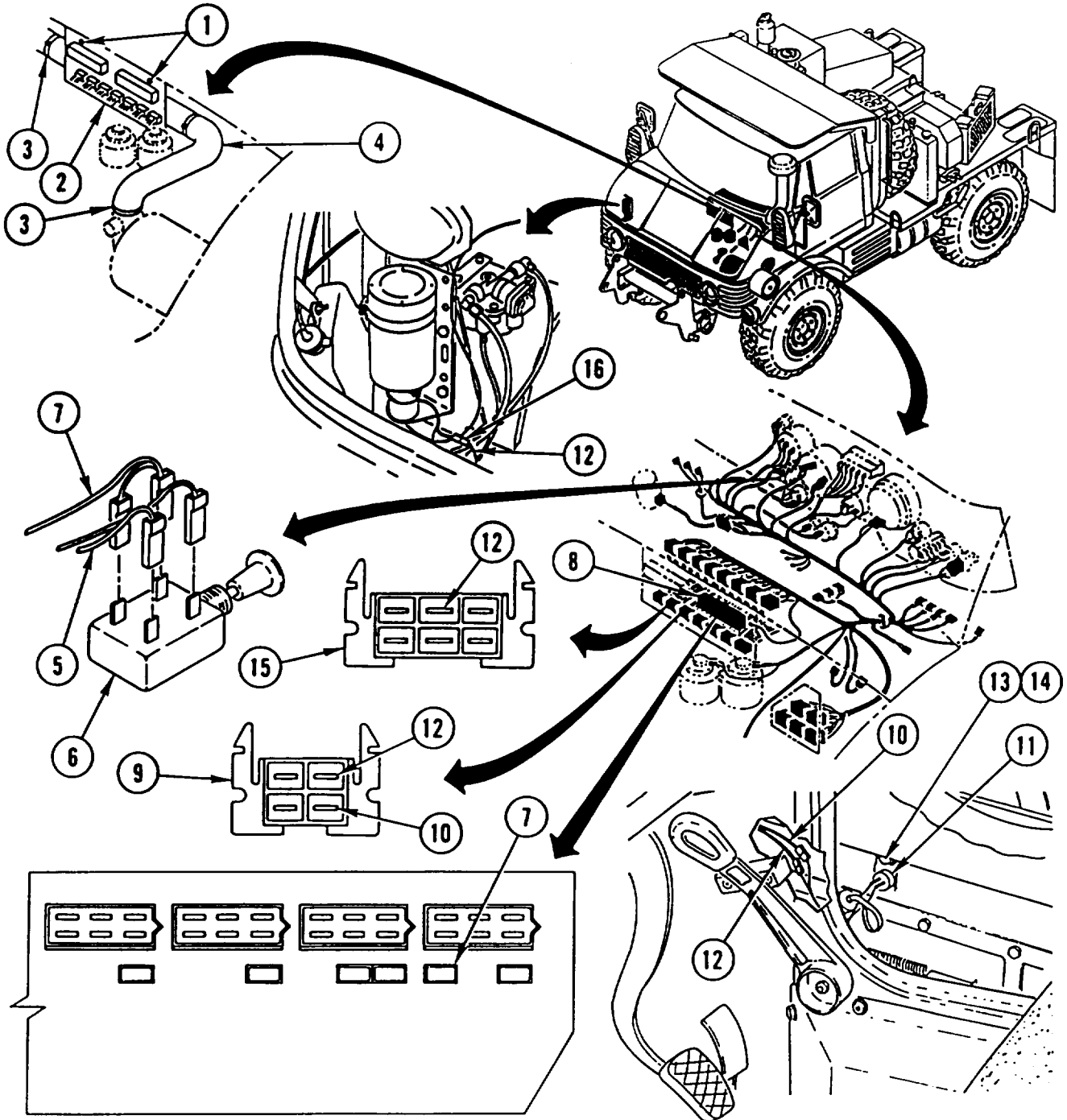

Table 3-5. Troubleshooting (Cont)

Malfunction	Test or Inspection	Corrective Action
ELECTRICAL SYSTEM (CONT)		
NOTE		
		<ul style="list-style-type: none"> • Vehicle MASTER disconnect switch must be ON and ignition switch set to ON. Failure to do so will cause erroneous results. • Engine temperature must be below 32°F (0°C) and starter switch must be depressed for cold start system to operate. • Refer to wiring diagram (page 3-155) for all wiring repair steps. <ul style="list-style-type: none"> Step 1. Check ether supply bottle. <ul style="list-style-type: none"> • If ether supply bottle is empty, replace bottle (page 4-55). • If ether supply bottle is not empty, go to step 2. Step 2. Loosen two captive screws (1) and pull bracket (2) out enough to gain access to area behind bracket. Step 3. Remove two clamps (3) and pipe assembly (4). Step 4. Check for +24 VDC between wire 28 (5) and ground at cold start switch (6). <ul style="list-style-type: none"> • If +24 VDC is not present, repair wiring 28 between cold start switch and starter switch. • If +24 VDC is present, go to step 5. Step 5. Engage cold start switch (6) and check for +24 VDC between wire 283 (7) and ground at cold start switch. <ul style="list-style-type: none"> • If +24 VDC is not present, replace cold start switch (page 4-136). • If +24 VDC is present, go to step 6. Step 6. Check for +24 VDC between wire 283 (7) and ground at fuse box 1 (8). <ul style="list-style-type: none"> • If +24 VDC is not present, repair wiring 283 between fuse box 1 and cold start switch. • If +24 VDC is present, go to step 7. Step 7. Disconnect connector E (9) and check for +24 VDC between wire 284 (10) and ground. <ul style="list-style-type: none"> • If +24 VDC is not present, repair wiring 284 between connector E and fuse box 1. • If +24 VDC is present, reconnect connector E and go to step 8.

Table 3-5. Troubleshooting (Cont)

Malfunction	Test or Inspection	Corrective Action
ELECTRICAL SYSTEM (CONT)		
Step 8.	Check for +24 VDC between wire 284 (10) and ground at engine temperature switch (11).	<ul style="list-style-type: none"> • If +24 VDC is not present, repair wiring 284 between engine temperature switch and connector E. • If +24 VDC is present, go to step 9.
Step 9.	Check for +24 VDC between wire 286 (12) and ground at engine temperature switch (11).	<ul style="list-style-type: none"> • If +24 VDC is not present, remove screw (13) and lock washer (14) and replace engine temperature switch (11). • If +24 VDC is present, go to step 10.
Step 10.	Disconnect connector E (9) and check for +24 VDC between wire 286 (12) and ground.	<ul style="list-style-type: none"> • If +24 VDC is not present, repair wiring 286 between connector E and engine temperature switch. • If +24 VDC is present, reconnect connector E and go to step 11.
Step 11.	Disconnect connector F (15) and check for +24 VDC between wire 286 (12) and ground.	<ul style="list-style-type: none"> • If +24 VDC is not present, repair wiring 286 between connector F and engine temperature switch. • If +24 VDC is present, reconnect connector F and go to step 12.
Step 12.	Disconnect connector W (16) and check for +24 VDC between wire 286 (12) and ground.	<ul style="list-style-type: none"> • If +24 VDC is present, replace cold start aid (page 4-55). • If +24 VDC is not present, repair wiring 286 between connector W and connector F.

Table 3-5. Troubleshooting (Cont)

Malfunction	Test or Inspection	Corrective Action
-------------	--------------------	-------------------

ELECTRICAL SYSTEM (CONT)

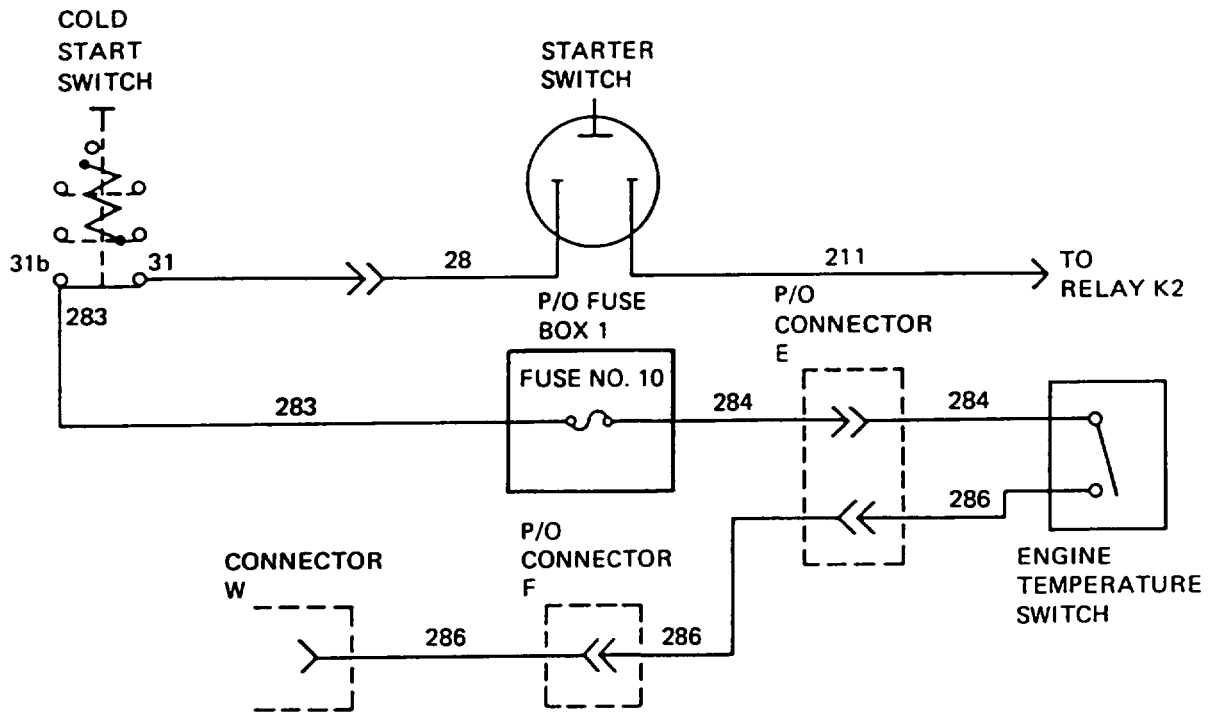

Table 3-5. Troubleshooting (Cont)

Malfunction	Test or Inspection	Corrective Action
ELECTRICAL SYSTEM (CONT)		
48. DRIVER SIDE WINDSHIELD HEATER WILL NOT OPERATE.		
NOTE		
Refer to wiring diagram (page 3-159) for all wiring repair steps.		
	Step 1. Pull windshield heater control switch 1 (1) and verify lamp (2) is lit.	<ul style="list-style-type: none"> • If lamp is lit, go to step 4. • If lamp is not lit, go to step 2.
	Step 2. Check for +24 VDC between wire 623 (3) and ground at windshield heater control switch 1 (1).	<ul style="list-style-type: none"> • If +24 VDC is present, replace lamp (2) and go to step 4. • If +24 VDC is not present, go to step 3.
	Step 3. Disconnect connector N (4) and check for +24 VDC between wire 623 (3) and ground.	<ul style="list-style-type: none"> • If +24 VDC is present, repair wiring 623 between connector N and windshield heater control switch 1. • If +24 VDC is not present, repair wiring 623 between connector N and cab heater.
	Step 4. Check for +24 VDC between wire 624 (5) and ground at windshield heater control switch 1 (1).	<ul style="list-style-type: none"> • If +24 VDC is not present, replace windshield heater control switch 1 (page 4-139). • If +24 VDC is present, go to step 5.
	Step 5. Disconnect connector N (4) and check for +24 VDC between wire 624 (5) and ground.	<ul style="list-style-type: none"> • If +24 VDC is present, repair wiring 624 between connector N and windshield heater control switch 1. • If +24 VDC is not present, reconnect connector N and go to step 6.
	Step 6. Check for +24 VDC between wire 624 (5) and ground at relay K5 (6).	<ul style="list-style-type: none"> • If +24 VDC is present, repair wiring 624 between connector N and relay K5. • If +24 VDC is not present, go to step 7.

Table 3-5. Troubleshooting (Cont)

Malfunction	Test or Inspection	Corrective Action
-------------	--------------------	-------------------

ELECTRICAL SYSTEM (CONT)

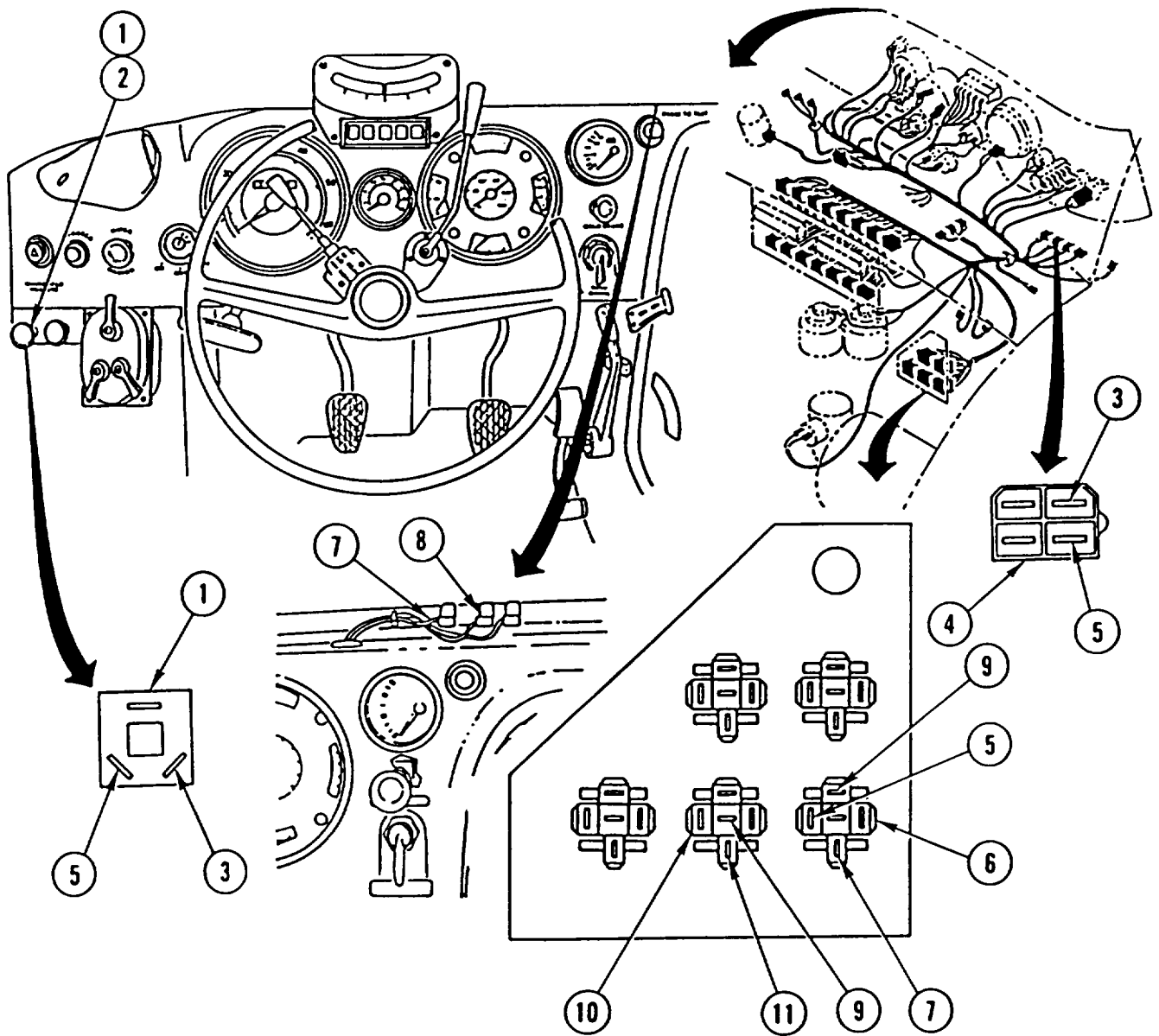

Table 3-5. Troubleshooting (Cont)

Malfunction	Test or Inspection	Corrective Action
ELECTRICAL SYSTEM (CONT)		
	Step 7. Check for +24 VDC between wire 622 (7) and ground at relay K5 (6).	<ul style="list-style-type: none"> • If +24 VDC is not present, go to step 9. • If +24 VDC is present, go to step 8.
	Step 8. Check for +24 VDC between wire 622 (7) and ground at windshield heater (8).	<ul style="list-style-type: none"> • If +24 VDC is present, notify direct support maintenance. • If +24 VDC is not present, repair wiring 622 between windshield heater and relay K5.
	Step 9. Check for +24 VDC between wire 626 (9) and ground at relay K5 (6).	<ul style="list-style-type: none"> • If +24 VDC is present, replace relay K5. • If +24 VDC is not present, go to step 10.
	Step 10. Check for +24 VDC between wire 626 (9) and ground at relay K4 (10).	<ul style="list-style-type: none"> • If +24 VDC is present, repair wiring 626 between relay K4 and relay K5. • If +24 VDC is not present, go to step 11.
	Step 11. Check for +24 VDC between wire 62 (11) and ground at relay K4 (10).	<ul style="list-style-type: none"> • If +24 VDC is present, replace relay K4. • If +24 VDC is not present, repair wiring 62 between relay K4 and fuse box 2.

Table 3-5. Troubleshooting (Cont)

Malfunction	Test or Inspection	Corrective Action
-------------	--------------------	-------------------

ELECTRICAL SYSTEM (CONT)

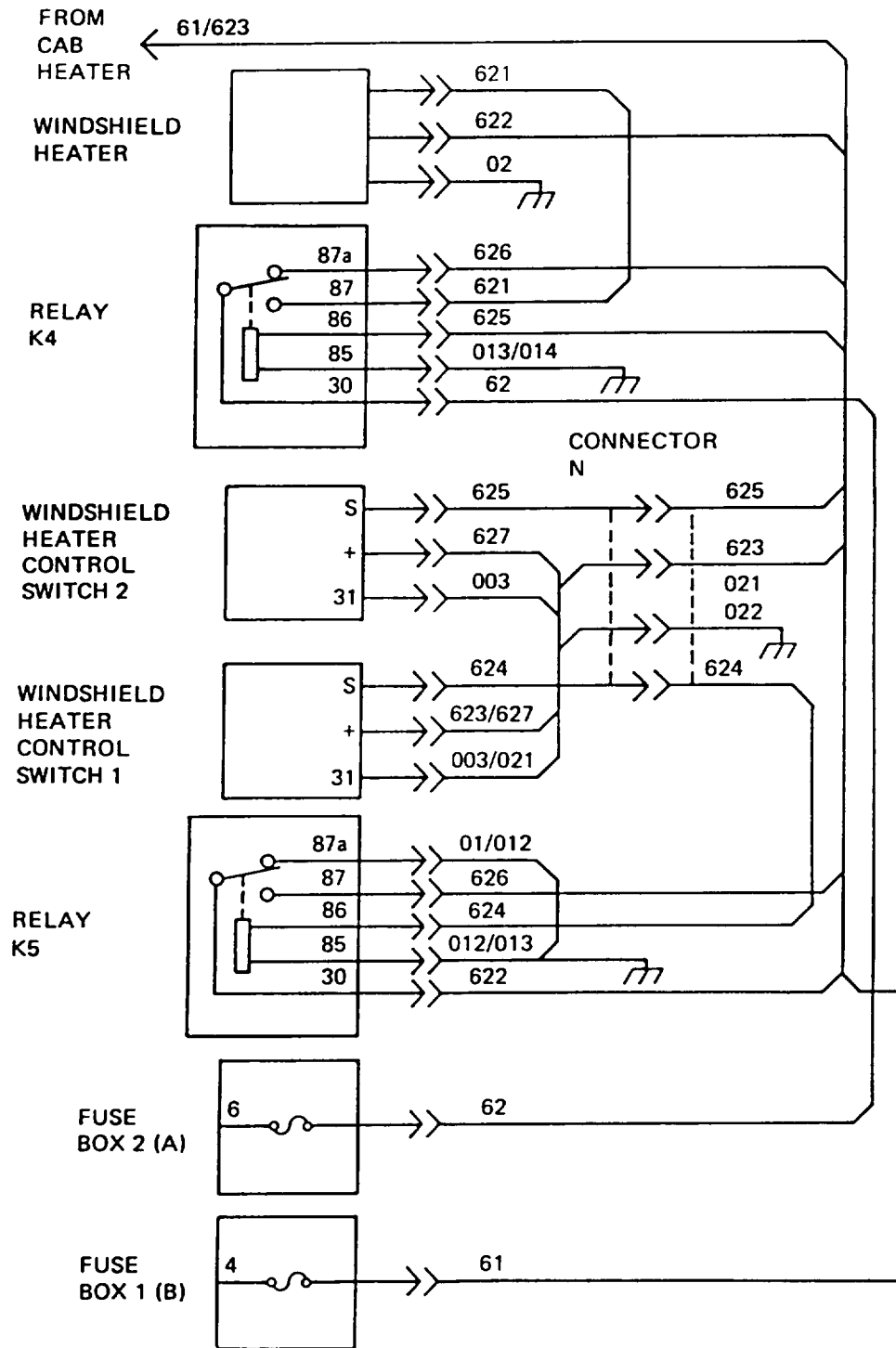

Table 3-5. Troubleshooting (Cont)

Malfunction	Test or Inspection	Corrective Action
-------------	--------------------	-------------------

ELECTRICAL SYSTEM (CONT)

49. PASSENGER SIDE WINDSHIELD HEATER WILL NOT OPERATE.

NOTE

- Make sure driver side windshield heater is turned on first. If not, passenger side windshield heater will not operate.
- Perform the following steps only after proper operation of driver side windshield heater has been verified.
- Refer to wiring diagram (page 3-162) for all wiring repair steps.

Step 1. Pull windshield heater control switch 1 (1) and then switch 2 (2) and verify lamp (3) is lit.

- If lamp is lit, go to step 3.
- If lamp is not lit, go to step 2.

Step 2. Check for +24 VDC between wire 627 (4) and ground at windshield heater control switch 2 (2).

- If +24 VDC is not present, repair wiring 627 between windshield heater control switch 1 and switch 2.
- If +24 VDC is present, replace lamp (3) and go to step 3.

Step 3. Check for +24 VDC between wire 625 (5) and ground at windshield heater control switch 2 (2).

- If +24 VDC is not present, replace windshield heater control switch 2 (page 4-139).
- If +24 VDC is present, go to step 4.

Step 4. Disconnect connector N (6) and check for +24 VDC between wire 625 (5) and ground.

- If +24 VDC is not present, repair wiring 625 between windshield heater control switch 2 and connector N.
- If +24 VDC is present, reconnect connector N and go to step 5.

Step 5. Check for +24 VDC between wire 625 (5) and ground at relay K4 (7).

- If +24 VDC is not present, repair wiring 625 between connector N and relay K4.
- If +24 VDC is present, go to step 6.

Step 6. Check for +24 VDC between wire 621 (8) and ground at relay K4 (7).

- If +24 VDC is not present, replace relay K4.
- If +24 VDC is present, go to step 7.

Table 3-5. Troubleshooting (Cont)

Malfunction	Test or Inspection	Corrective Action
-------------	--------------------	-------------------

ELECTRICAL SYSTEM (CONT)

Step 7. Check for +24 VDC between wire 621 (8) and ground at windshield heater (9).

- If +24 VDC is not present, repair wiring 621 between windshield heater and relay K4.
- If +24 VDC is present, notify direct support maintenance.

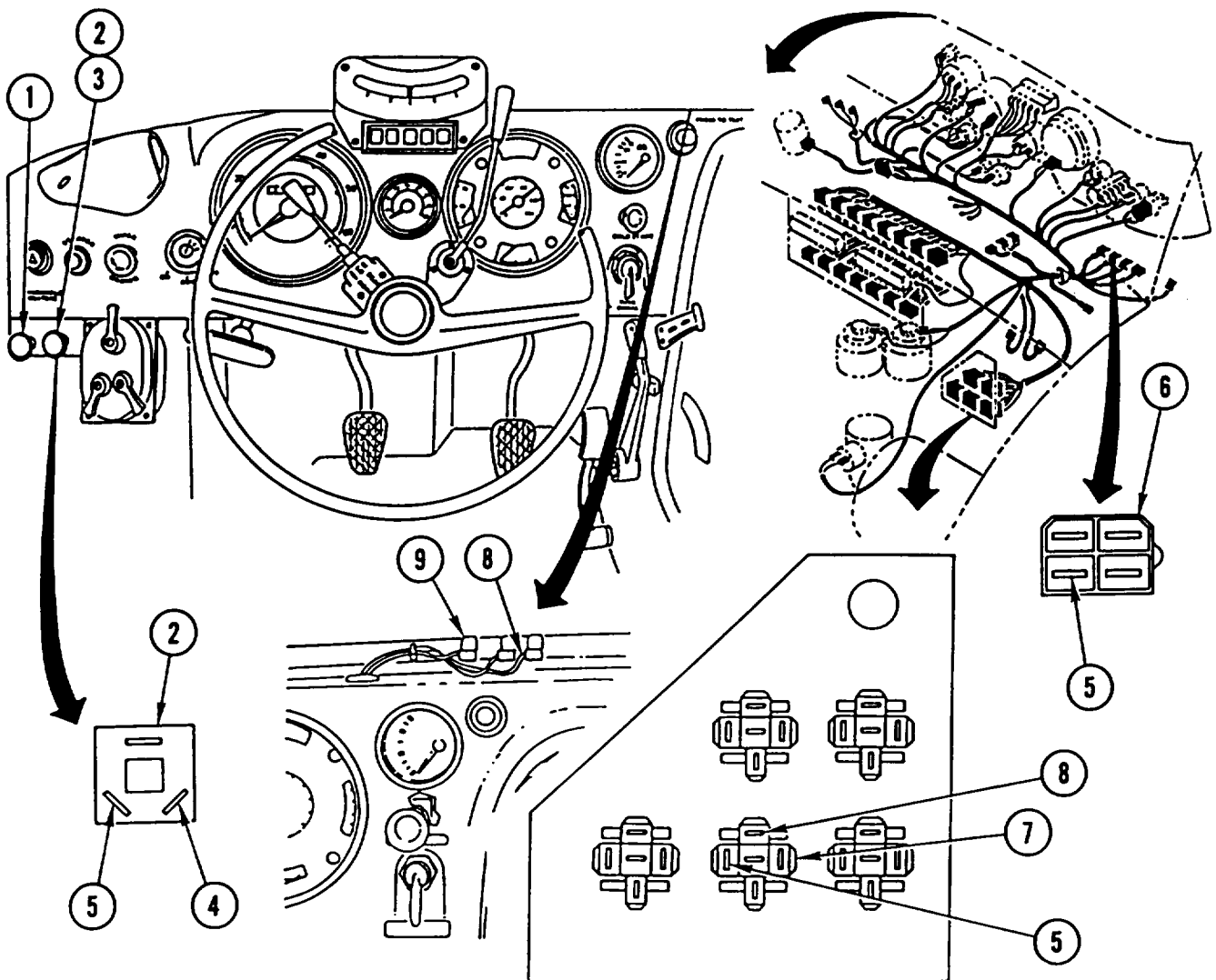

Table 3-5. Troubleshooting (Cont)

Malfunction	Test or Inspection	Corrective Action
-------------	--------------------	-------------------

ELECTRICAL SYSTEM (CONT)

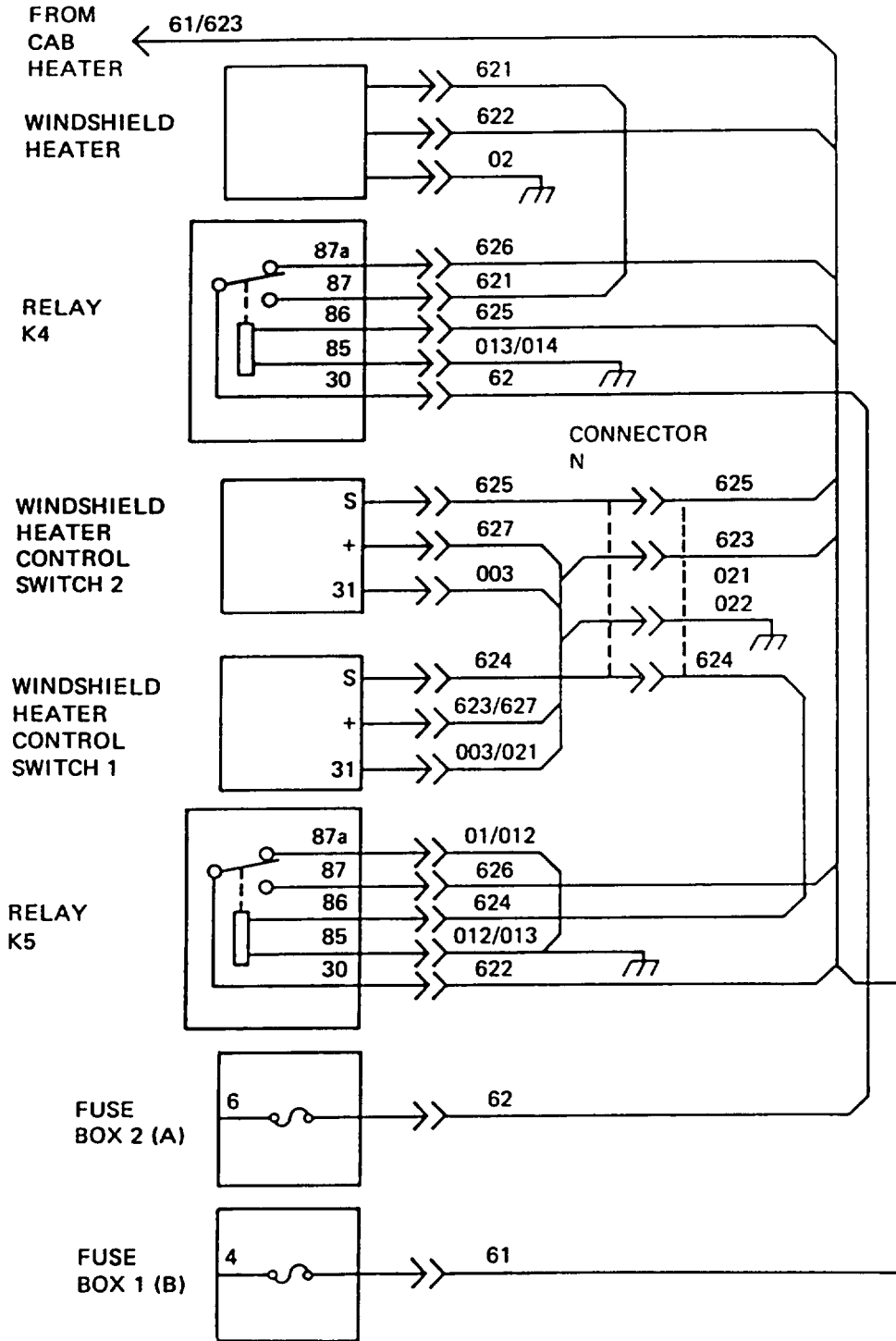

Table 3-5. Troubleshooting (Cont)

Malfunction	Test or Inspection	Corrective Action
-------------	--------------------	-------------------

ELECTRICAL SYSTEM (CONT)

50. HAZARD WARNING LIGHTS WILL NOT LIGHT.

NOTE

- Vehicle MASTER disconnect switch must be ON, ignition switch set to ON, master light switch set to SER DRIVE, and hazard warning switch depressed. Failure to do so will cause erroneous results.
- Perform the following steps only after proper operation of turn signals has been verified.
- Refer to wiring diagram (page 3-166) for all wiring repair steps.

Step 1. Remove hazard warning switch (1) and check for +24 VDC between wire 45 (2) and ground.

- If +24 VDC is not present, repair wiring 45 between hazard warning switch and fuse box 1.
- If +24 VDC is present, go to step 2.

Step 2. Check for +24 VDC between wire 451 (3) and ground at hazard warning switch (1).

- If +24 VDC is not present, repair wiring 451 between hazard warning switch terminals 15 and 30.
- If +24 VDC is present, go to step 3.

Step 3. Check for +24 VDC at wire 46 (4) and wire 452 (5) and ground at hazard warning switch (1).

- If +24 VDC is not present, replace hazard warning switch.
- If +24 VDC is present, go to step 4.

Step 4. Check for +24 VDC between wire 461 (6) and ground at turn signal flasher relay (7).

- If +24 VDC is not present, replace turn signal flasher relay (page 4-196).
- If +24 VDC is present, go to step 5.

Step 5. Check for +24 VDC between wire 461 (6) and ground at hazard warning switch (1).

- If +24 VDC is not present, repair wiring 461 between turn signal flasher relay and hazard warning switch.
- If +24 VDC is present, go to step 6.

Table 3-5. Troubleshooting (Cont)

Malfunction	Test or Inspection	Corrective Action
ELECTRICAL SYSTEM (CONT)		
Step 6.	Check for +24 VDC between wire 462 (8) and ground at turn signal lever (9).	<ul style="list-style-type: none"> • If +24 VDC is not present, repair wiring 462 between hazard warning switch and turn signal lever. • If +24 VDC is present, go to step 7.
Step 7.	Check for +24 VDC between wire 463 (10) and ground at hazard warning switch (1).	<ul style="list-style-type: none"> • If +24 VDC is not present, replace hazard warning switch. • If +24 VDC is present, go to step 8.
Step 8.	Check for +24 VDC between wire 463 (10) and ground at relay K3 (11).	<ul style="list-style-type: none"> • If +24 VDC is not present, repair wiring 463 between hazard warning switch and relay K3. • If +24 VDC is present, go to step 9.
Step 9.	Check for +24 VDC between wire 464 (12) and ground at relay K3 (11).	<ul style="list-style-type: none"> • If +24 VDC is not present, repair wiring 464 between turn signal lever and relay K3. • If +24 VDC is present, go to step 10.
Step 10.	Check for +24 VDC between wire 445 (13) and ground at relay K3 (11).	<ul style="list-style-type: none"> • If +24 VDC is not present, replace relay K3. • If +24 VDC is present, go to step 11.
Step 11.	Check for +24 VDC between wire 445 (13) and ground at brake light diode (14).	<ul style="list-style-type: none"> • If +24 VDC is not present, repair wiring 445 between relay K3 and brake light diode. • If +24 VDC is present, go to step 12.
Step 12.	Check for +24 VDC between wire 443 (15) and ground at brake light diode (14).	<ul style="list-style-type: none"> • If +24 VDC is not present, replace brake light diode (page 4-168). • If +24 VDC is present, go to step 13.
Step 13.	Check for +24 VDC between wire 443 (15) and ground at connector K (16).	<ul style="list-style-type: none"> • If +24 VDC is not present, repair wiring 443 between brake light diode and connector K. • If +24 VDC is present, go to step 14.

Table 3-5. Troubleshooting (Cont)

Malfunction	Test or Inspection	Corrective Action
-------------	--------------------	-------------------

ELECTRICAL SYSTEM (CONT)

Step 14. Check for +24 VDC between wire 444 (17) and ground at turn signal lever (9).

- If +24 VDC is present, replace turn signal lever (page 4-122).
- If +24 VDC is not present, repair wiring 444 between connector K and turn signal lever.

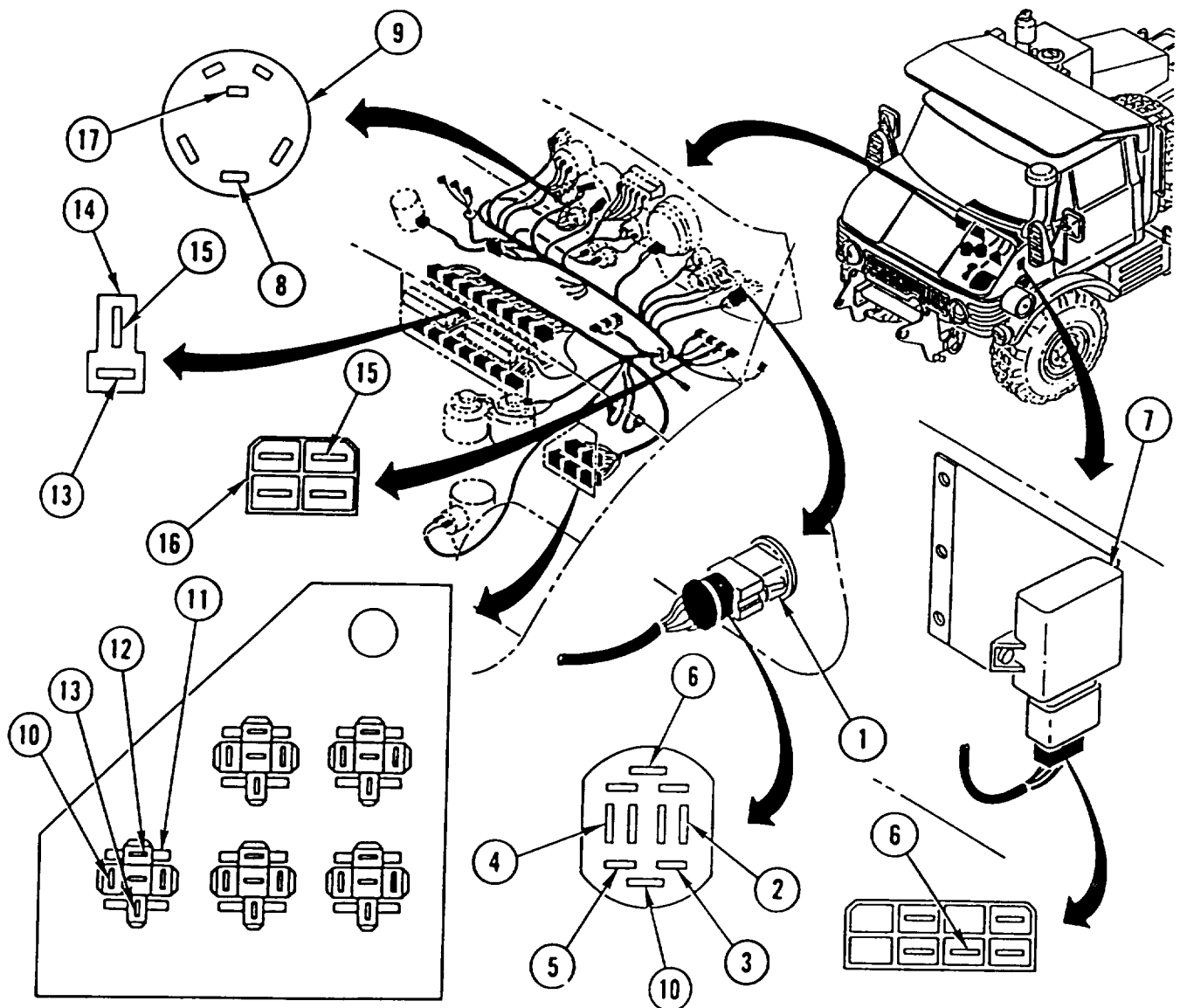
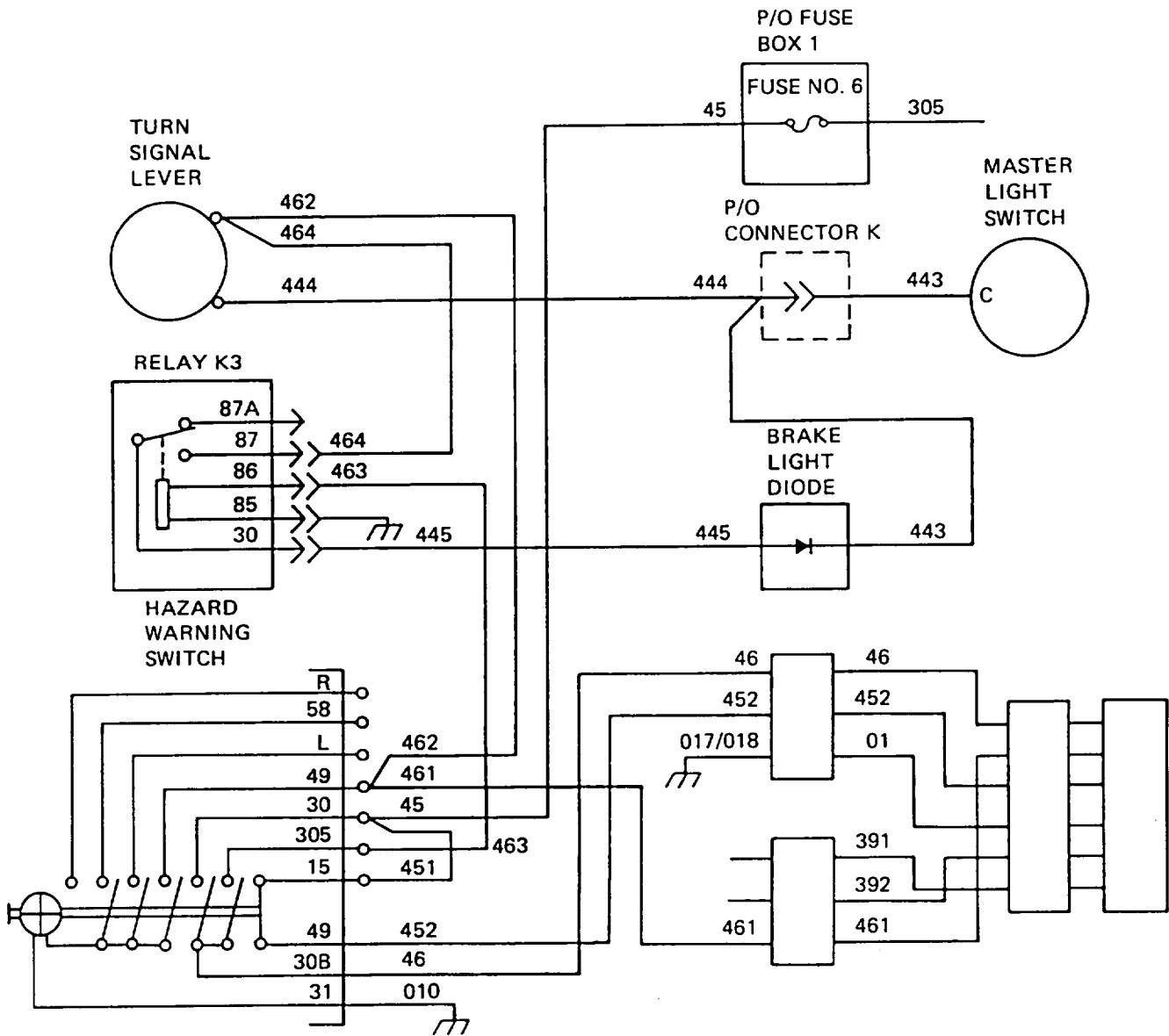

Table 3-5. Troubleshooting (Cont)

Malfunction	Test or Inspection	Corrective Action
-------------	--------------------	-------------------

ELECTRICAL SYSTEM (CONT)



51. ALL INSTRUMENT CLUSTER PANEL LIGHT INDICATORS WILL NOT LIGHT.

NOTE

- Vehicle MASTER disconnect switch must be ON and master light switch set to PANEL BRT. Failure to do so will cause erroneous results.
- Refer to wiring diagram for all wiring repair steps.

Table 3-5. Troubleshooting (Cont)

Malfunction	Test or Inspection	Corrective Action
-------------	--------------------	-------------------

ELECTRICAL SYSTEM (CONT)

Pull instrument cluster panel light (1) out of dashboard (2) and check for +24 VDC between wire 372 (3) and ground.

- If +24 VDC is present, replace instrument cluster panel light.
- If +24 VDC is not present, repair wiring 372 between instrument cluster panel light and fuse box 1.

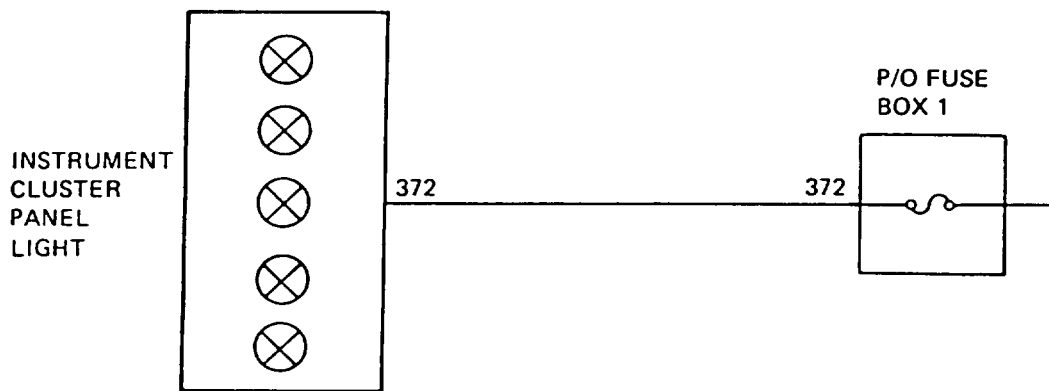
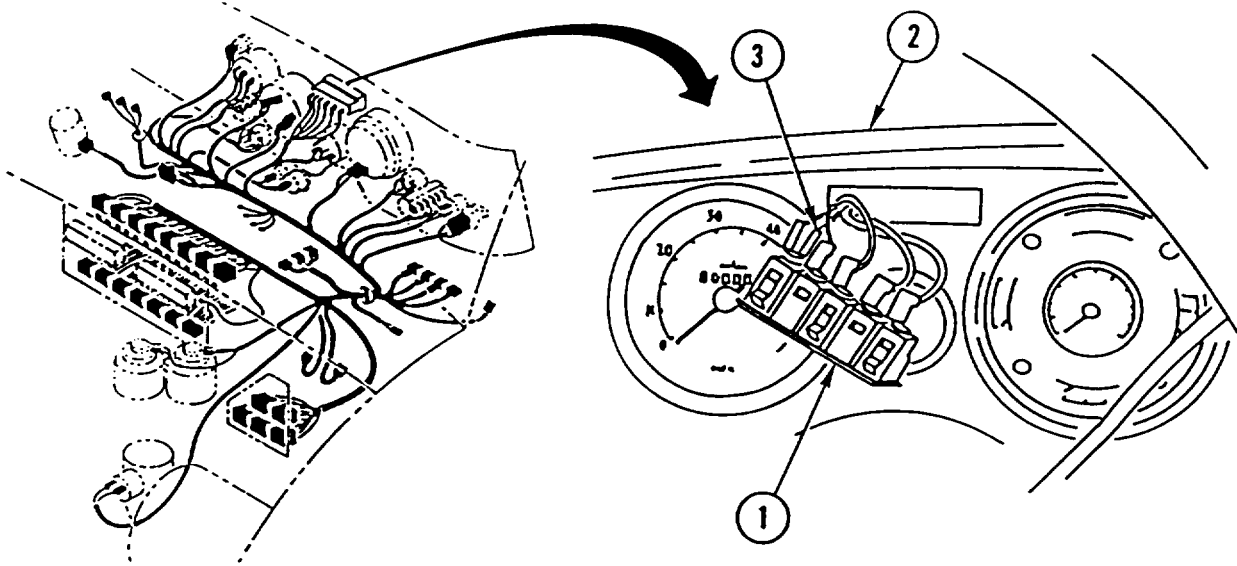

Table 3-5. Troubleshooting (Cont)

Malfunction	Test or Inspection	Corrective Action
-------------	--------------------	-------------------

ELECTRICAL SYSTEM (CONT)

52. PTO INDICATOR LIGHT WILL NOT LIGHT.

NOTE

Refer to wiring diagram for all wiring repair steps.

Step 1. Pull instrument cluster panel light (1) out of dashboard (2).

Step 2. Remove PTO indicator lamp (3) and check for continuity.

- If there is no continuity, replace lamp.
- If there is continuity, go to step 3.

NOTE

- Vehicle MASTER disconnect switch must be ON and master light switch set to PANEL BRT. Failure to do so will cause erroneous results.
- Perform steps 3 thru 5 with PTO lever engaged.

Step 3. Check for +24 VDC between wire 372 (4) and ground at instrument cluster panel light (1).

- If +24 VDC is not present, repair wiring 372 between instrument cluster panel light and fuse box 1.
- If +24 VDC is present, go to step 4.

Step 4. Disconnect connector A (5) and check for +24 VDC between wire 22 (6) and ground.

- If +24 VDC is not present, repair wiring 22 between connector A and instrument cluster panel light.
- If +24 VDC is present, reconnect connector A and go to step 5.

Step 5. Set master light switch to OFF and connect jumper between wire 22 (6) and wire 04 (7) at PTO indicator switch (8). Set master light switch to PANEL BRT and check if PTO indicator light is lit.

- If PTO indicator light is lit, replace PTO indicator switch (page 4-206).
- If PTO indicator light is not lit, repair wiring 22 between PTO indicator switch and connector A.

Table 3-5. Troubleshooting (Cont)

Malfunction	Test or Inspection	Corrective Action
-------------	--------------------	-------------------

ELECTRICAL SYSTEM (CONT)

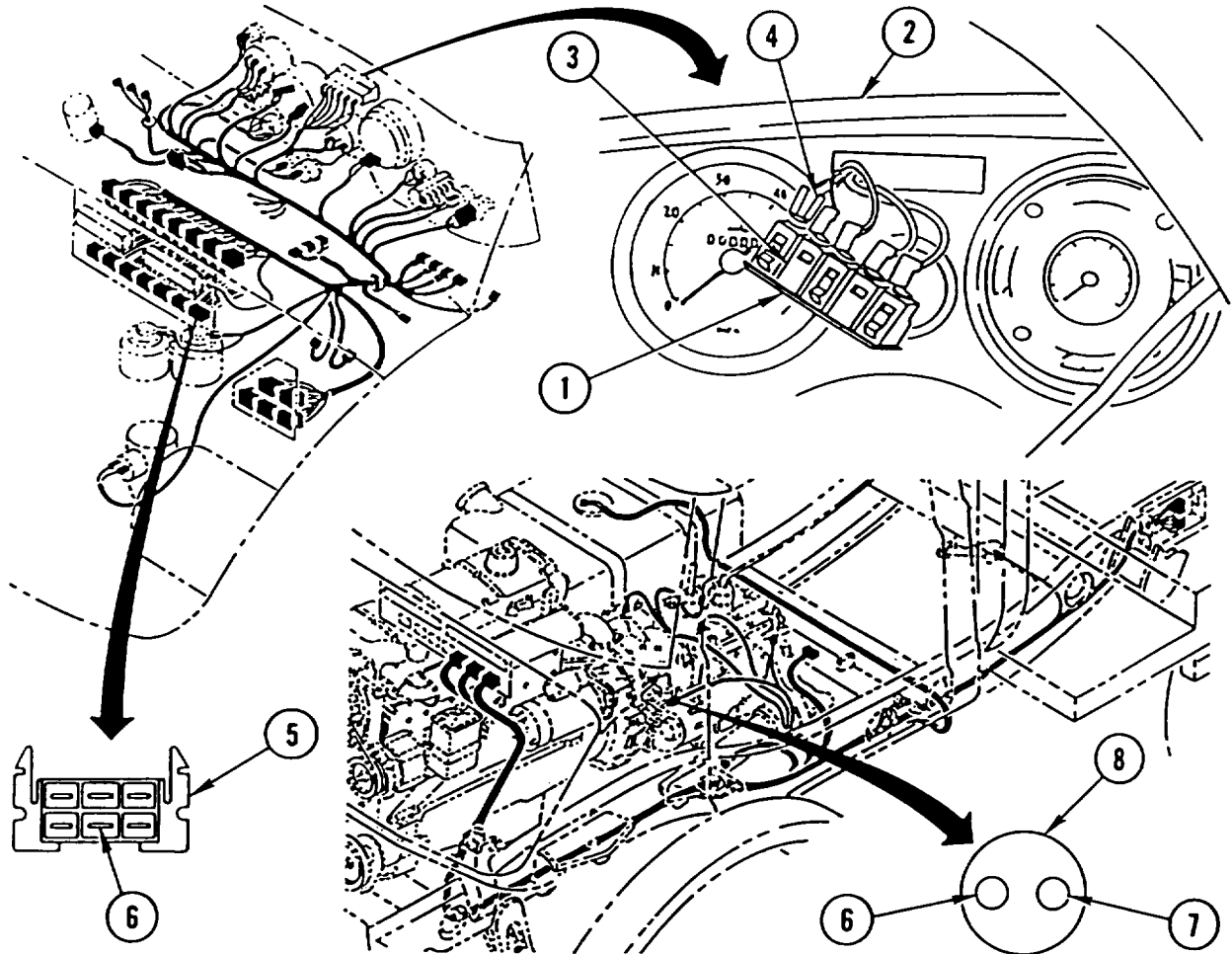

INSTRUMENT CLUSTER
PANEL LIGHT

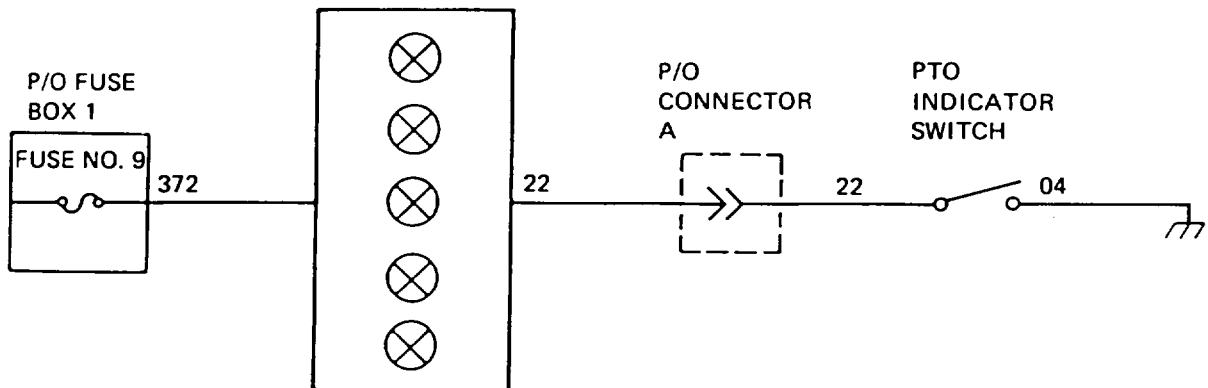

Table 3-5. Troubleshooting (Cont)

Malfunction	Test or Inspection	Corrective Action
-------------	--------------------	-------------------

ELECTRICAL SYSTEM (CONT)

53. DIFFERENTIAL LOCK INDICATOR LIGHT WILL NOT LIGHT.

NOTE

Refer to wiring diagram for all wiring repair steps.

Step 1. Pull instrument cluster panel light (1) out of dashboard (2).

Step 2. Remove differential lock indicator lamp (3) and check for continuity.

- If there is no continuity, replace lamp.
- If there is continuity, go to step 3.

NOTE

- Vehicle MASTER disconnect switch must be ON and master light switch set to PANEL BRT. Failure to do so will cause erroneous results.
- Perform steps 3 thru 5 with differential lock engaged.

Step 3. Check for +24 VDC between wire 372 (4) and ground at instrument cluster panel light (1).

- If +24 VDC is not present, repair wiring 372 between instrument cluster panel light and fuse box 1.
- If +24 VDC is present, go to step 4.

Step 4. Disconnect connector C (5) and check for +24 VDC between wire 221 (6) and ground.

- If +24 VDC is not present, repair wiring 221 between connector C and instrument cluster panel light.
- If +24 VDC is present, reconnect connector C and go to step 5.

Step 5. Set master light switch to OFF and connect jumper between wire 221 (6) and wire 03 (7) at differential lock indicator switch (8). Set master light switch to PANEL BRT and check if differential lock indicator light is lit.

- If differential lock indicator light is lit, replace differential lock indicator switch (page 4-207).
- If differential lock indicator light is not lit, repair wiring 221 between differential lock indicator switch and connector C.

Table 3-5. Troubleshooting (Cont)

Malfunction	Test or Inspection	Corrective Action
-------------	--------------------	-------------------

ELECTRICAL SYSTEM (CONT)

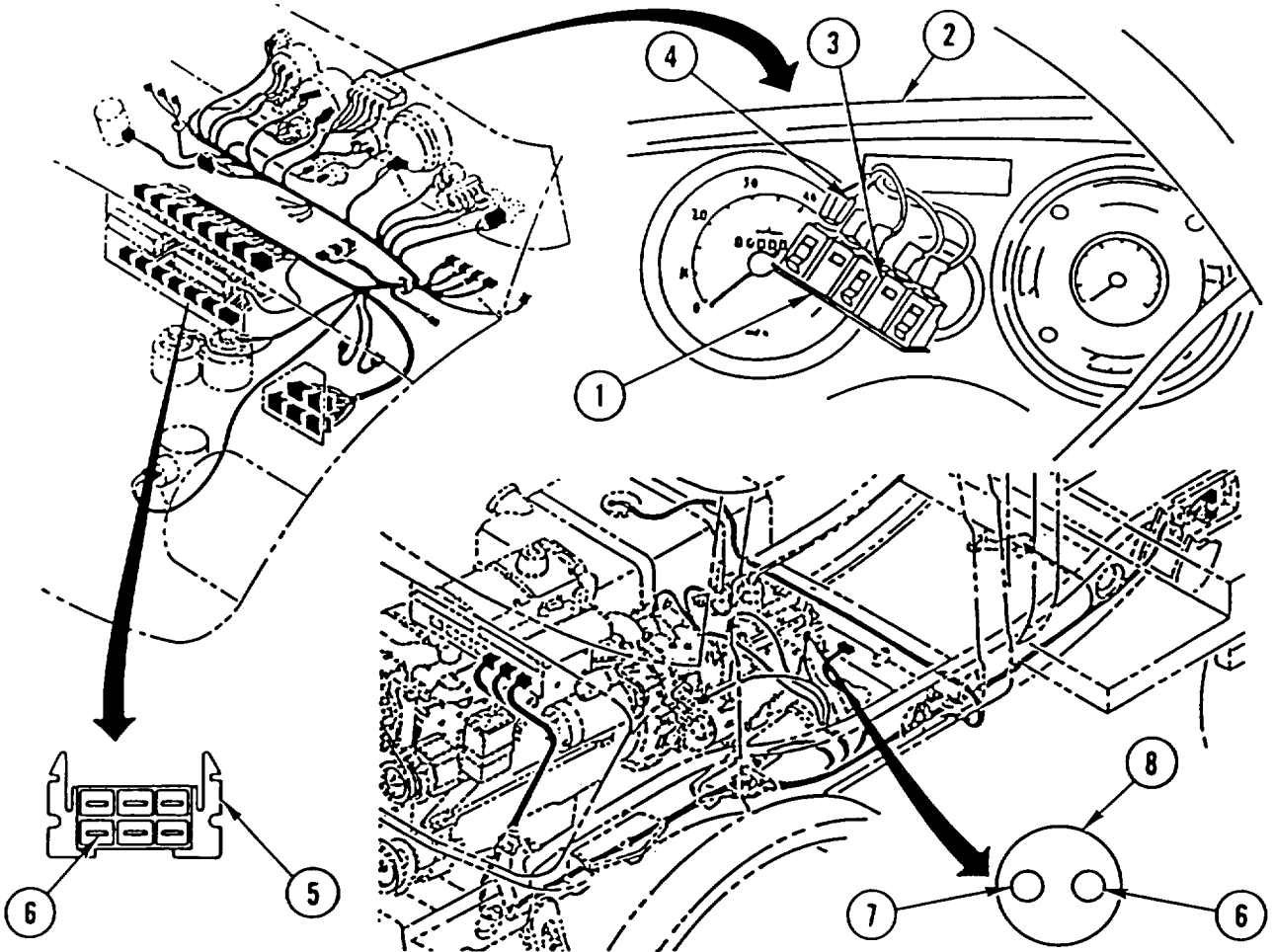

INSTRUMENT CLUSTER
PANEL LIGHT

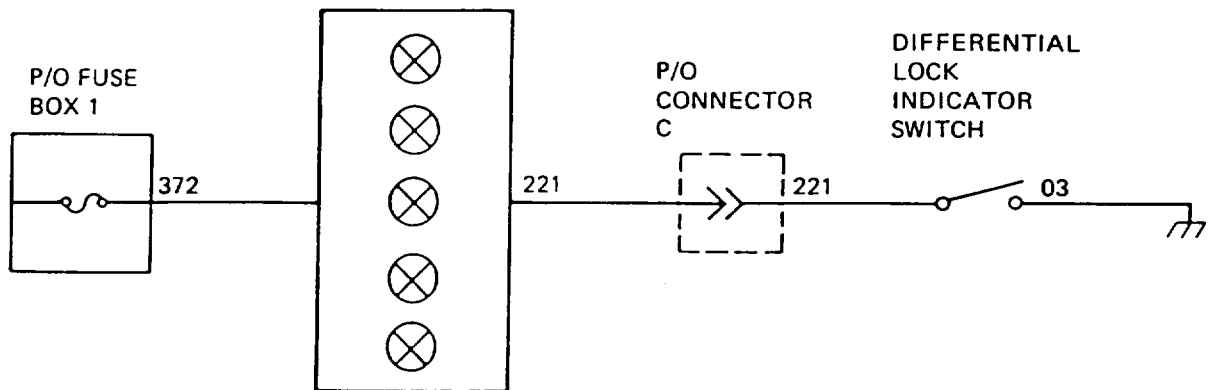

Table 3-5. Troubleshooting (Cont)

Malfunction	Test or Inspection	Corrective Action
-------------	--------------------	-------------------

ELECTRICAL SYSTEM (CONT)

54. BRAKE INDICATOR LIGHT WILL NOT LIGHT WITH PARKING BRAKE APPLIED.

NOTE

Refer to wiring diagram (page 3-174) for all wiring repair steps.

Step 1. Pull instrument cluster panel light (1) out of dashboard (2).

Step 2. Remove brake indicator lamp (3) and check for continuity.

- If there is no continuity, replace lamp.
- If there is continuity, go to step 3.

NOTE

- Vehicle MASTER disconnect switch must be ON and master light switch set to PANEL BRT. Failure to do so will cause erroneous results.

- Perform steps 3 thru 6 with parking brake applied.

Step 3. Check for +24 VDC between wire 372 (4) and ground at instrument cluster panel light (1).

- If +24 VDC is not present, repair wiring 372 between instrument cluster panel light and fuse box 1.
- If +24 VDC is present, go to step 4.

Step 4. Disconnect connector C (5) and check for +24 VDC between wire 332 (6) and ground.

- If +24 VDC is not present, repair wiring 332 between connector C and instrument cluster panel light.
- If +24 VDC is present, reconnect connector C and go to step 5.

Step 5. Disconnect connector AF (7) and check for +24 VDC between wire 332 (6) and ground.

- If +24 VDC is not present, repair wiring 332 between connector C and connector AF.
- If +24 VDC is present, reconnect connector AF and go to step 6.

Step 6. Check for +24 VDC between wire 333 (8) and ground at parking brake switch (9).

- If +24 VDC is present, replace parking brake switch (page 4-210).
- If +24 VDC is not present, repair wiring 333 between connector AF and parking brake switch.

Table 3-5. Troubleshooting (Cont)

Malfunction	Test or Inspection	Corrective Action
-------------	--------------------	-------------------

ELECTRICAL SYSTEM (CONT)

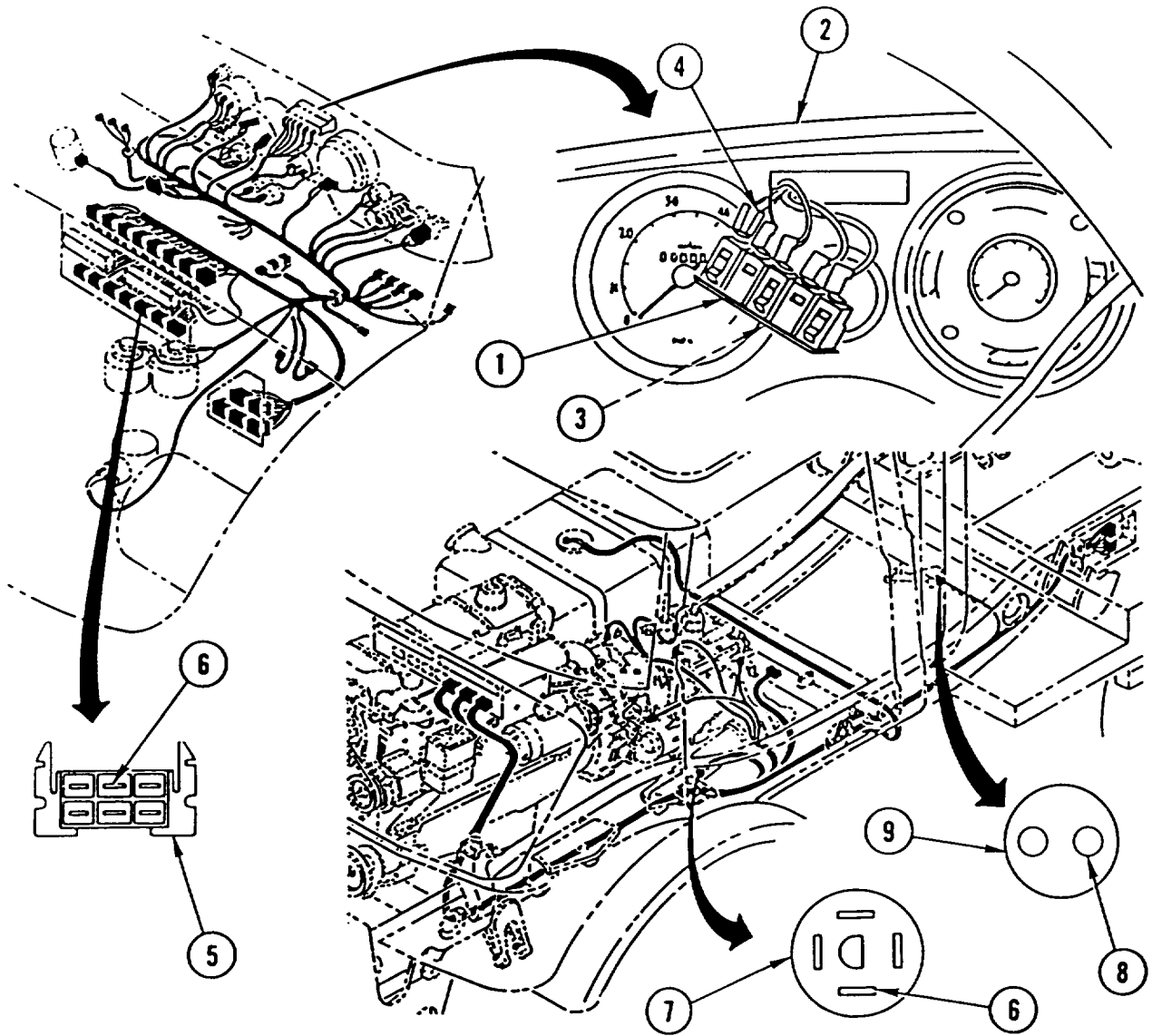

Table 3-5. Troubleshooting (Cont)

Malfunction	Test or Inspection	Corrective Action
-------------	--------------------	-------------------

ELECTRICAL SYSTEM (CONT)

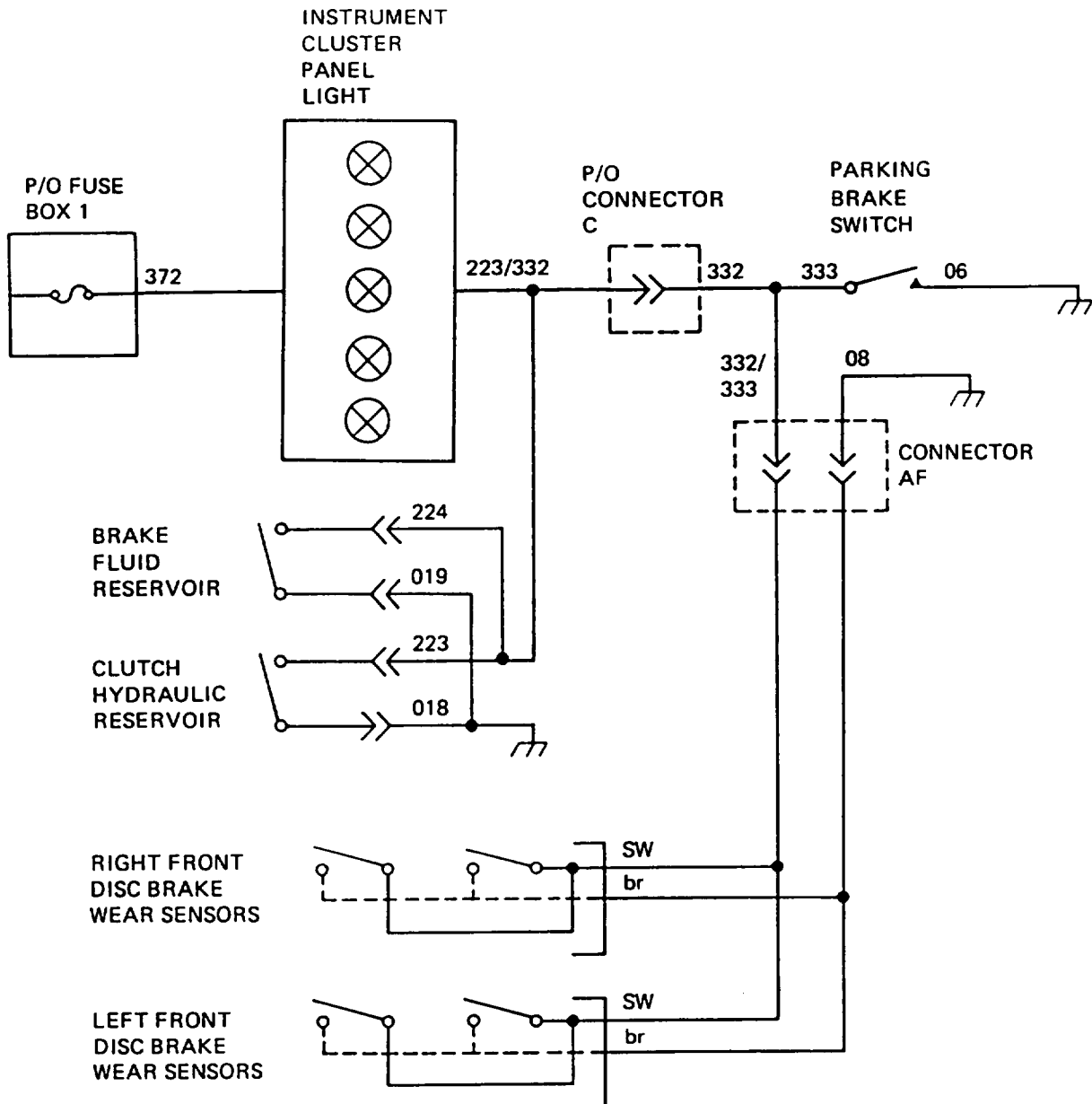

Table 3-5. Troubleshooting (Cont)

Malfunction	Test or Inspection	Corrective Action
ELECTRICAL SYSTEM (CONT)		
55. BRAKE INDICATOR LIGHT WILL NOT LIGHT WHEN BRAKE FLUID RESERVOIR OR CLUTCH HYDRAULIC RESERVOIR LOW.		<p data-bbox="818 554 899 583" style="text-align: center;">NOTE</p> <ul data-bbox="293 596 1425 705" style="list-style-type: none"> • Vehicle MASTER disconnect switch must be ON and master light switch set to PANEL BRT. Failure to do so will cause erroneous results. • Refer to wiring diagram (page 3-177) for all wiring repair steps. <p data-bbox="350 737 711 766">Step 1. Set parking brake.</p> <ul data-bbox="610 785 1403 856" style="list-style-type: none"> • if brake indicator light is not lit, perform Malfunction 54. • if brake indicator light is lit, go to step 2. <p data-bbox="818 894 899 924" style="text-align: center;">NOTE</p> <p data-bbox="558 938 1162 968" style="text-align: center;">Perform steps 2 thru 5 with parking brake off.</p> <p data-bbox="350 999 1458 1056">Step 2. Disconnect wire 223 (1) and wire 224 (2) at reservoirs (3) and check for +24 VDC.</p> <ul data-bbox="610 1079 1484 1314" style="list-style-type: none"> • If +24 VDC is present on only wire 223, repair wiring 224 between reservoirs. • If +24 VDC is not present on either wire, repair wiring 223 between brake indicator light (in instrument cluster panel light) and reservoir. • if +24 VDC is present on both wires, reconnect wire 223 and wire 224 and go to step 3. <p data-bbox="350 1346 1458 1402">Step 3. Disconnect wire 018 (4) and wire 019 (5) at reservoirs (3) and check for continuity to ground.</p> <ul data-bbox="610 1425 1458 1629" style="list-style-type: none"> • If wire 018 is short to ground but wire 019 is not, repair wiring 019 between reservoirs. • If both wires are open to ground, repair wiring 018 between reservoir and ground. • If both wires are short to ground, reconnect wire 018 and wire 019 and go to step 4. <p data-bbox="350 1661 1458 1717">Step 4. Disconnect wire 223 (1), wire 224 (2), wire 018 (4), and wire 019 (5) at reservoirs (3).</p> <p data-bbox="350 1755 1377 1812">Step 5. Remove filler opening caps (6 and 7) and check continuity between connectors (8 and 9) on each filler opening cap.</p> <ul data-bbox="610 1835 1396 1892" style="list-style-type: none"> • Replace filler opening cap that shows an open between connectors.

Table 3-5. Troubleshooting (Cont)

Malfunction	Test or Inspection	Corrective Action
-------------	--------------------	-------------------

ELECTRICAL SYSTEM (CONT)

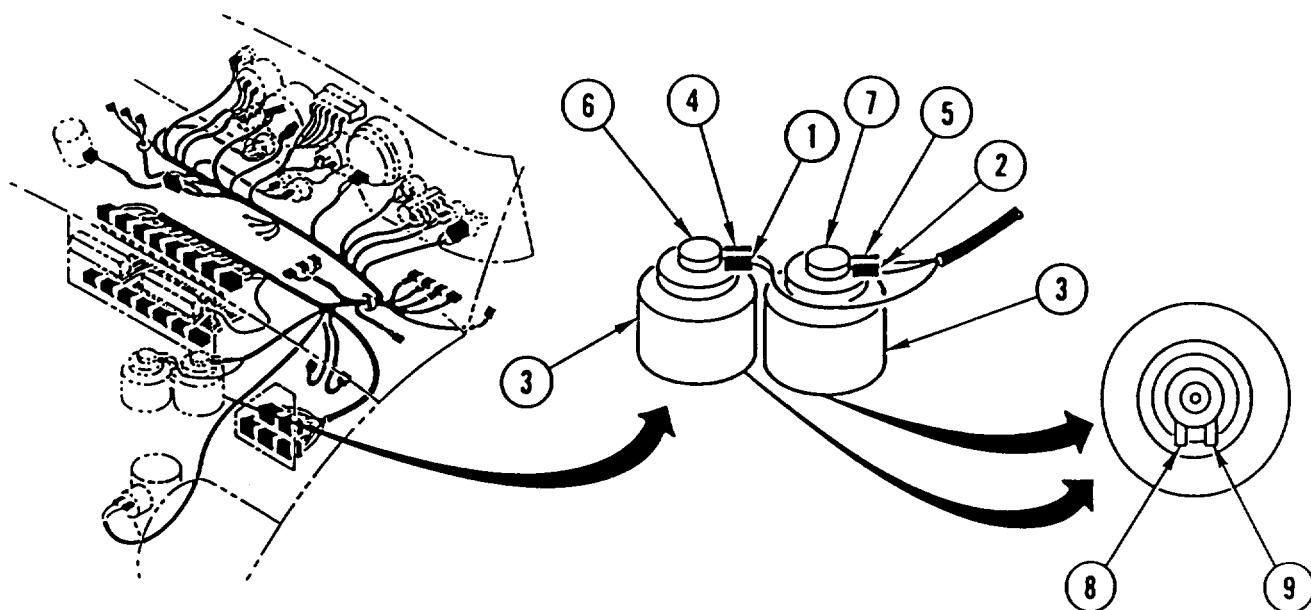

Table 3-5. Troubleshooting (Cont)

Malfunction	Test or Inspection	Corrective Action
-------------	--------------------	-------------------

ELECTRICAL SYSTEM (CONT)

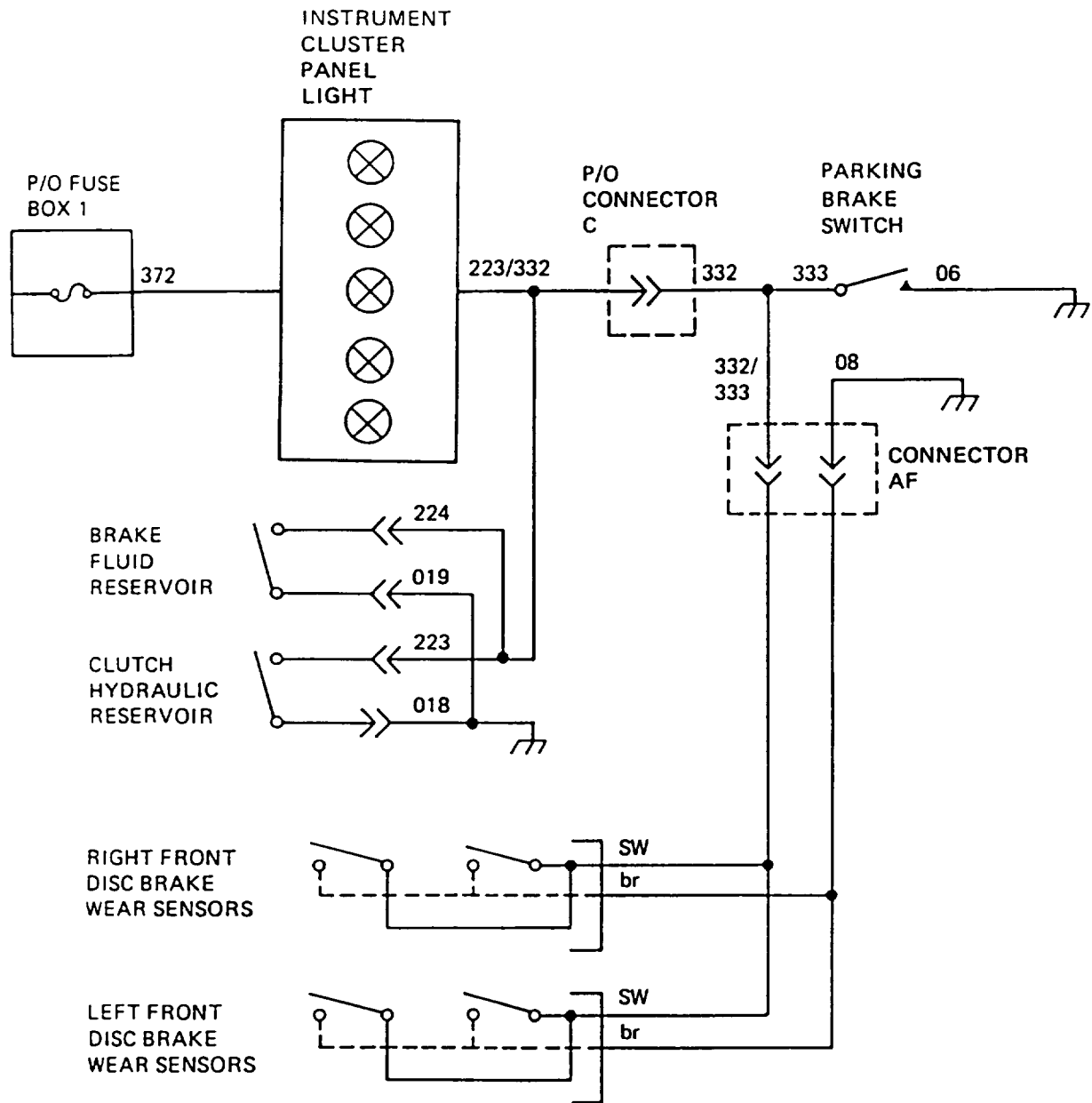

Table 3-5. Troubleshooting (Cont)

Malfunction	Test or Inspection	Corrective Action
-------------	--------------------	-------------------

ELECTRICAL SYSTEM (CONT)

56. BRAKE INDICATOR LIGHT WILL NOT LIGHT WHEN FRONT DISC BRAKE PADS WORN OUT.

NOTE

- Vehicle MASTER disconnect switch must be ON and master light switch set to PANEL BRT. Failure to do so will cause erroneous results.
- Refer to wiring diagram (page 3-180) for all wiring repair steps.

Step 1. Set parking brake.

- If brake indicator light is not lit, perform Malfunction 54.
- If brake indicator light is lit, go to step 2.

NOTE

Perform steps 2 thru 4 with parking brake off.

Step 2. Disconnect connector AF (1) and check for +24 VDC between wire 332 (2) and ground.

- If +24 VDC is not present, repair wiring 332 between connector C and connector AF.
- If +24 VDC is present, reconnect connector AF and go to step 3.

Step 3. Disconnect leads (3) from disc brake pad indicator connector (4) at both front disc brake assemblies (5).

Step 4. Check for +24 VDC between disc brake pad indicator connector (4) and ground.

- If +24 VDC is not present, replace front disc brake pad indicator wiring harness (page 4-231).
- If +24 VDC is present, replace hook switches (6).

Table 3-5. Troubleshooting (Cont)

Malfunction	Test or Inspection	Corrective Action
-------------	--------------------	-------------------

ELECTRICAL SYSTEM (CONT)

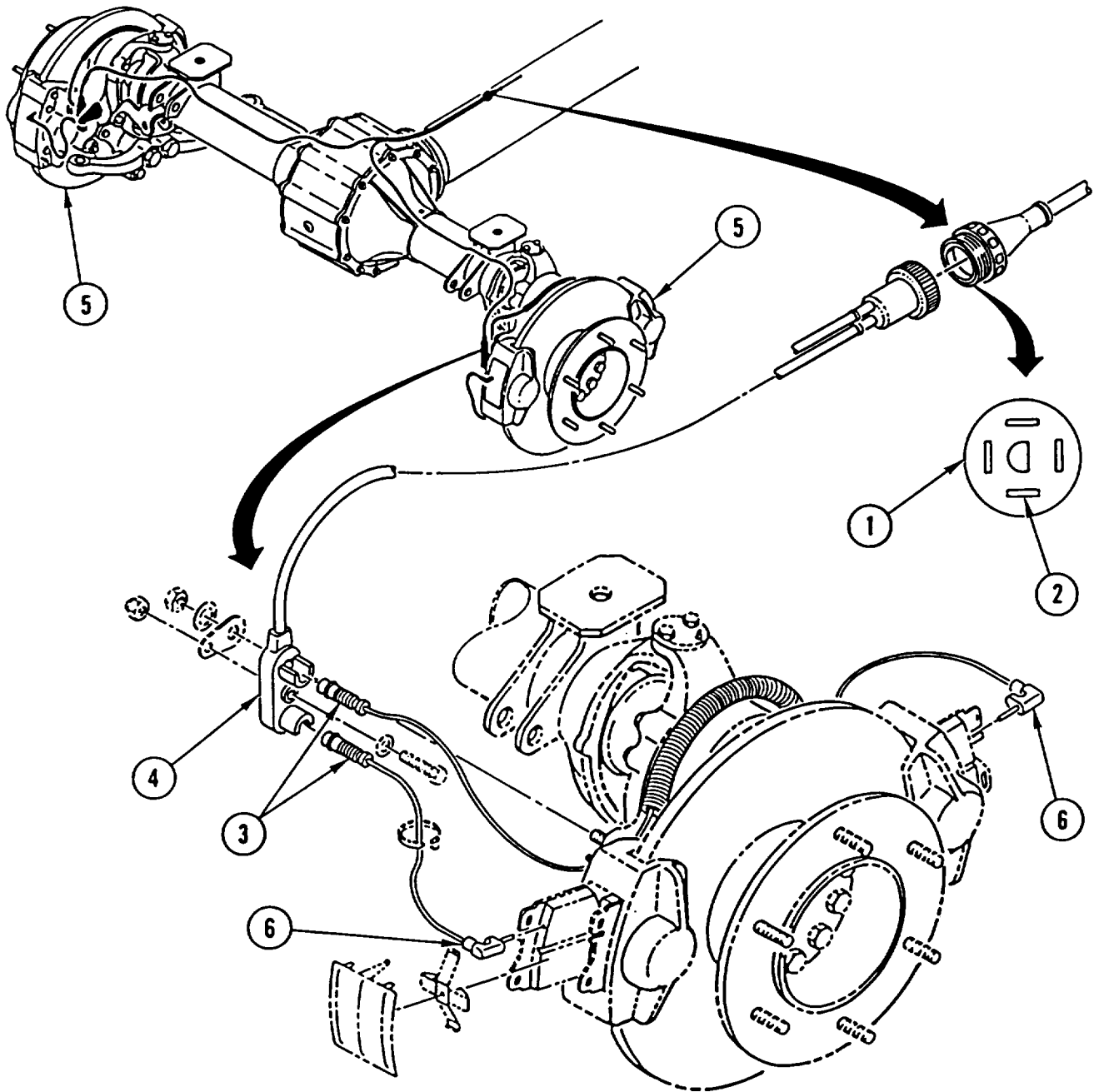

Table 3-5. Troubleshooting (Cont)

Malfunction	Test or Inspection	Corrective Action
-------------	--------------------	-------------------

ELECTRICAL SYSTEM (CONT)

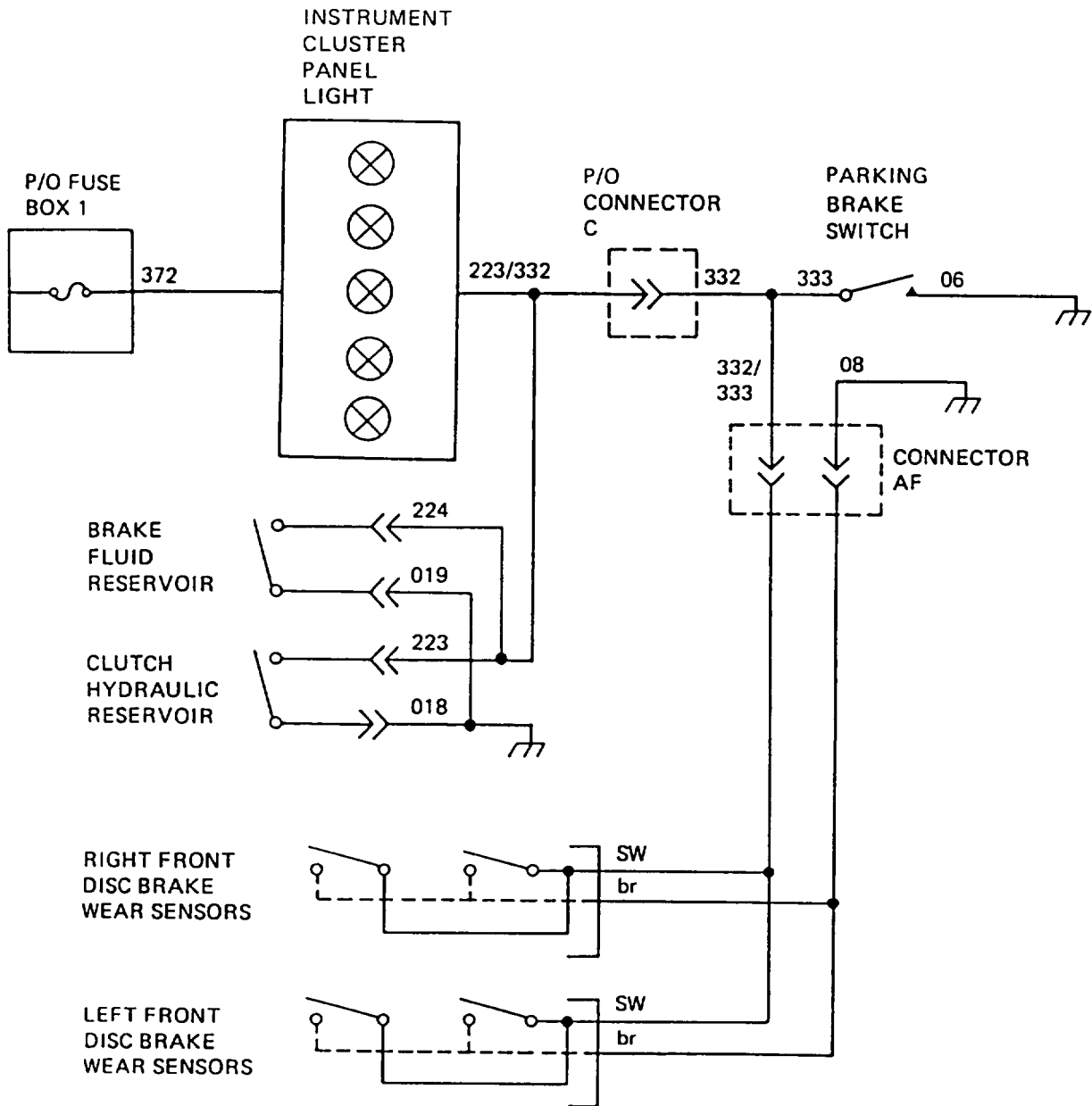

Table 3-5. Troubleshooting (Cont)

Malfunction	Test or Inspection	Corrective Action
-------------	--------------------	-------------------

ELECTRICAL SYSTEM (CONT)

57. AIR CLEANER RESTRICTOR INDICATOR LIGHT WILL NOT LIGHT.

NOTE

Refer to wiring diagram (page 3-183) for all wiring repair steps.

Step 1. Pull instrument cluster panel light (1) out of dashboard (2).

Step 2. Remove air cleaner restrictor indicator lamp (3) and check for continuity.

- If there is no continuity, replace lamp.
- If there is continuity, go to step 3.

NOTE

Vehicle MASTER disconnect switch must be ON, ignition switch set to ON, and master light switch set to PANEL BRT. Failure to do so will cause erroneous results.

Step 3. Check for +24 VDC between wire 372 (4) and ground at instrument cluster panel light (1).

- If +24 VDC is not present, repair wiring 372 between instrument cluster panel light and fuse box 1.
- If +24 VDC is present, go to step 4.

Step 4. Set master light switch to OFF and connect jumper across air cleaner restrictor indicator switch terminals (5). Set master light switch to PANEL BRT and check if air cleaner restrictor indicator light is lit.

- If air cleaner restrictor indicator light is lit, replace air cleaner restrictor indicator switch (page 4-205).
- If air cleaner restrictor indicator light is not lit, repair wiring 371 between instrument cluster panel light and air cleaner restrictor indicator switch.

Table 3-5. Troubleshooting (Cont)

Malfunction	Test or Inspection	Corrective Action
-------------	--------------------	-------------------

ELECTRICAL SYSTEM (CONT)

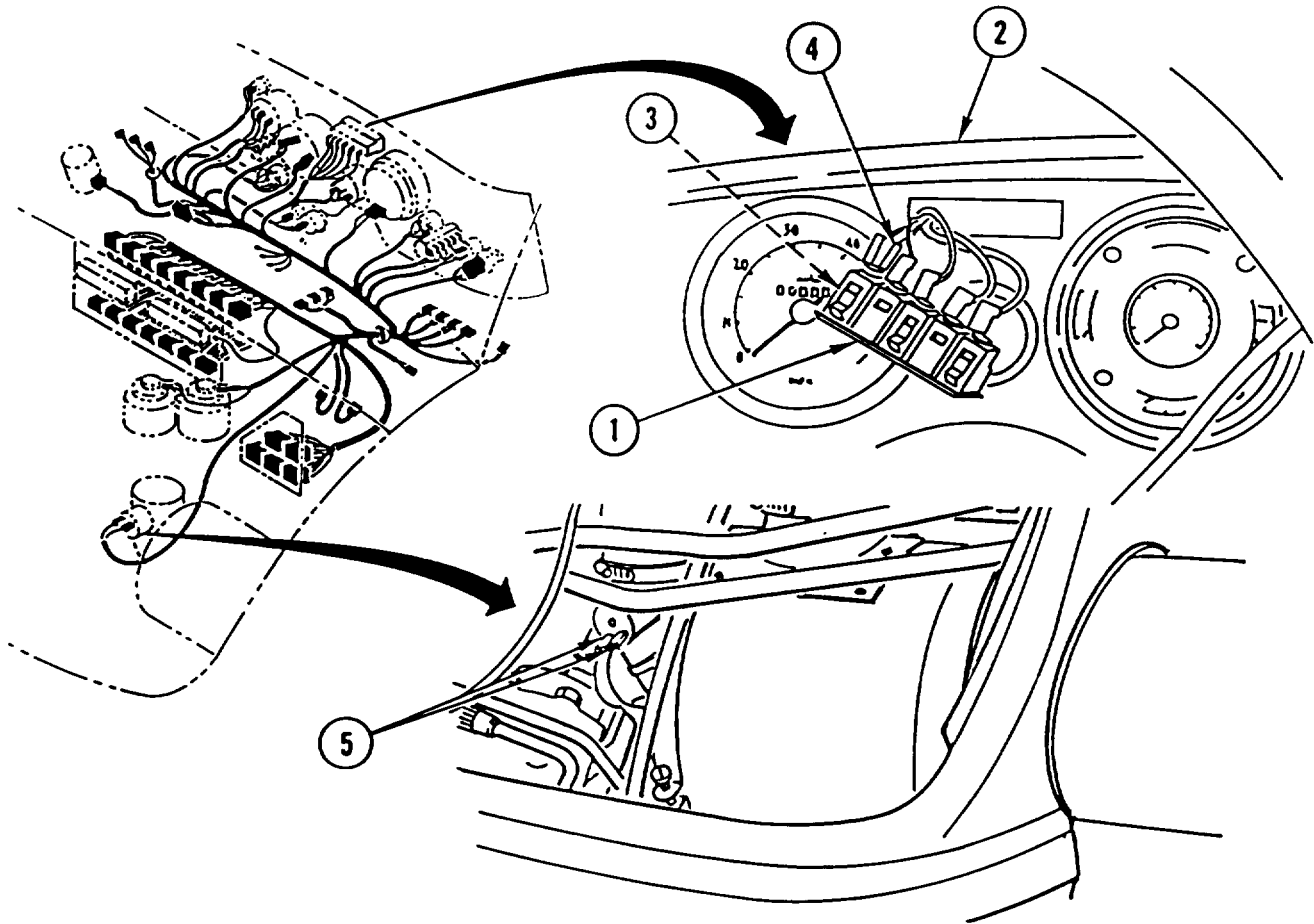

Table 3-5. Troubleshooting (Cont)

Malfunction	Test or Inspection	Corrective Action
-------------	--------------------	-------------------

ELECTRICAL SYSTEM (CONT)

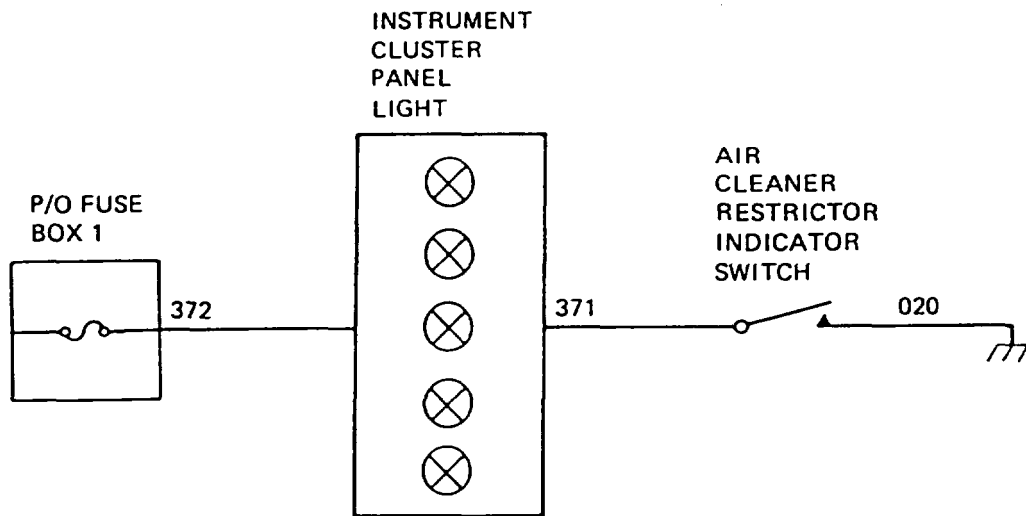

Table 3-5. Troubleshooting (Cont)

Malfunction	Test or Inspection	Corrective Action
-------------	--------------------	-------------------

ELECTRICAL SYSTEM (CONT)

58. INTERMEDIATE SPEED INDICATOR LIGHT WILL NOT LIGHT.

NOTE

Refer to wiring diagram for all wiring repair steps.

Step 1. Pull instrument cluster panel light (1) out of dashboard (2).

Step 2. Remove intermediate speed indicator lamp (3) and check for continuity.

- If there is no continuity, replace lamp.
- If there is continuity, go to step 3.

NOTE

Vehicle MASTER disconnect switch must be ON, ignition switch set to ON, and master light switch set to PANEL BRT, Failure to do so will cause erroneous results.

Step 3. Check for +24 VDC between wire 372 (4) and ground at instrument cluster panel light (1).

- If +24 VDC is not present, repair wiring 372 between instrument cluster panel light and fuse box 1.
- If +24 VDC is present, go to step 4.

Step 4. Set master light switch to OFF and connect jumper across intermediate speed shift and indicator switch terminals (5). Set master light switch to PANEL BRT and check if intermediate speed indicator light is lit.

- If intermediate speed indicator light is lit, replace intermediate speed shift and indicator switch (page 4-209).
- If intermediate speed indicator light is not lit, repair wiring 222 between instrument cluster panel light and intermediate speed shift and indicator switch.

Table 3-5. Troubleshooting (Cont)

Malfunction	Test or Inspection	Corrective Action
-------------	--------------------	-------------------

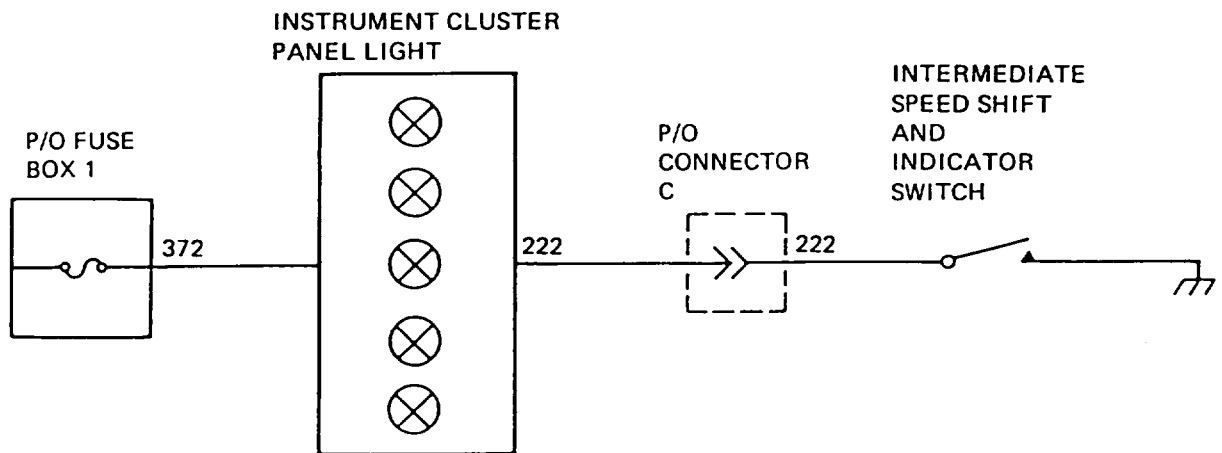
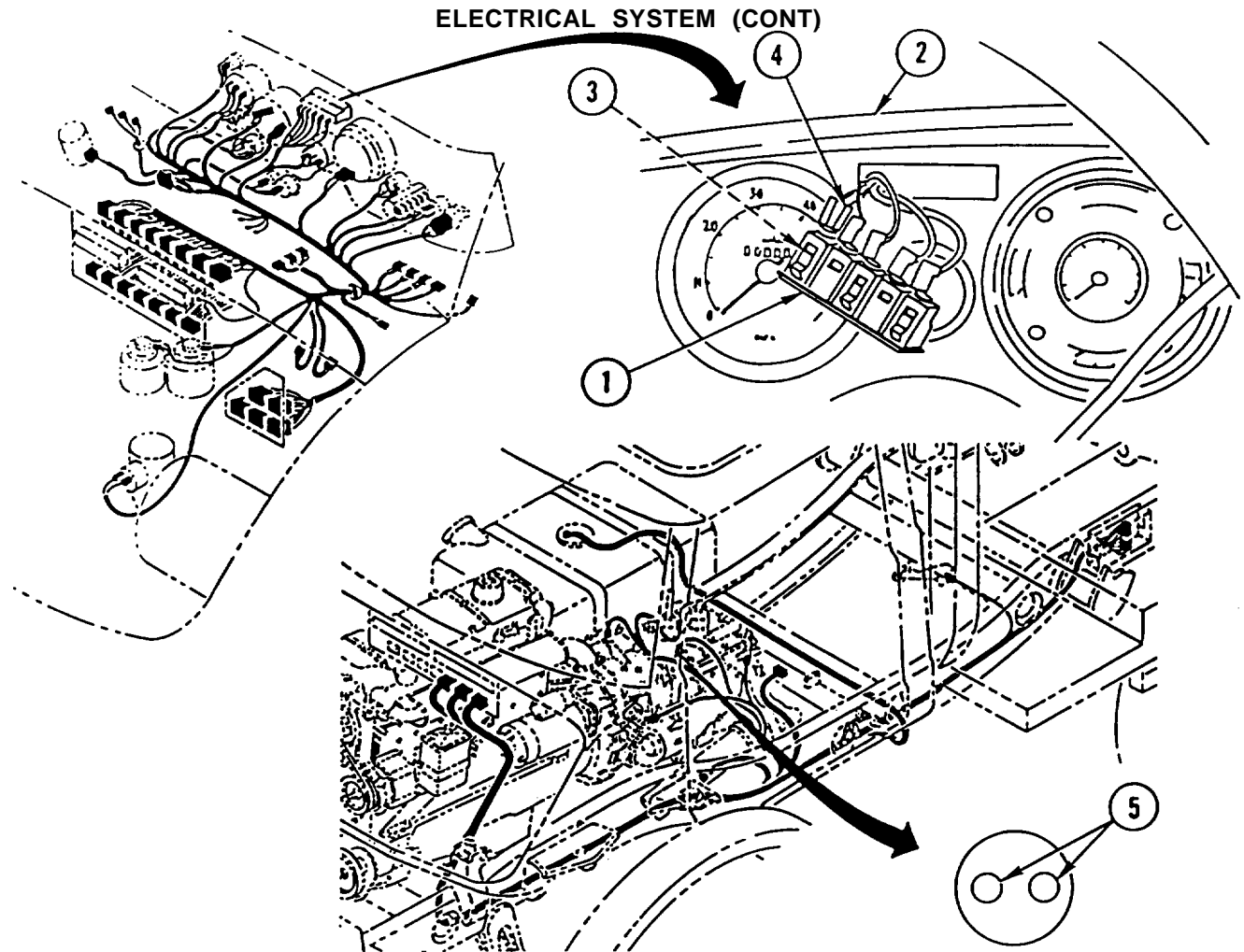

Table 3-5. Troubleshooting (Cont)

Malfunction	Test or Inspection	Corrective Action
-------------	--------------------	-------------------

ELECTRICAL SYSTEM (CONT)

59. INTERMEDIATE SPEED WILL NOT ENGAGE.

NOTE

- Vehicle MASTER disconnect switch must be ON, ignition switch set to ON, and clutch pedal fully depressed. Failure to do so will cause erroneous results.
- Refer to wiring diagram for all wiring repair steps.

Step 1. Disconnect connector C (1) and check for +24 VDC between wire 23A (2) and ground.

- If +24 VDC is not present, repair wiring 23A between connector C and connector J.
- If +24 VDC is present, reconnect connector C and go to step 2.

Step 2. Check for +24 VDC between wire 23A (2) and ground at air shift solenoid valve (3).

- If +24 VDC is not present, repair wiring 23A between connector C and air shift solenoid valve.
- If +24 VDC is present, notify direct support maintenance.

Table 3-5. Troubleshooting (Cont)

Malfunction	Test or Inspection	Corrective Action
-------------	--------------------	-------------------

ELECTRICAL SYSTEM (CONT)

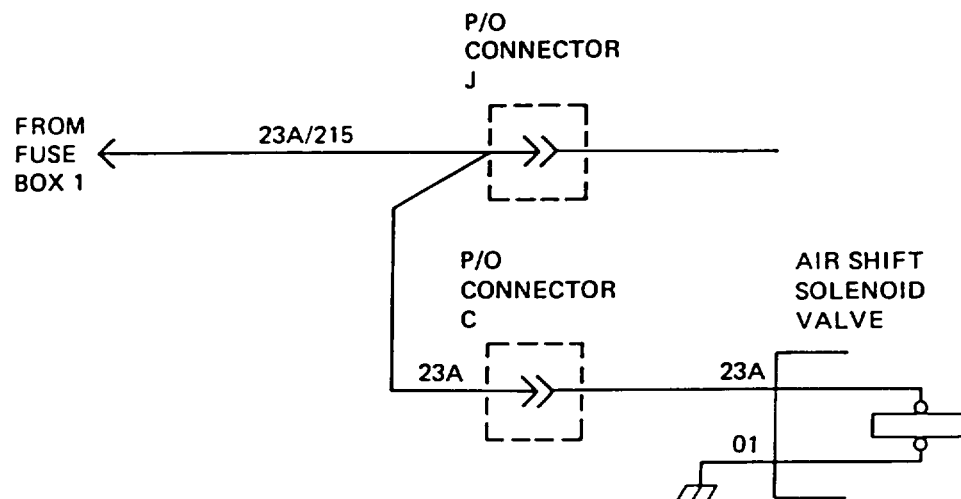
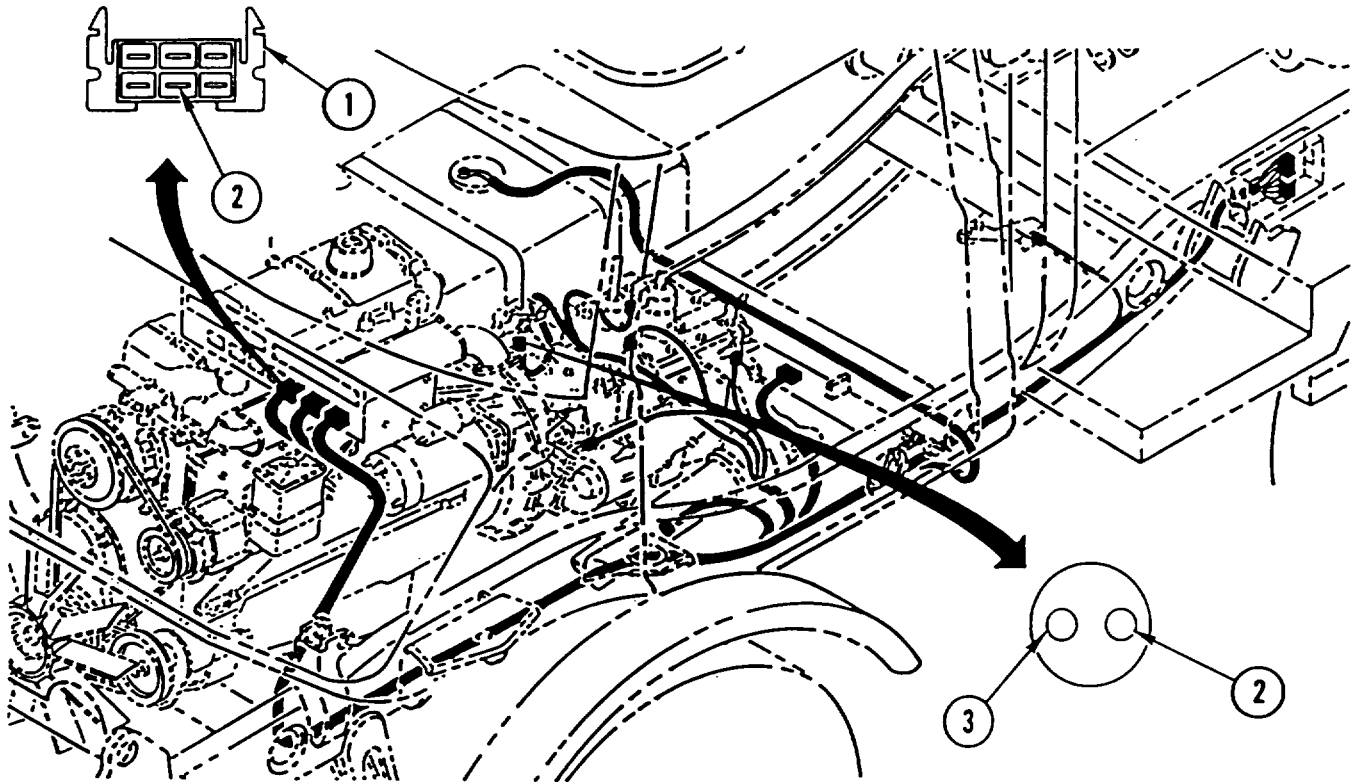

Table 3-5. Troubleshooting (Cont)

Malfunction	Test or Inspection	Corrective Action
-------------	--------------------	-------------------

ELECTRICAL SYSTEM (CONT)

60. BRAKE LIGHTS WILL NOT LIGHT WHEN BRAKE PEDAL APPLIED.

NOTE

- Master light switch must be set to SER DRIVE or STOP LIGHT, brake pedal depressed, and turn signal lever off. Failure to do so will cause erroneous results.
- Refer to wiring diagram (page 3-191) for all wiring repair steps.

Step 1. Check for +24 VDC between wire 442 (1) and ground at brake light switch (2).

- If +24 VDC is present, go to step 7.
- If +24 VDC is not present, go to step 2.

Step 2. Check for +24 VDC between wire 441 (3) and ground at brake light switch (2).

- If +24 VDC is present, replace brake light switch (page 4-200).
- If +24 VDC is not present, go to step 3.

Step 3. Disconnect connector J (4) and check for +24 VDC between wire 441 (3) and ground.

- If +24 VDC is present, repair wiring 441 between connector J and brake light switch.
- If +24 VDC is not present, reconnect connector J and go to step 4.

Step 4. Loosen two captive screws (5) and pull bracket (6) out enough to gain access to area behind bracket.

Step 5. Remove two clamps (7) and pipe assembly (8).

Step 6. Check for +24 VDC between wire 441 (3) and ground at fuse box 1 (9).

- If +24 VDC is present, repair wiring 441 between fuse box 1 and connector J.
- If +24 VDC is not present, replace fuse.

Step 7. Check for +24 VDC between wire 444 (10) and ground at turn signal lever (11).

- If +24 VDC is present, replace turn signal lever (page 4-122).
- If +24 VDC is not present, go to step 8.

Table 3-5. Troubleshooting (Cont)

Malfunction	Test or Inspection	Corrective Action
ELECTRICAL SYSTEM (CONT)		
Step 8.	Disconnect connector K (12) and check for +24 VDC between wire 444 (10) and ground.	<ul style="list-style-type: none"> • If +24 VDC is present, repair wiring 444 between connector K and turn signal lever. • If +24 VDC is not present, reconnect connector K and go to step 9.
Step 9.	Check for +24 VDC between wire 443 (13) and ground at master light switch (14).	<ul style="list-style-type: none"> • If +24 VDC is present, repair wiring 443 between master light switch and connector K. • If +24 VDC is not present, go to step 10.
Step 10.	Disconnect connector M (15) and check for +24 VDC between wire 442 (1) and ground.	<ul style="list-style-type: none"> • If +24 VDC is present, repair wiring 442 between connector M and master light switch. • If +24 VDC is not present, reconnect connector M and go to step 11.
Step 11.	Disconnect connector J (4) and check for +24 VDC between wire 442 (1) and ground.	<ul style="list-style-type: none"> • If +24 VDC is present, repair wiring 442 between connector J and connector M. • If +24 VDC is not present, repair wiring 442 between connector J and brake light switch.

Table 3-5. Troubleshooting (Cont)

Malfunction	Test or Inspection	Corrective Action
-------------	--------------------	-------------------

ELECTRICAL SYSTEM (CONT)

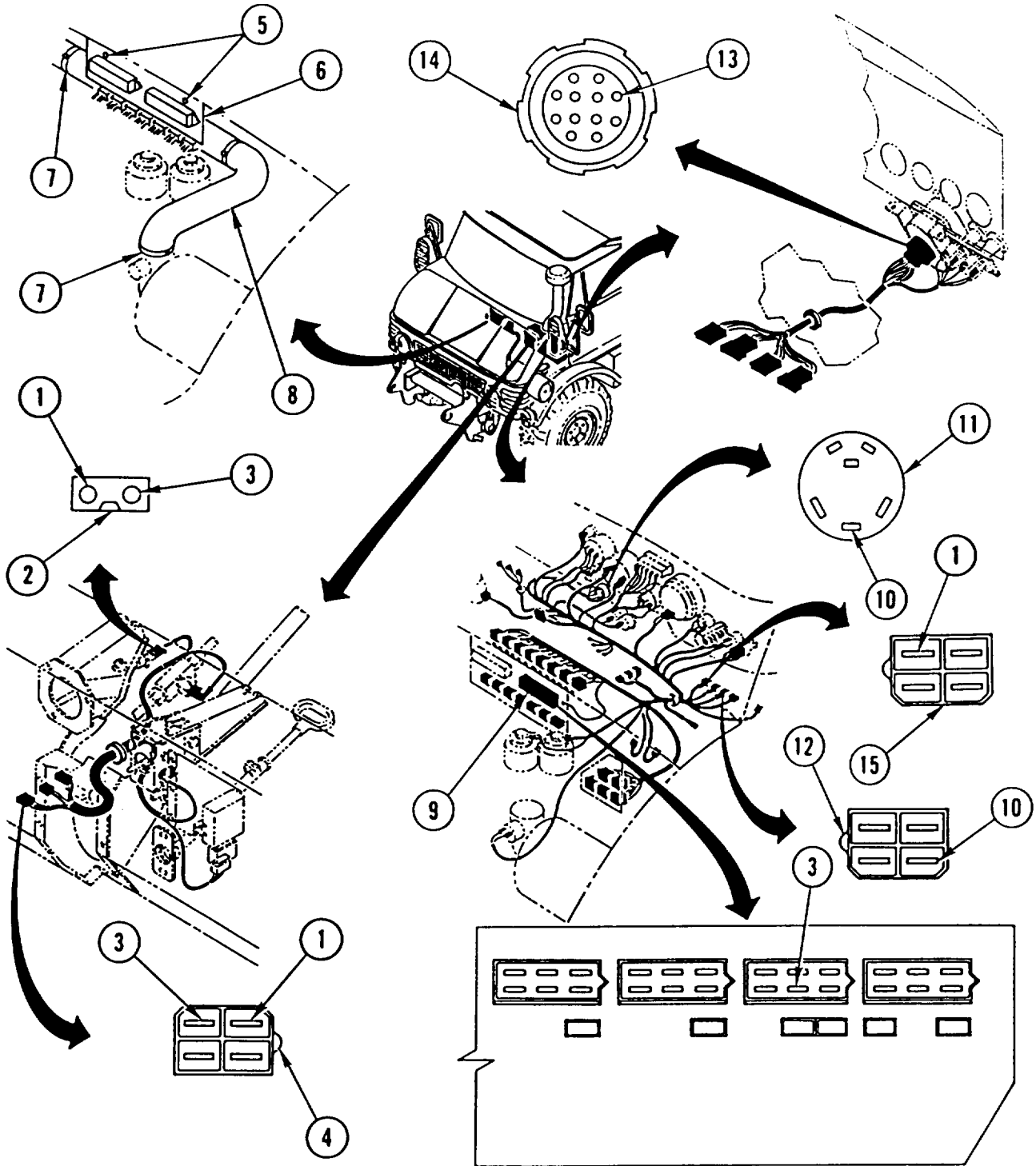

Table 3-5. Troubleshooting (Cont)

Malfunction	Test or Inspection	Corrective Action
-------------	--------------------	-------------------

ELECTRICAL SYSTEM (CONT)

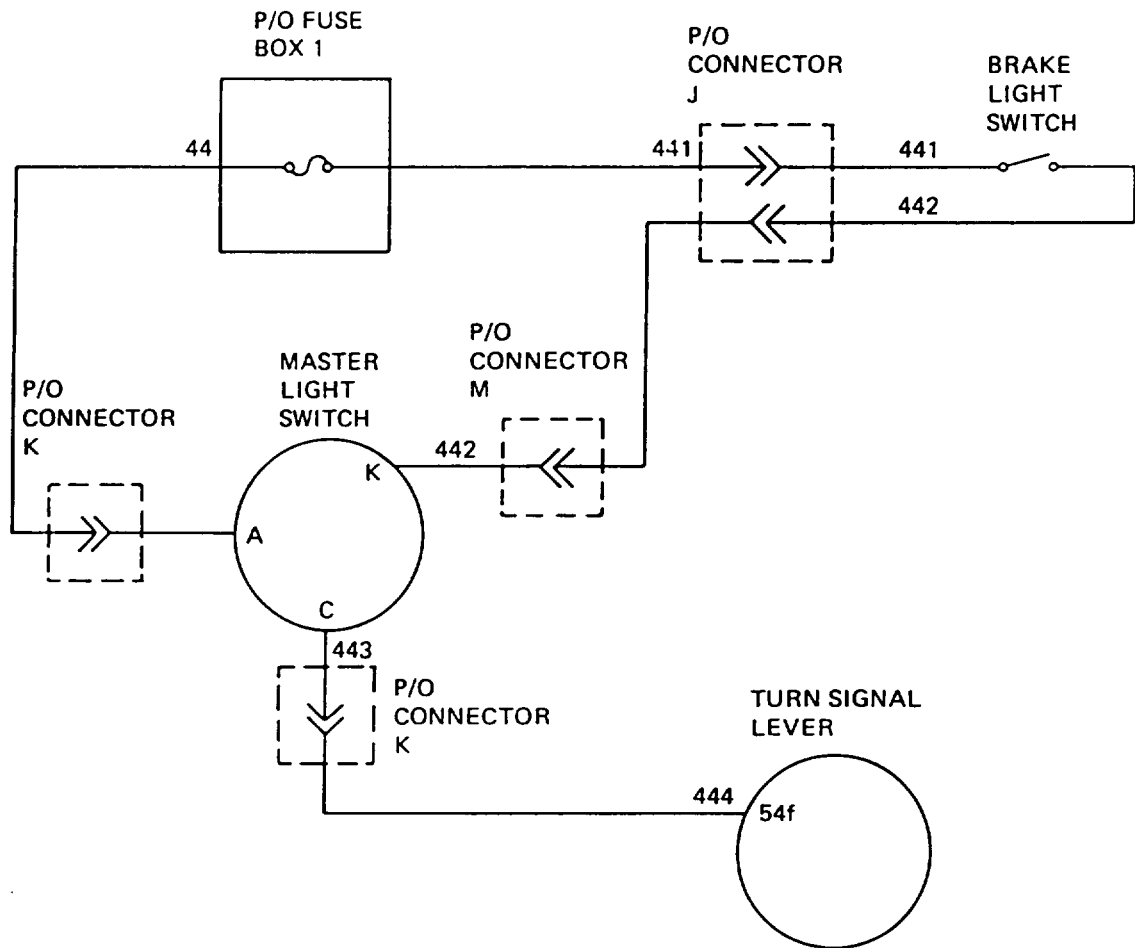

Table 3-5. Troubleshooting (Cont)

Malfunction

Test or Inspection

Corrective Action

ELECTRICAL SYSTEM (CONT)

61. RIGHT BRAKE LIGHT WILL NOT LIGHT.

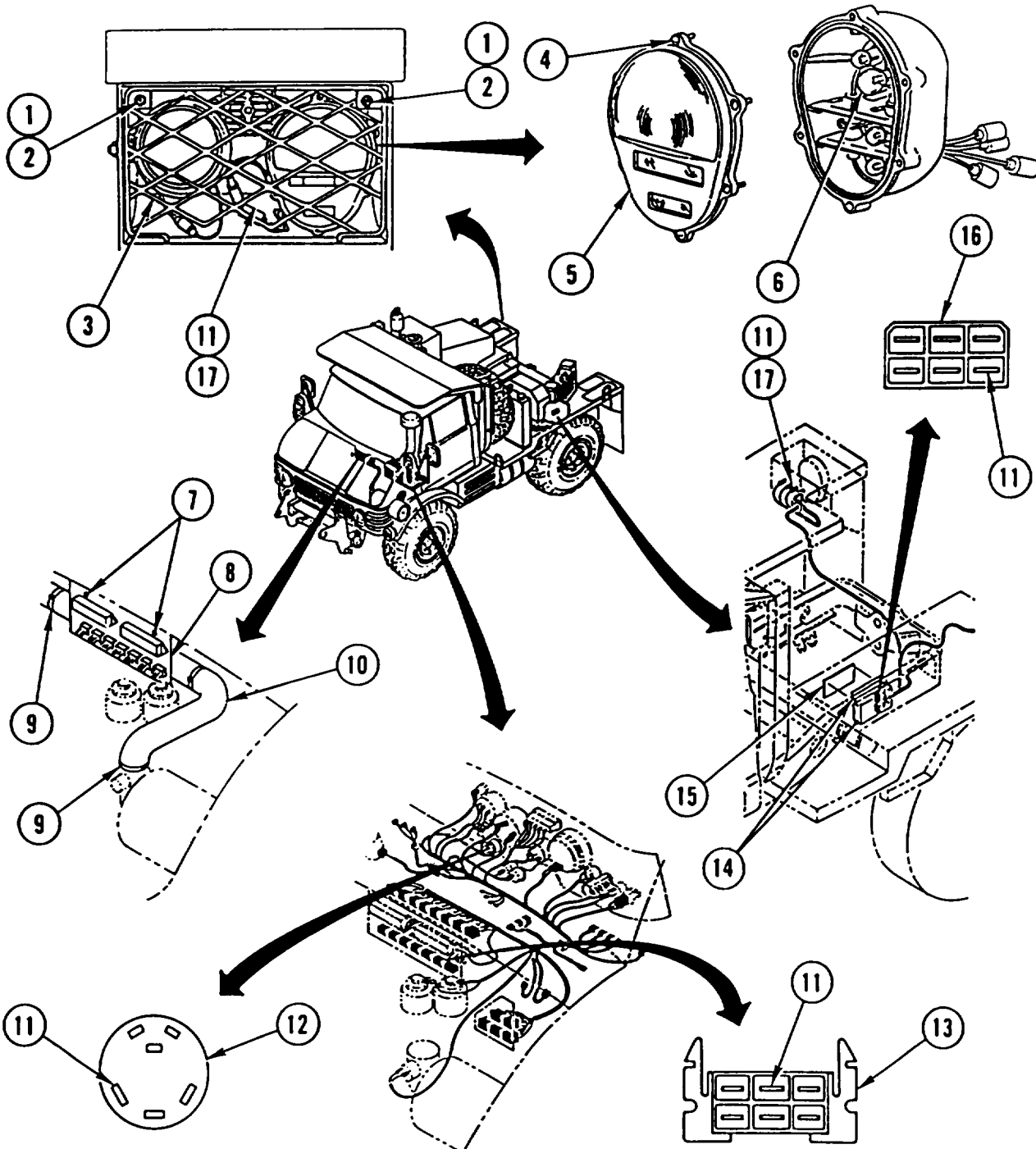

Table 3-5. Troubleshooting (Cont)

Malfunction	Test or Inspection	Corrective Action
ELECTRICAL SYSTEM (CONT)		
NOTE		
		<ul style="list-style-type: none"> • Vehicle MASTER disconnect switch must be ON, master light switch set to SER DRIVE, and turn signal lever off. Failure to do so will cause erroneous results. • Refer to wiring diagram (page 3-194) for all wiring repair steps. <ul style="list-style-type: none"> Step 1. Remove two screws (1), two washers (2), and guard (3). Loosen six screws (4) and remove retainer (5) Step 2. Remove brake lamp (6) and check for continuity. <ul style="list-style-type: none"> • if there is • if there is Step 3. Loosen two captive screws (7) and pull bracket (8) out enough to gain access to area behind bracket. Step 4. Remove two clamps (9) and pipe assembly (10). Step 5. Check for +24 VDC between wire 4445R (11) and ground at turn signal lever (12). <ul style="list-style-type: none"> • If +24 VDC is not present, replace turn signal lever (page 4-122). • If +24 VDC is present, go to step 6. Step 6. Disconnect connector B (13) and check for +24 VDC between wire 4445R (11) and ground. <ul style="list-style-type: none"> • If +24 VDC is not present, repair wiring 4445R between connector B and turn signal lever. • If +24 VDC is present, reconnect connector B and go to step 7. Step 7. Release two clamps (14) and remove cover (15). Step 8. Disconnect connector Y (16) and check for +24 VDC between wire 4445R (11) and ground. <ul style="list-style-type: none"> • If +24 VDC is not present, repair wiring 4445R between connector Y and connector B. • If +24 VDC is present, reconnect connector Y and go to step 9.

Table 3-5. Troubleshooting (Cont)

Malfunction	Test or Inspection	Corrective Action
-------------	--------------------	-------------------

ELECTRICAL SYSTEM (CONT)

Step 9. Check for +24 VDC between wire 4445R (11) and ground at right brake light connector (17).

- If +24 VDC is present, replace rear composite stoplight/taillight (page 4-190).
- If +24 VDC is not present, repair wiring 4445R between brake light connector and connector Y.

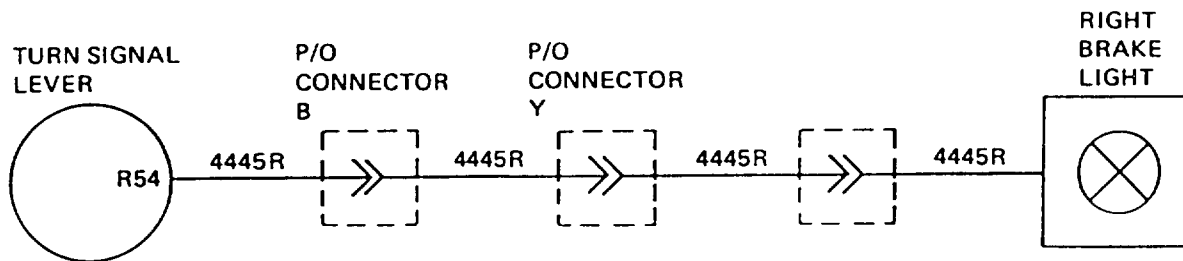

62. RIGHT TAILLIGHT WILL NOT LIGHT.

NOTE

- Vehicle MASTER disconnect switch must be ON and master light switch set to STOP LIGHT. Failure to do so will cause erroneous results.
- Refer to wiring diagram (page 3-196) for all wiring repair steps.

Step 1. Remove two screws (1), two washers (2), and guard (3). Loosen six screws (4) and remove retainer (5).

Step 2. Remove right tail lamp (6) and check for continuity.

- If there is no continuity, replace lamp.
- If there is continuity, go to step 3.

Step 3. Disconnect connector B (7) and check for +24 VDC between wire 41TR (8) and ground.

- If +24 VDC is not present, repair wiring 41TR between connector B and fuse box 2.
- If +24 VDC is present, reconnect connector B and go to step 4.

Step 4. Disconnect connector Y (9) and check for +24 VDC between wire 41TR (8) and ground.

- If +24 VDC is not present, repair wiring 41TR between connector Y and connector B.
- If +24 VDC is present, reconnect connector Y and go to step 5.

Table 3-5. Troubleshooting (Cont)

Malfunction	Test or Inspection	Corrective Action
-------------	--------------------	-------------------

ELECTRICAL SYSTEM (CONT)

Step 5. Check for +24 VDC between wire 41TR (8) and ground at right taillight connector (10).

- If +24 VDC is present, replace rear composite stoplight/taillight (page 4-190).
- If +24 VDC is not present, repair wiring 41TR between right taillight connector and connector Y.

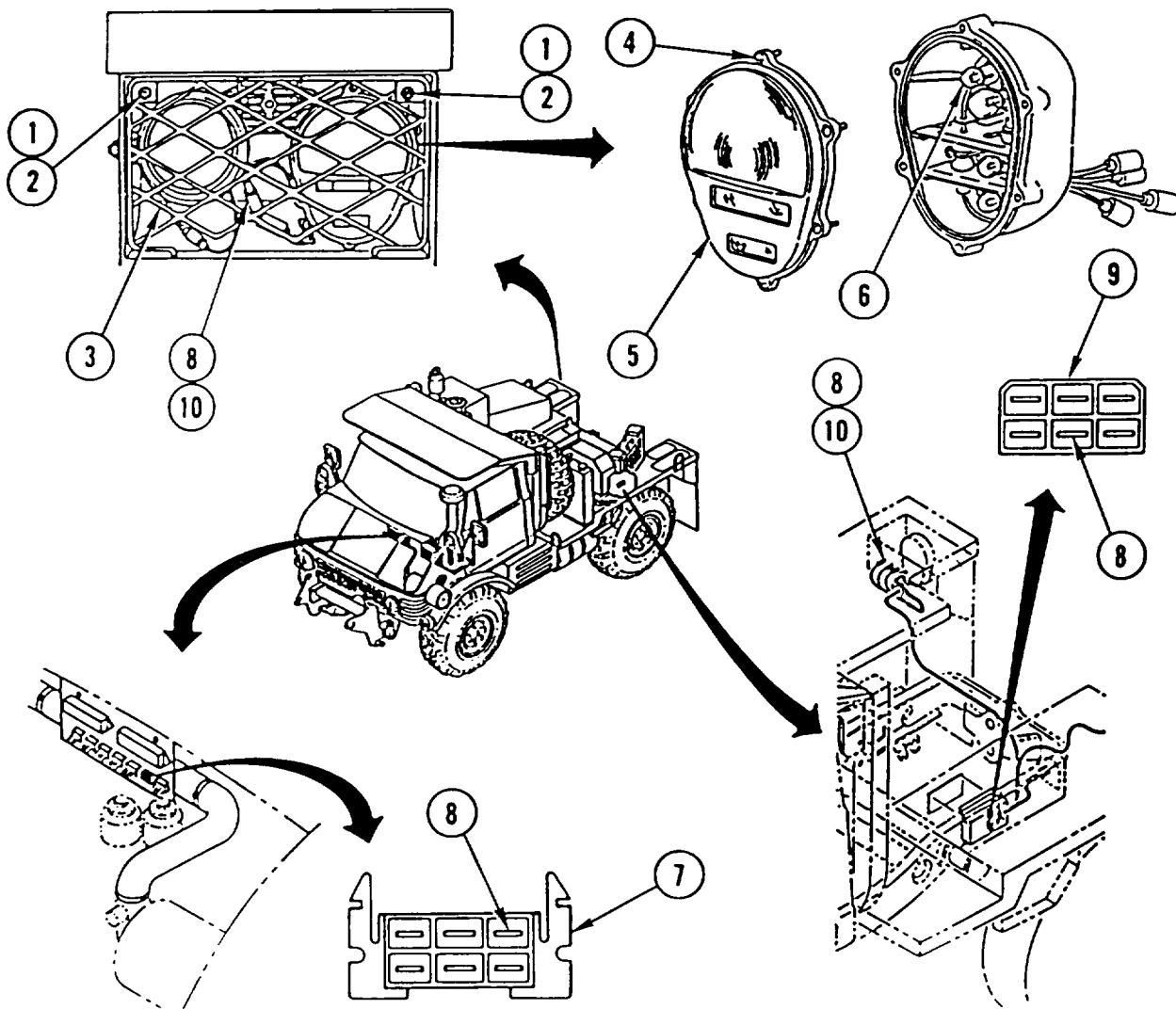
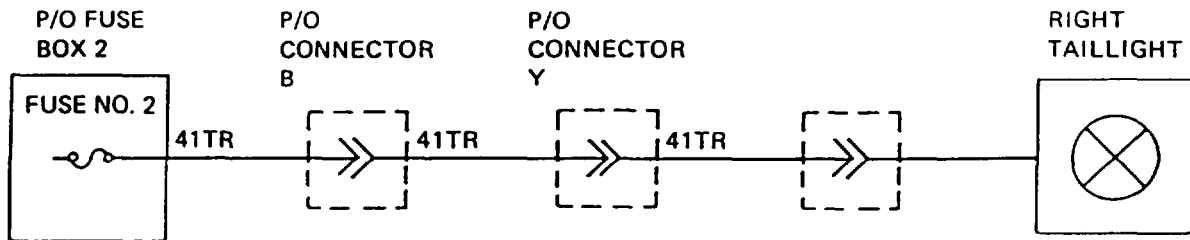

Table 3-5. Troubleshooting (Cont)

Malfunction	Test or Inspection	Corrective Action
-------------	--------------------	-------------------

ELECTRICAL SYSTEM (CONT)



63. RIGHT BLACKOUT TAILLIGHT WILL NOT LIGHT.

NOTE

- Vehicle MASTER disconnect switch must be ON and master light switch set to 60 DRIVE. Failure to do so will cause erroneous results.
- Refer to wiring diagram for all wiring repair steps.

Step 1. Remove two screws (1), two washers (2), and guard (3). Loosen six screws (4) and remove retainer (5).

Step 2. Remove right blackout tail lamp (6) and check for continuity.

- If there is no continuity, replace lamp.
- If there is continuity, go to step 3.

Step 3. Disconnect connector B (7) and check for +24 VDC between wire 48 (8) and ground.

- If +24 VDC is not present, repair wiring 48 between connector B and fuse box 1.
- If +24 VDC is present, reconnect connector B and go to step 4.

Step 4. Disconnect connector Y (9) and check for +24 VDC between wire 48 (8) and ground.

- If +24 VDC is not present, repair wiring 48 between connector Y and connector B.
- If +24 VDC is present, reconnect connector Y and go to step 5.

Step 5. Check for +24 VDC between wire 48 (8) and ground at right blackout taillight connector (10).

- If +24 VDC is present, replace rear composite stoplight/taillight (page 4-190).
- If +24 VDC is not present, repair wiring 48 between right blackout taillight connector and connector Y.

Table 3-5. Troubleshooting (Cont)

Malfunction	Test or Inspection	Corrective Action
-------------	--------------------	-------------------

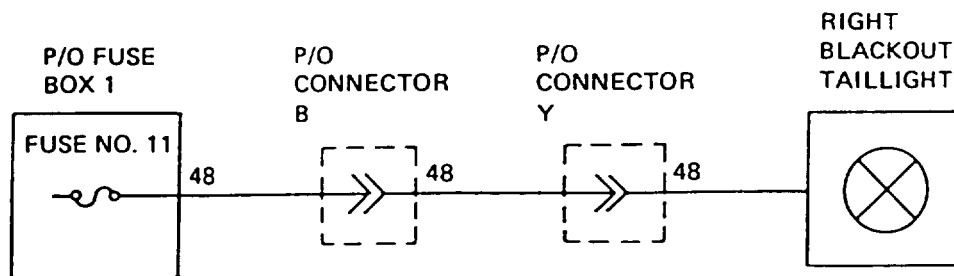
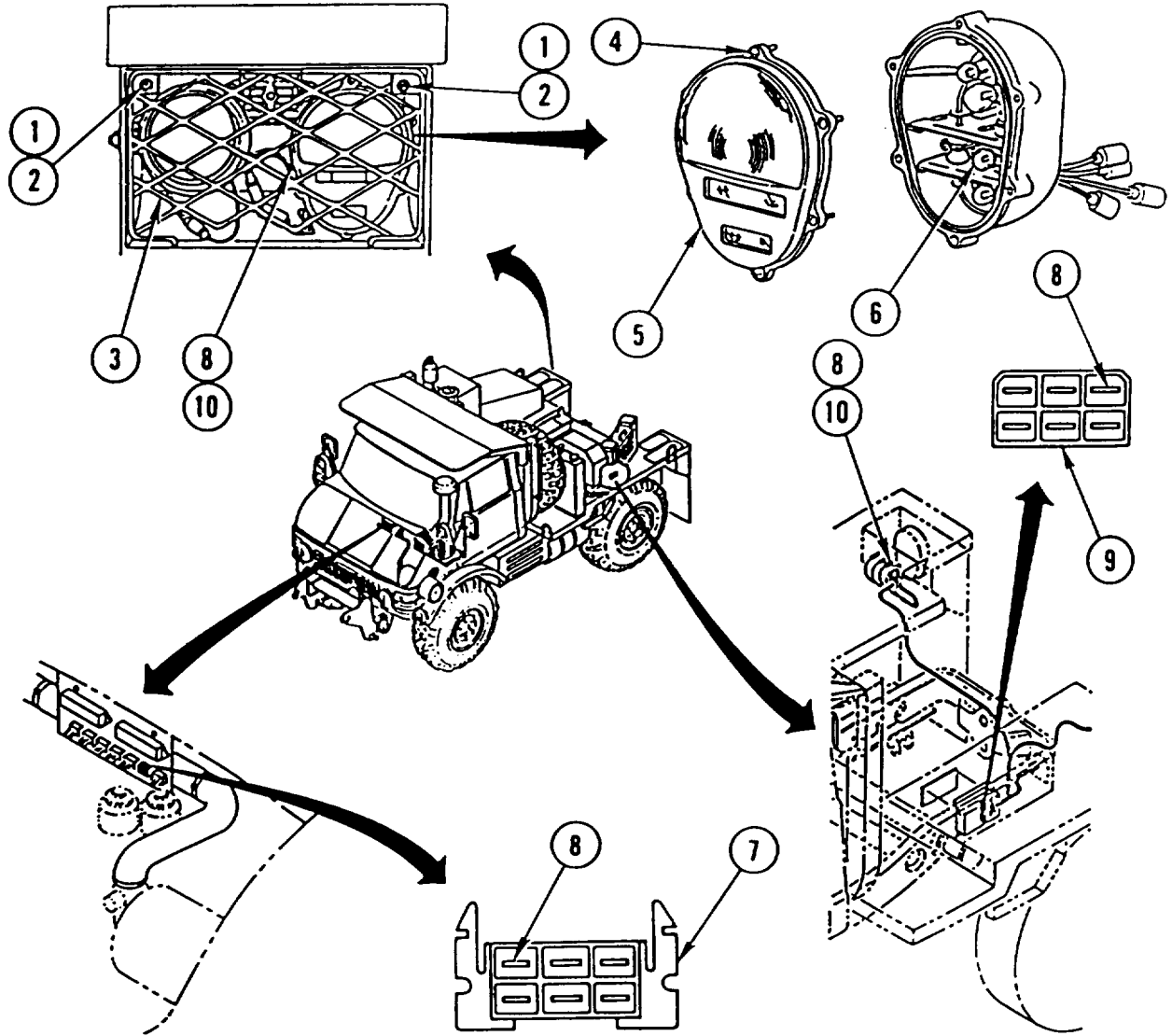

Table 3-5. Troubleshooting (Cont)

Malfunction	Test or Inspection	Corrective Action
-------------	--------------------	-------------------

ELECTRICAL SYSTEM (CONT)

64. RIGHT BLACKOUT BRAKE LIGHT WILL NOT LIGHT.

NOTE

- Vehicle MASTER disconnect switch must be ON and master light switch set to BO DRIVE. Failure to do so will cause erroneous results.
- Refer to wiring diagram (page 3-200) for all wiring repair steps.

Step 1. Remove two screws (1), two washers (2), and guard (3). Loosen six screws (4) and remove retainer (5).

Step 2. Remove right blackout brake lamp (6) and check for continuity.

- If there is no continuity, replace lamp.
- If there is continuity, go to step 3.

Step 3. Disconnect connector B (7) and check for +24 VDC between wire 47 (8) and ground.

- If +24 VDC is not present, reconnect connector B and go to step 6.
- If +24 VDC is present, reconnect connector B and go to step 4.

Step 4. Disconnect connector Y (9) and check for +24 VDC between wire 47 (8) and ground.

- If +24 VDC is not present, repair wiring 47 between connector Y and connector B.
- If +24 VDC is present, reconnect connector Y and go to step 5.

Step 5. Check for +24 VDC between wire 47 (8) and ground at right blackout brake light connector (10).

- If +24 VDC is present, replace rear composite stoplight/taillight (page 4-190).
- If +24 VDC is not present, repair wiring 47 between right blackout brake light connector and connector Y.

Step 6. Loosen two captive screws (11) and pull bracket (12) out enough to gain access to area behind bracket.

Step 7. Remove two clamps (13) and pipe assembly (14).

Step 8. Disconnect connector M (15) and check for +24 VDC between wire 47 (8) and ground.

- If +24 VDC is present, repair wiring 47 between connector M and connector B.
- If +24 VDC is not present, reconnect connector M and go to step 9.

Table 3-5. Troubleshooting (Cont)

Malfunction	Test or Inspection	Corrective Action
-------------	--------------------	-------------------

ELECTRICAL SYSTEM (CONT)

Step 9. Check for +24 VDC between wire 47 (8) and ground at master light switch connector (16).

- If +24 VDC is not present, replace master light switch (page 4-137).
- If +24 VDC is present, repair wiring 47 between master light switch connector and connector M.

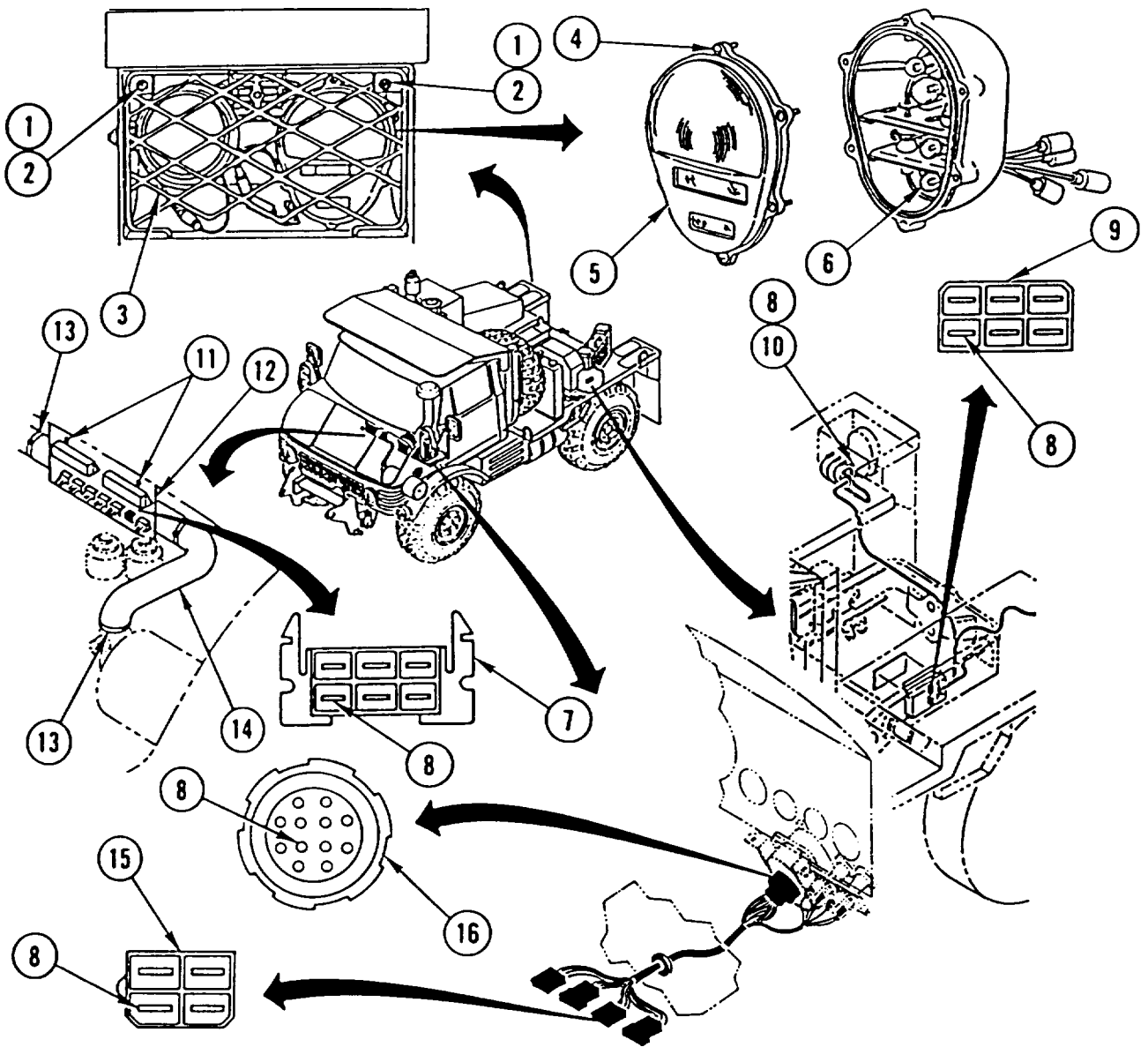
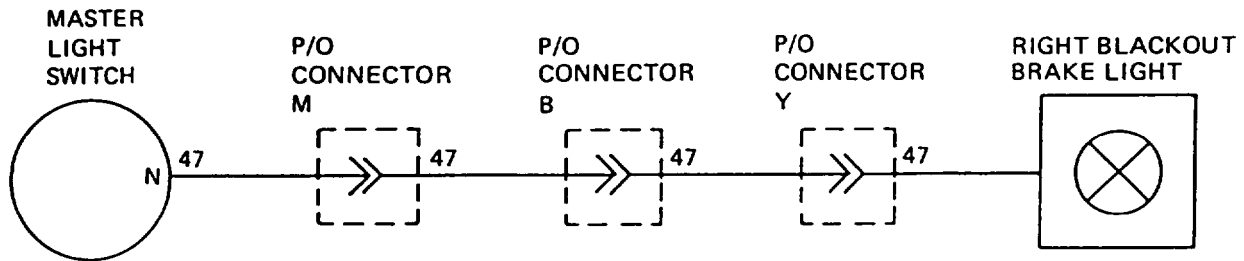

Table 3-5. Troubleshooting (Cont)

Malfunction	Test or Inspection	Corrective Action
-------------	--------------------	-------------------

ELECTRICAL SYSTEM (CONT)



65. LEFT BRAKE LIGHT WILL NOT LIGHT.

NOTE

- Vehicle MASTER disconnect switch must be ON, master light switch set to SER DRIVE, and turn signal lever off. Failure to do so will cause erroneous results.
- Refer to wiring diagram (page 3-202) for all wiring repair steps.

Step 1. Remove two screws (1), two washers (2), and guard (3). Loosen six screws (4) and remove retainer (5).

Step 2. Remove left brake lamp (6) and check for continuity.

- If there is no continuity, replace lamp.
- If there is continuity, go to step 3.

Step 3. Loosen two captive screws (7) and pull bracket (8) out enough to gain access to area behind bracket.

Step 4. Remove two clamps (9) and pipe assembly (10).

Step 5. Check for +24 VDC between wire 4445L (11) and ground at turn signal lever (12).

- If +24 VDC is not present, replace turn signal lever (page 4-122).
- If +24 VDC is present, go to step 6.

Step 6. Disconnect connector B (13) and check for +24 VDC between wire 4445L (11) and ground.

- If +24 VDC is not present, repair wiring 4445L between connector B and turn signal lever.
- If +24 VDC is present, reconnect connector B and go to step 7.

Table 3-5. Troubleshooting (Cont)

Malfunction	Test or Inspection	Corrective Action
-------------	--------------------	-------------------

ELECTRICAL SYSTEM (CONT)

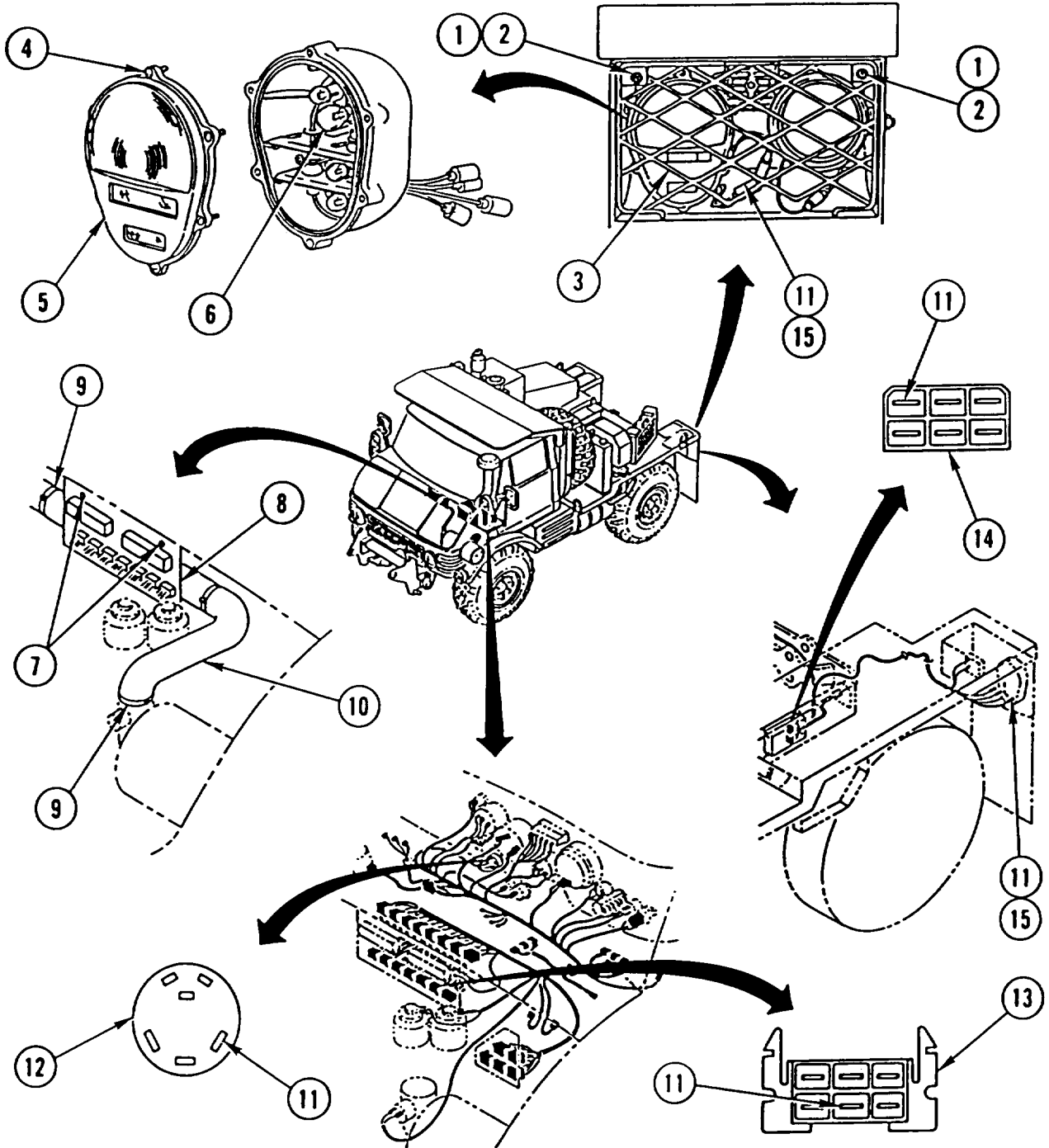

Table 3-5. Troubleshooting (Cont)

Malfunction	Test or Inspection	Corrective Action
-------------	--------------------	-------------------

ELECTRICAL SYSTEM (CONT)

Step 7. Disconnect connector Y (14) and check for +24 VDC between wire 4445L (11) and ground.

- If +24 VDC is not present, repair wiring 4445L between connector Y and connector B.
- If +24 VDC is present, reconnect connector Y and go to step 8.

Step 8. Check for +24 VDC between wire 4445L (11) and ground at left brake light connector (15).

- If +24 VDC is present, replace rear composite stoplight/taillight (page 4-190).
- If +24 VDC is not present, repair wiring 4445L between left brake light connector and connector Y.

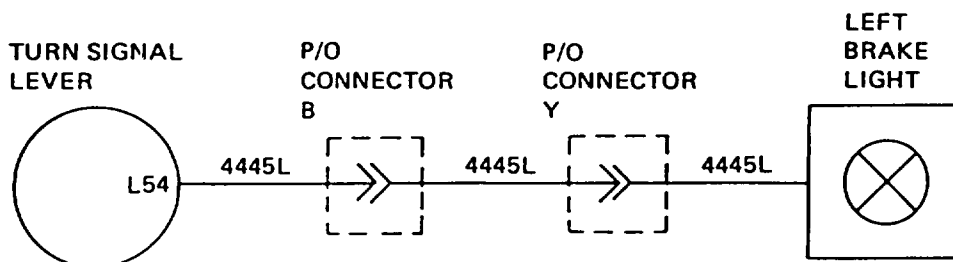

66. LEFT TAILLIGHT WILL NOT LIGHT.

NOTE

- Vehicle MASTER disconnect switch must be ON and master light switch set to STOP LIGHT. Failure to do so will cause erroneous results.
- Refer to wiring diagram (page 3-204) for all wiring repair steps.

Step 1. Remove two screws (1), two washers (2), and guard (3). Loosen six screws (4) and remove retainer (5).

Step 2. Remove left tail lamp (6) and check for continuity.

- If there is no continuity, replace lamp.
- If there is continuity, go to step 3.

Table 3-5. Troubleshooting (Cont)

Malfunction	Test or Inspection	Corrective Action
ELECTRICAL SYSTEM (CONT)		
	Step 3. Disconnect connector B (7) and check for +24 VDC between wire 41TL (8) and ground.	<ul style="list-style-type: none"> • If +24 VDC is not present, repair wiring 41TL between connector B and fuse box 2. • If +24 VDC is present, reconnect connector B and go to step 4.
	Step 4. Disconnect connector Y (9) and check for +24 VDC between wire 41TL (8) and ground.	<ul style="list-style-type: none"> • If +24 VDC is not present, repair wiring 41TL between connector Y and connector B. • If +24 VDC is present, reconnect connector Y and go to step 5.
	Step 5. Check for +24 VDC between wire 41TL (8) and ground at left taillight connector (10).	<ul style="list-style-type: none"> • If +24 VDC is present, replace rear composite stoplight/taillight (page 4-190). • If +24 VDC is not present, repair wiring 41TL between left taillight connector and connector Y.

Table 3-5. Troubleshooting (Cont)

Malfunction	Test or Inspection	Corrective Action
-------------	--------------------	-------------------

ELECTRICAL SYSTEM (CONT)

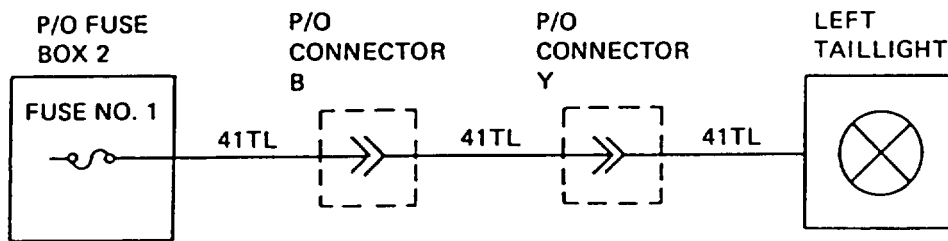
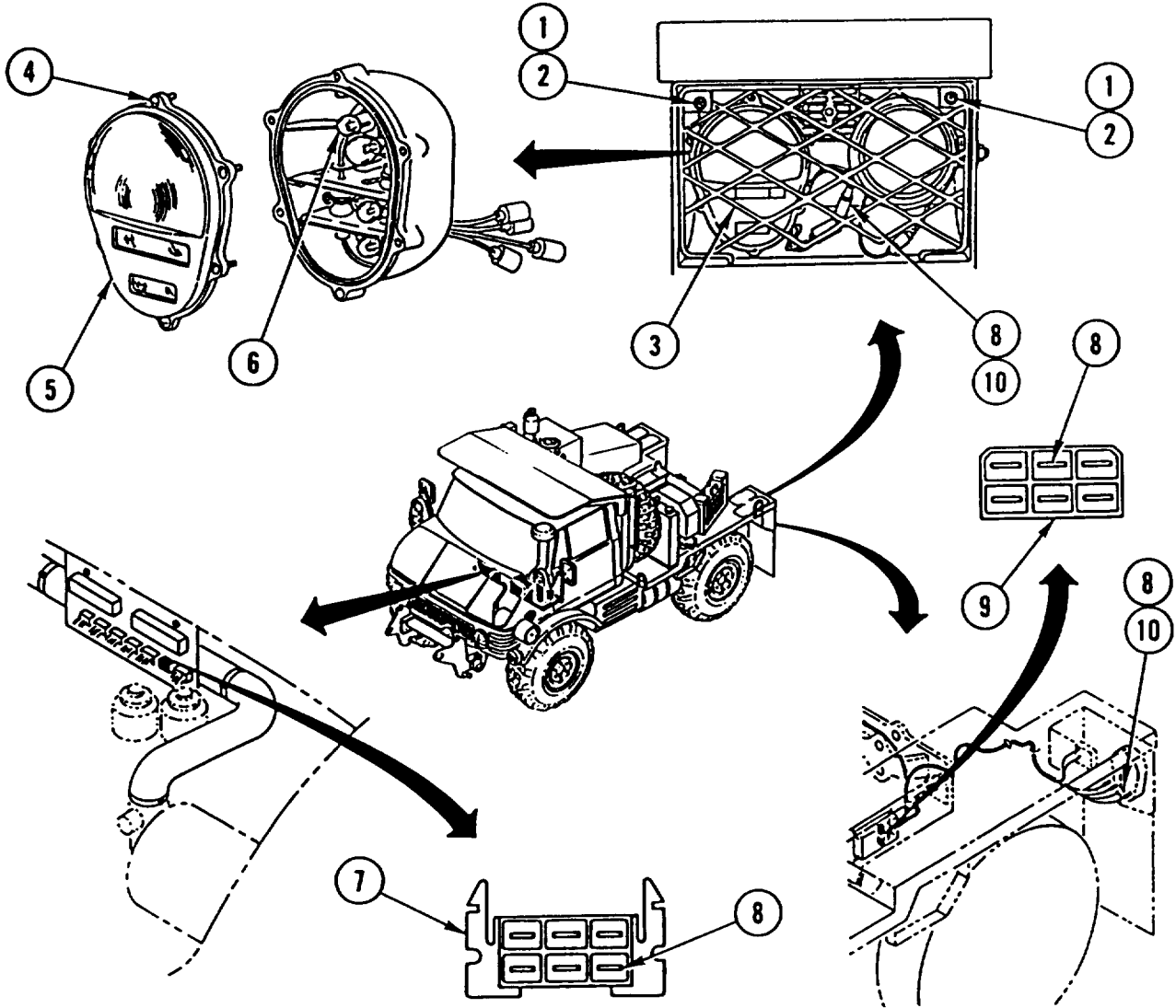

Table 3-5. Troubleshooting (Cont)

Malfunction	Test or Inspection	Corrective Action
ELECTRICAL SYSTEM (CONT)		
67. LEFT BLACKOUT TAILLIGHT WILL NOT LIGHT.		
NOTE		
<ul style="list-style-type: none"> <li data-bbox="310 566 1435 623">• Vehicle MASTER disconnect switch must be ON and master light switch set to BO DRIVE. Failure to do so will cause erroneous results. <li data-bbox="310 644 1175 670">• Refer to wiring diagram (page 3-206) for all wiring repair steps. <ul style="list-style-type: none"> <li data-bbox="363 704 1507 761">Step 1. Remove two screws (1), two washers (2), and guard (3). Loosen six screws (4) and remove retainer (5). <li data-bbox="363 804 1273 923">Step 2. Remove left blackout tail lamp (6) and check for continuity. <ul style="list-style-type: none"> <li data-bbox="613 853 1170 878">• If there is no continuity, replace lamp. <li data-bbox="613 900 1127 925">• If there is continuity, go to step 3. <li data-bbox="363 959 1458 1140">Step 3. Disconnect connector B (7) and check for +24 VDC between wire 48 (8) and ground. <ul style="list-style-type: none"> <li data-bbox="613 1038 1360 1095">• If +24 VDC is not present, repair wiring 48 between connector B and fuse box 1. <li data-bbox="613 1117 1528 1142">• If +24 VDC is present, reconnect connector B and go to step 4. <li data-bbox="363 1176 1528 1357">Step 4. Disconnect connector Y (9) and check for +24 VDC between wire 48 (8) and ground. <ul style="list-style-type: none"> <li data-bbox="613 1257 1360 1315">• If +24 VDC is not present, repair wiring 48 between connector Y and connector B. <li data-bbox="613 1336 1528 1361">• If +24 VDC is present, reconnect connector Y and go to step 5. <li data-bbox="363 1391 1507 1604">Step 5. Check for +24 VDC between wire 48 (8) and ground at left blackout taillight connector (10). <ul style="list-style-type: none"> <li data-bbox="613 1470 1500 1527">• If +24 VDC is present, replace rear composite stoplight/taillight (page 4-190). <li data-bbox="613 1549 1419 1606">• If +24 VDC is not present, repair wiring 48 between left blackout taillight connector and connector Y. 		

Table 3-5. Troubleshooting (Cont)

Malfunction

Test or Inspection

Corrective Action

ELECTRICAL SYSTEM (CONT)

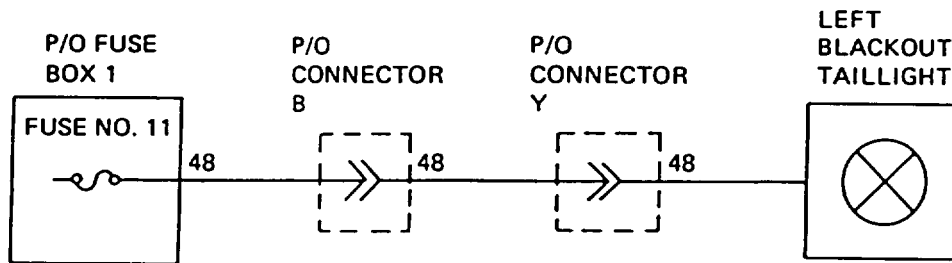
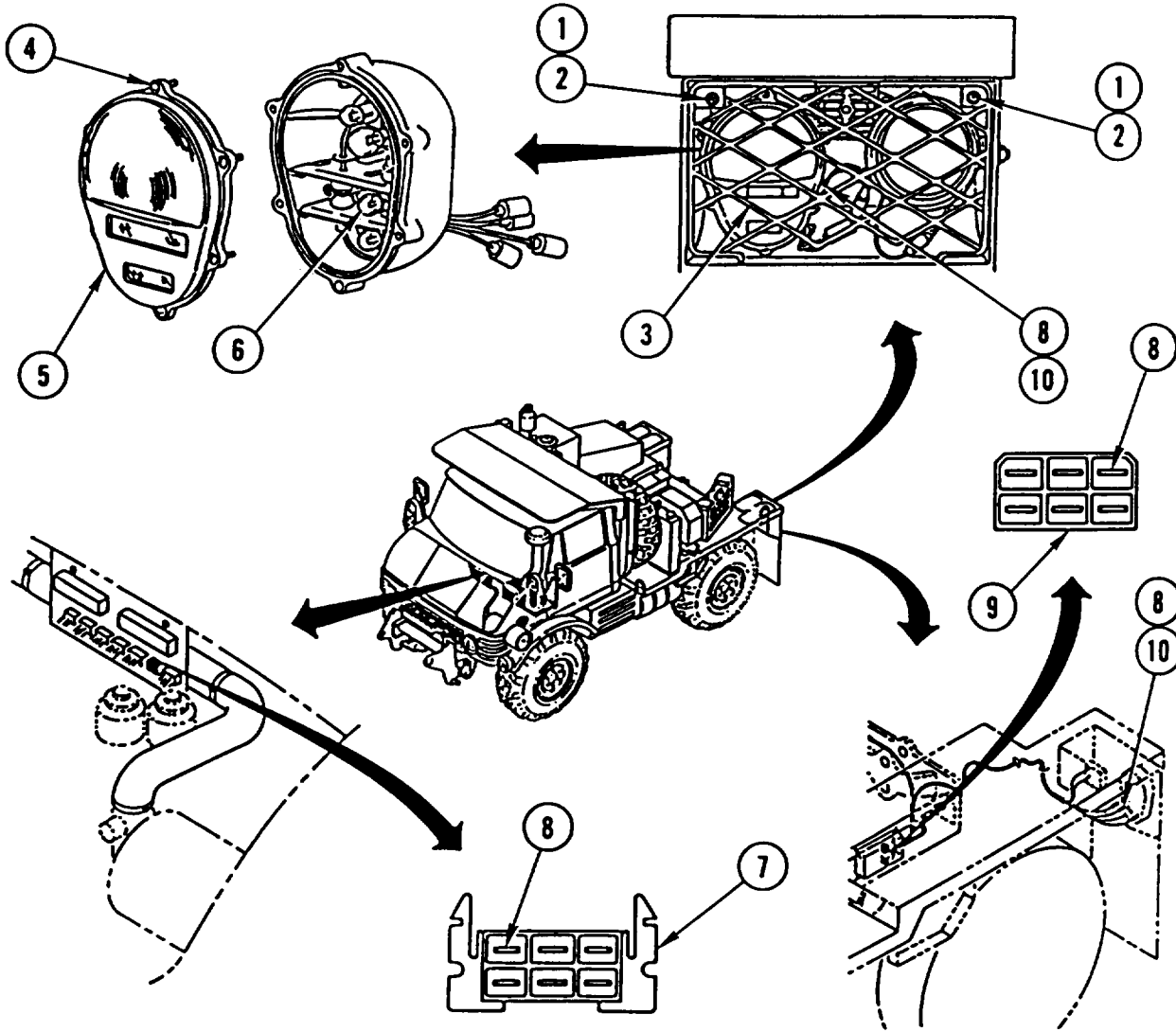

Table 3-5. Troubleshooting (Cont)

Malfunction	Test or Inspection	Corrective Action
ELECTRICAL SYSTEM (CONT)		
68. LEFT BLACKOUT BRAKE LIGHT WILL NOT LIGHT.		
NOTE		
<ul style="list-style-type: none"> • Vehicle MASTER disconnect switch must be ON and master light switch set to BO DRIVE. Failure to do so will cause erroneous results. • Refer to wiring diagram (page 3-209) for all wiring repair steps. 		
<p>Step 1. Remove two screws (1), two washers (2), and guard (3). Loosen six screws (4) and remove retainer (5).</p>		
<p>Step 2. Remove left blackout brake lamp (6) and check for continuity.</p> <ul style="list-style-type: none"> • If there is no continuity, replace lamp. • If there is continuity, go to step 3. 		
<p>Step 3. Disconnect connector B (7) and check for +24 VDC between wire 47 (8) and ground.</p> <ul style="list-style-type: none"> • If +24 VDC is present, reconnect connector B and go to step 4. • If +24 VDC is not present, reconnect connector B and go to step 6. 		
<p>Step 4. Disconnect connector Y (9) and check for +24 VDC between wire 47 (8) and ground.</p> <ul style="list-style-type: none"> • If +24 VDC is not present, repair wiring 47 between connector Y and connector B. • If +24 VDC is present, reconnect connector Y and go to step 5. 		
<p>Step 5. Check for +24 VDC between wire 47 (8) and ground at left blackout brake light connector (10).</p> <ul style="list-style-type: none"> • If +24 VDC is not present, repair wiring 47 between left blackout brake light connector and connector Y. • If +24 VDC is present, replace rear composite stoplight/taillight (page 4-190). 		
<p>Step 6. Loosen two captive screws (11) and pull bracket (12) out enough to gain access to area behind bracket.</p>		
<p>Step 7. Remove two clamps (13) and pipe assembly (14).</p>		

Table 3-5. Troubleshooting (Cont)

Malfunction	Test or Inspection	Corrective Action
-------------	--------------------	-------------------

ELECTRICAL SYSTEM (CONT)

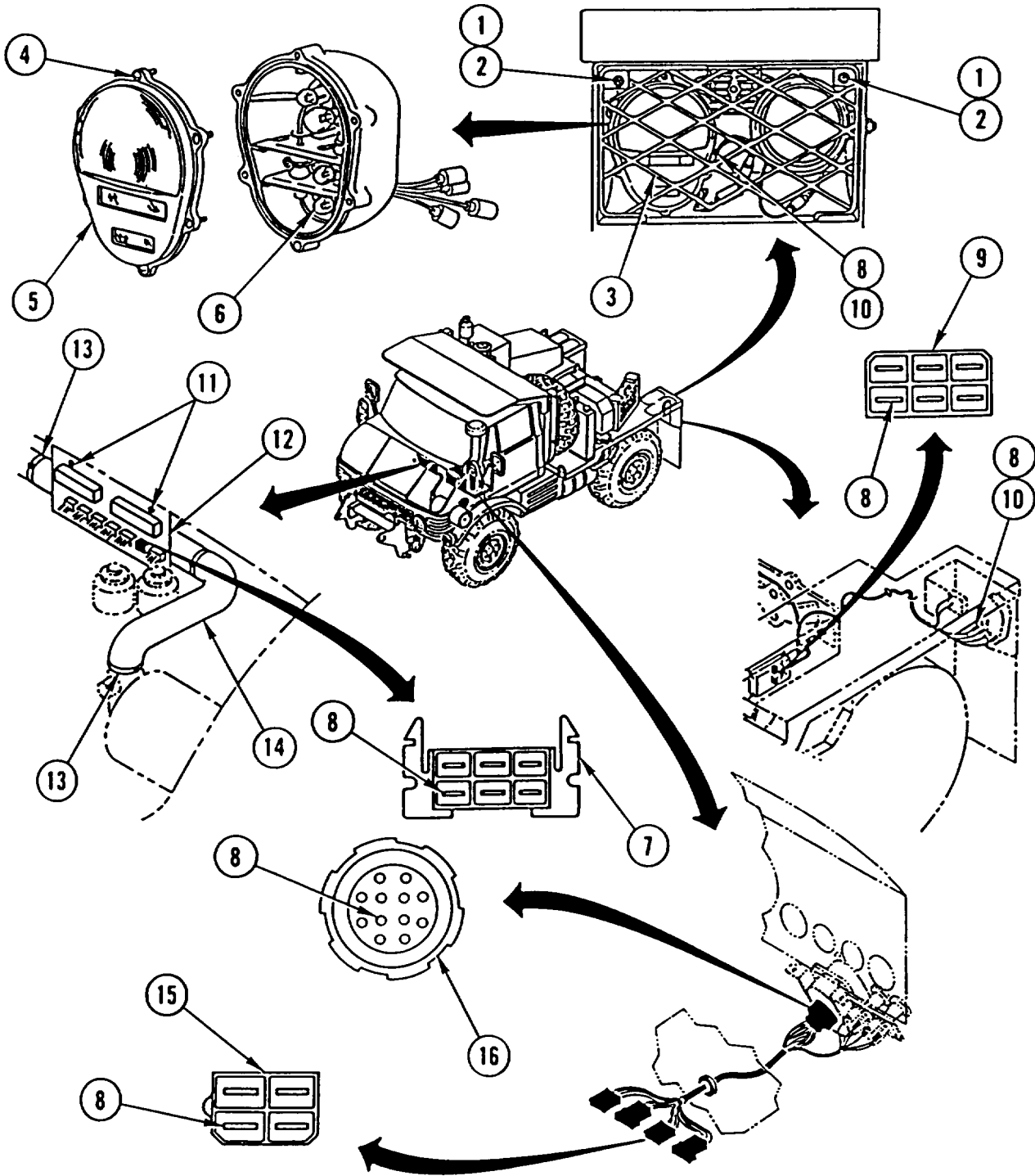

Table 3-5. Troubleshooting (Cont)

Malfunction	Test or Inspection	Corrective Action
-------------	--------------------	-------------------

ELECTRICAL SYSTEM (CONT)

Step 8. Disconnect connector M (15) and check for +24 VDC between wire 47 (8) and ground.

- If +24 VDC is present, repair wiring 47 between connector M and connector B.
- If +24 VDC is not present, reconnect connector M and go to step 9.

Step 9. Check for +24 VDC between wire 47 (8) and ground at master light switch connector (16).

- If +24 VDC is not present, replace master light switch (page 4-137).
- If +24 VDC is present, repair wiring 47 between master light switch connector and connector M.

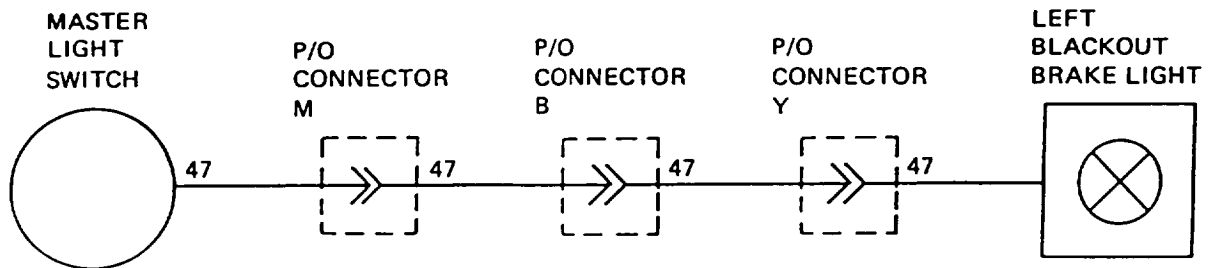

Table 3-5. Troubleshooting (Cont)

Malfunction	Test or Inspection	Corrective Action
-------------	--------------------	-------------------

ELECTRICAL SYSTEM (CONT)

69. WORK LIGHTS WILL NOT LIGHT.

NOTE

- Vehicle MASTER disconnect switch must be ON, ignition switch set to ON, and master light switch set to STOP LIGHT. Failure to do so will cause erroneous results.
- Refer to wiring diagram for all wiring repair steps.

Step 1. Disconnect connector A (1) and check for +24 VDC between wire 421 (2) and ground.

- If +24 VDC is not present, reconnect connector A and go to step 5.
- If +24 VDC is present, reconnect connector A and go to step 2.

Step 2. Disconnect connector X (3) and check for +24 VDC between wire 421 (2) and ground.

- If +24 VDC is not present, repair wiring 421 between connector X and connector A.
- If +24 VDC is present, reconnect connector X and go to step 3

Step 3. Loosen nut (4), remove knob (5) and nut (6), and pull work light switch (7) out of cabinet (8) through opening.

Step 4. Install jumper wire across terminals on work light switch (7) and check if work lights are lit.

- If work lights are not lit, repair wiring 421 between work light switch and work lights.
- If work lights are lit, replace work light switch (page 4-162).

Step 5. Check for +24 VDC between wire 421 (2) and ground at fuse box 1 (9).

- If +24 VDC is not present, replace fuse.
- If +24 VDC is present, repair wiring 421 between fuse box 1 and connector A.

Table 3-5. Troubleshooting (Cont)

Malfunction	Test or Inspection	Corrective Action
-------------	--------------------	-------------------

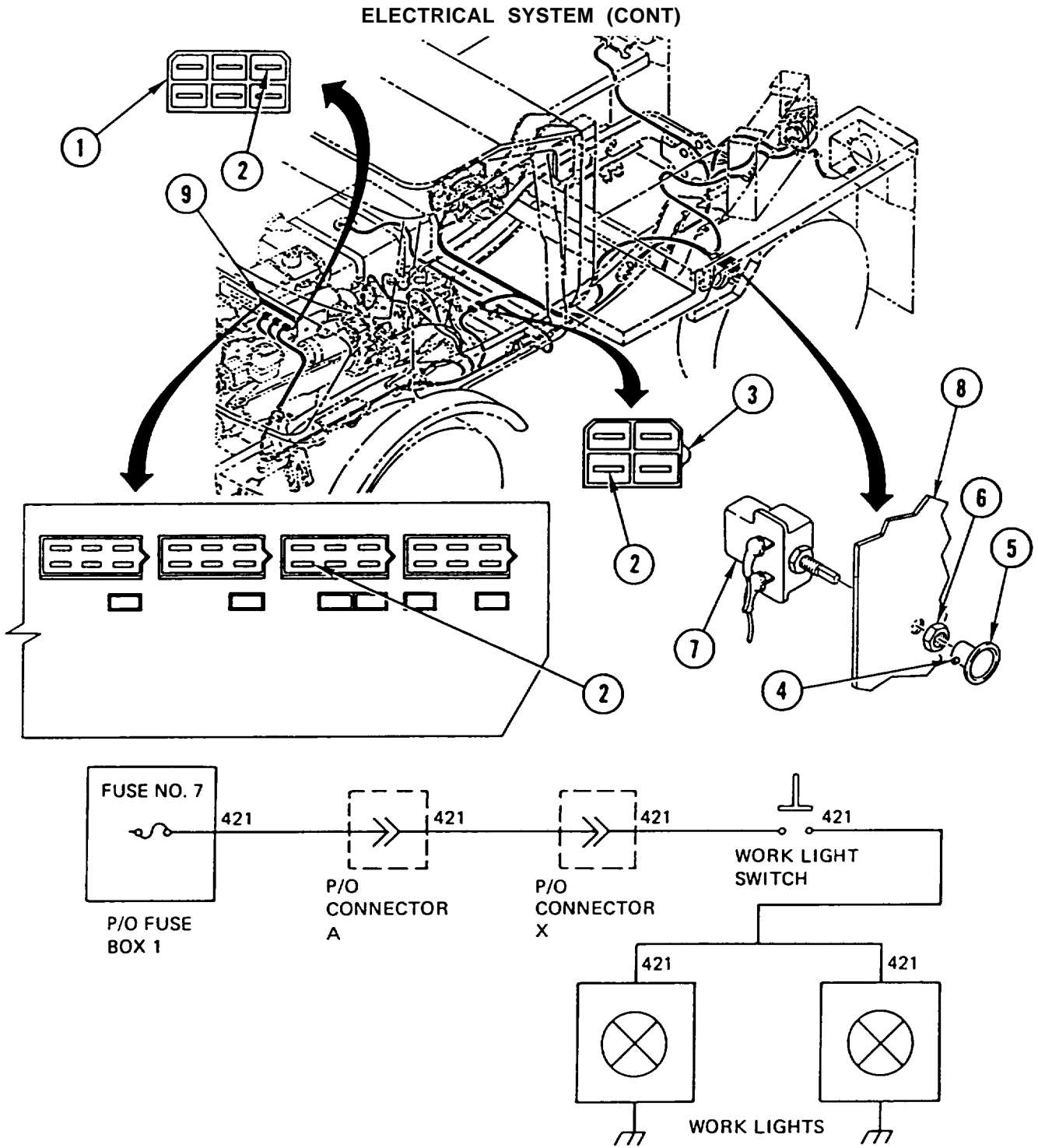

Table 3-5. Troubleshooting (Cont)

Malfunction	Test or Inspection	Corrective Action
-------------	--------------------	-------------------

ELECTRICAL SYSTEM (CONT)

70. BACKUP ALARM WILL NOT SOUND.

NOTE

- Vehicle MASTER disconnect switch must be ON, ignition switch set to ON, and group shift lever shifted to R position. Failure to do so will cause erroneous results.
- Refer to wiring diagram for all wiring repair steps.

Step 1. Disconnect connector A (1) and check for +24 VDC between wire 35R (2) and ground.

- If +24 VDC is present, reconnect connect A and go to
- If +24 VDC is not present, reconnect connector A and go to step 2.

Step 2. Check for +24 VDC between wire 35R (2) and ground at fuse box 1 (3).

- If +24 VDC is not present, replace fuse.
- If +24 VDC is present, repair wiring 35R between fuse box 1 and connector A.

Step 3. Check for +24 VDC between wire 35R (2) and ground at backup alarm switch (4).

- If +24 VDC is not present, repair wiring 35R between connector A and backup alarm switch.
- If +24 VDC is present, go to step 4.

Step 4. Check for +24 VDC between wire 35R1 (5) and ground at backup alarm switch (4).

- If +24 VDC is not present, replace backup alarm switch (page 4-208).
- If +24 VDC is present, go to step 5.

Step 5. Disconnect connector Z (6) and check for +24 VDC between wire 35R1 (5) and ground.

- If +24 VDC is not present, repair wiring 35R1 between connector Z and backup alarm switch.
- If +24 VDC is present, reconnect connector Z and go to step 6.

Step 6. Check for +24 VDC between wire 35R1 (5) and ground at backup alarm (7).

- If +24 VDC is present, replace backup alarm (page 4-214).
- If +24 VDC is not present, repair wiring 35R1 between connector Z and backup alarm.

Table 3-5. Troubleshooting (Cont)

Malfunction	Test or Inspection	Corrective Action
-------------	--------------------	-------------------

ELECTRICAL SYSTEM (CONT)

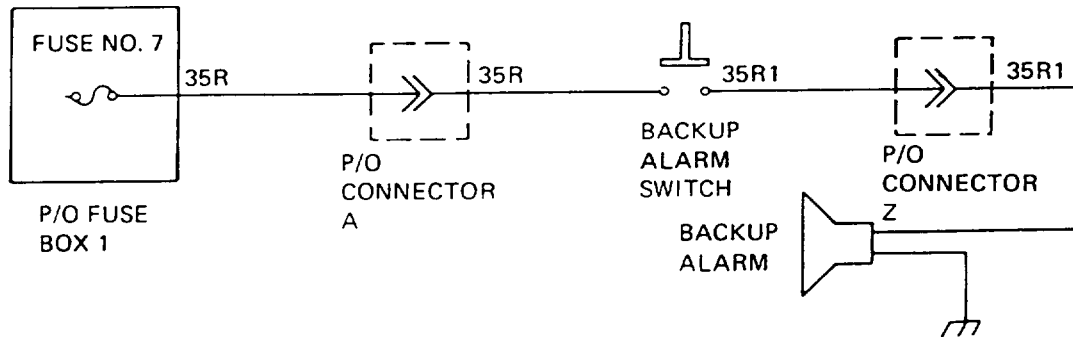
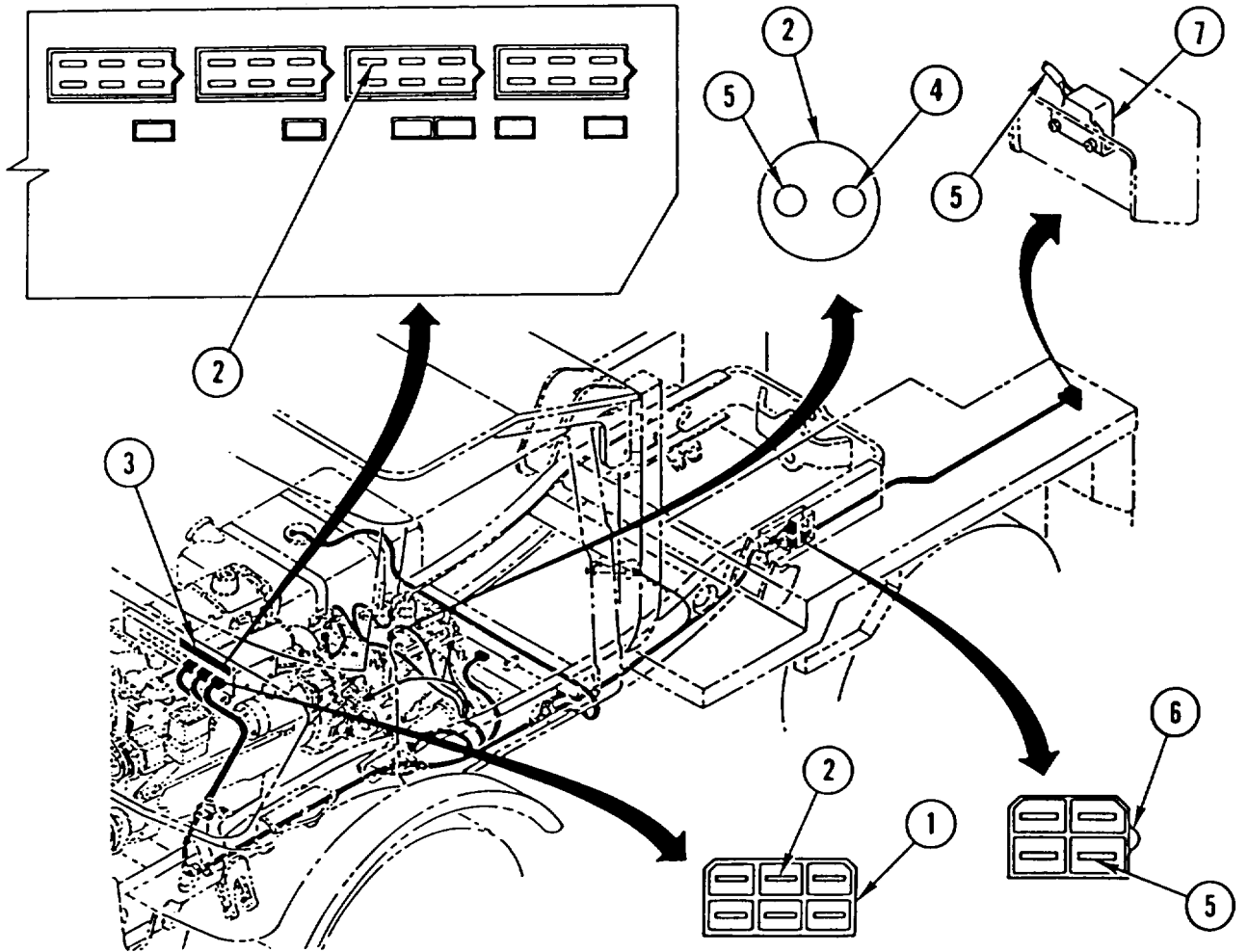

Table 3-5. Troubleshooting (Cont)

Malfunction	Test or Inspection	Corrective Action
-------------	--------------------	-------------------

ELECTRICAL SYSTEM (CONT)

71. LOW OIL PRESSURE AND HIGH WATER TEMPERATURE ALARM WILL NOT SOUND WITH PRESS-TO-TEST SWITCH DEPRESSED.

NOTE

Refer to wiring diagram (page 3-217) for all wiring repair steps.

- Step 1. Depress press-to-test switch (1) and listen for alarm to sound.
 - If alarm sounds, go to step 12.
 - If alarm does not sound, go to step 2.
- Step 2. Disconnect wire 306 (2) and wire 07 (3) and remove nut (4) and press-to-test switch (1).
- Step 3. Check for continuity between terminals of press-to-test switch (1) while pressing button.
 - If there is no continuity, replace press-to-test switch.
 - If there is continuity, install press-to-test switch and go to step 4. _
- Step 4. Disconnect warning delay relay connector (5) and check for continuity between wire 306 (2) and ground with press-to-test switch (1) depressed.
 - If there is no continuity, repair wiring 306 between warning delay relay and press-to-test switch.
 - If there is continuity, go to step 5.

NOTE

For steps 5 thru 14, engine must be running.

- Step 5. With warning delay relay connector (5) disconnected, check for +24 VDC between wire 343 (6) and ground at warning delay relay connector.
 - If +24 VDC is not present, repair wiring 343 between warning delay relay connector and relay K2.
 - If +24 VDC is present, go to step 6.
- Step 6. With warning delay relay connector (5) disconnected, check for +24 VDC between wire 344 (7) and ground at warning delay relay connector.
 - If +24 VDC is not present, repair wiring 344 at warning delay relay connector.
 - If +24 VDC is present, go to step 7.

Table 3-5. Troubleshooting (Cont)

Malfunction

Test or Inspection

Corrective Action

ELECTRICAL SYSTEM (CONT)

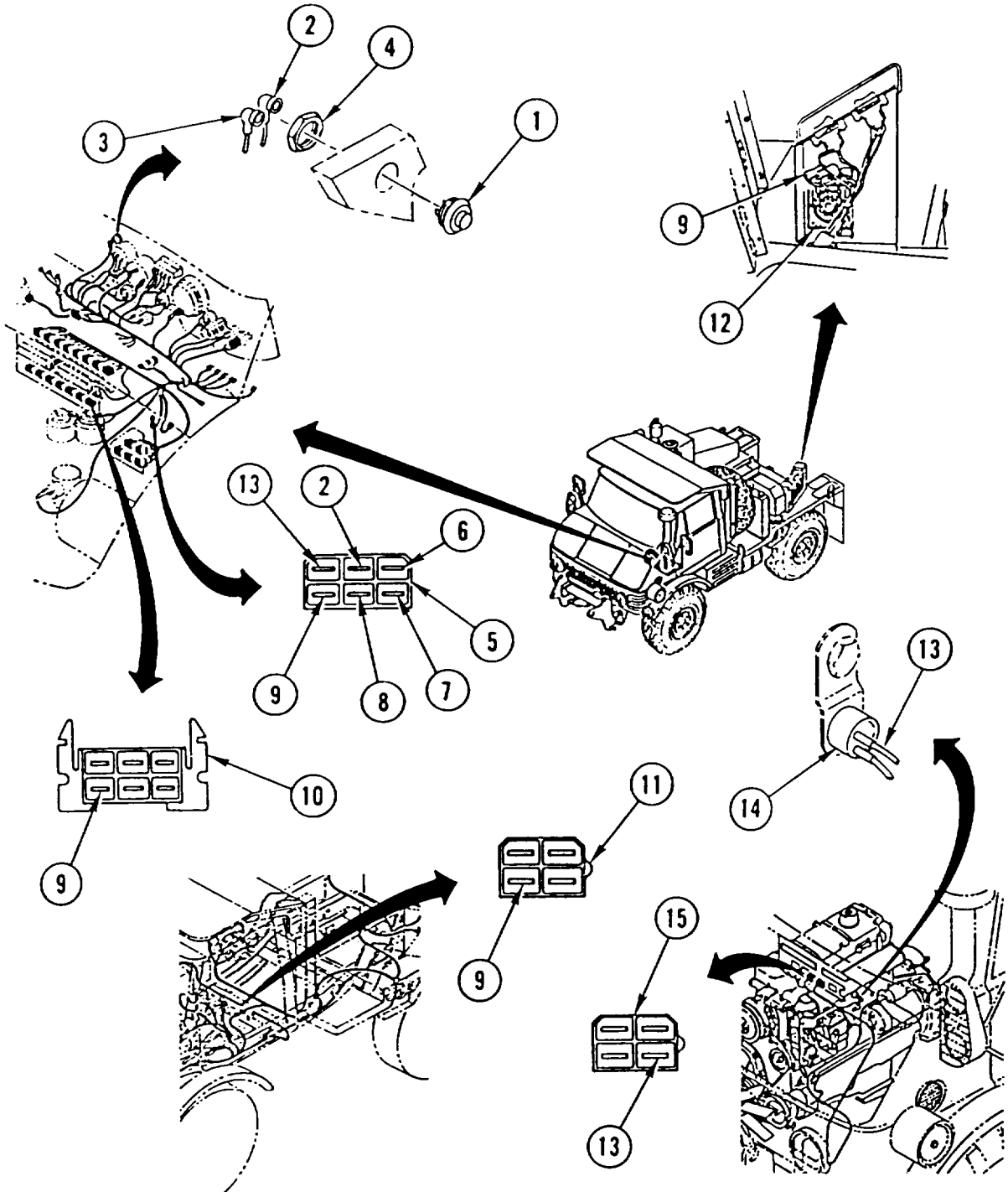

Table 3-5. Troubleshooting (Cont)

Malfunction	Test or Inspection	Corrective Action
ELECTRICAL SYSTEM (CONT)		
Step 7.	With warning delay relay connector (5) disconnected, check for +24 VDC between wire 302 (8) and ground at warning delay relay connector.	<ul style="list-style-type: none"> • If +24 VDC is not present, repair wiring 302 between warning delay relay connector and fuse box 1. • If +24 VDC is present, reconnect warning delay relay connector and go to step 8.
Step 8.	Check for +24 VDC between wire 303 (9) and ground at warning delay relay connector (5).	<ul style="list-style-type: none"> • If +24 VDC is not present, replace warning delay relay (page 4-141). • If +24 VDC is present, go to step 9.
Step 9.	Disconnect connector A (10) and check for +24 VDC between wire 303 (9) and ground.	<ul style="list-style-type: none"> • If +24 VDC is not present, repair wiring 303 between connector A and warning delay relay. • If +24 VDC is present, reconnect connector A and go to step 10.
Step 10.	Disconnect connector X (11) and check for +24 VDC between wire 303 (9) and ground.	<ul style="list-style-type: none"> • If +24 VDC is not present, repair wiring 303 between connector X and connector A. • If +24 VDC is present, reconnect connector X and go to step 11.
Step 11.	Check for +24 VDC between wire 303 (9) and ground at low oil pressure and high water temperature alarm (12).	<ul style="list-style-type: none"> • If +24 VDC is not present, repair wiring 303 between low oil pressure and high water temperature alarm and connector X. • If +24 VDC is present, replace low oil pressure and high water temperature alarm (page 4-170).
Step 12.	Connect jumper between wire 304 (13) and ground at oil pressure sender (14).	
Step 13.	Disconnect warning delay relay connector (5) and check for continuity between wire 304 (13) and ground.	<ul style="list-style-type: none"> • If there is continuity, reconnect warning delay relay connector, remove jumper, and replace oil pressure sender (page 4-202) or water temperature sending unit (page 4-203). • If there is no continuity, reconnect warning delay relay connector and go to step 14.

Table 3-5. Troubleshooting (Cont)

Malfunction	Test or Inspection	Corrective Action
-------------	--------------------	-------------------

ELECTRICAL SYSTEM (CONT)

Step 14. Disconnect connector E (15) and check for continuity between wire 304 (13) and ground.

- If there is continuity, repair wiring 304 between warning delay relay and connector E.
- If there is no continuity, repair wiring 304 between connector E and oil pressure sender.

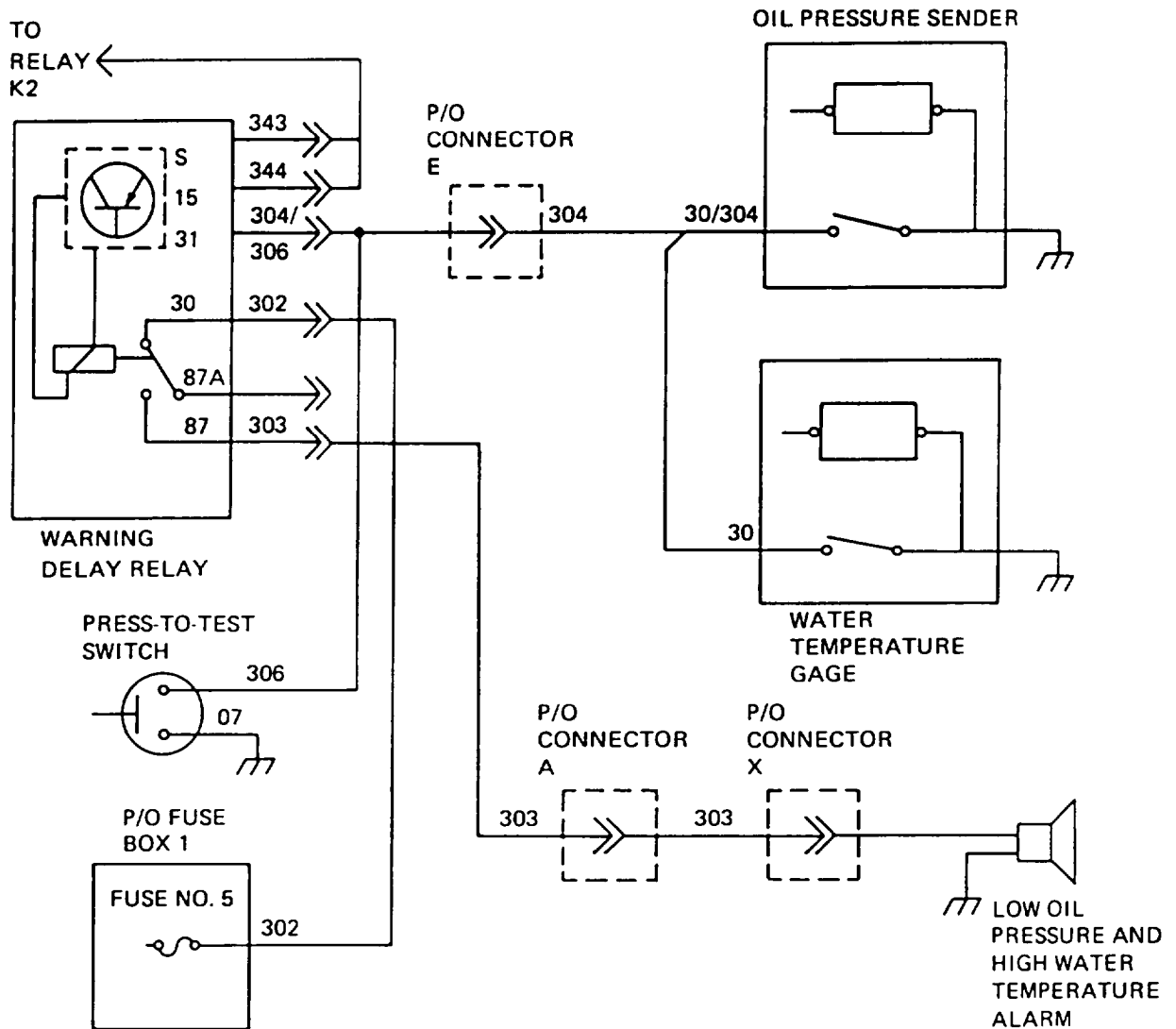

Table 3-5. Troubleshooting (Cont)

Malfunction	Test or Inspection	Corrective Action
-------------	--------------------	-------------------

ELECTRICAL SYSTEM (CONT)

72. Hydraulic Suspension LOCKOUT WILL NOT ENGAGE (HMMH).

NOTE

Electrical quick disconnect for forklift must be connected to vehicle.

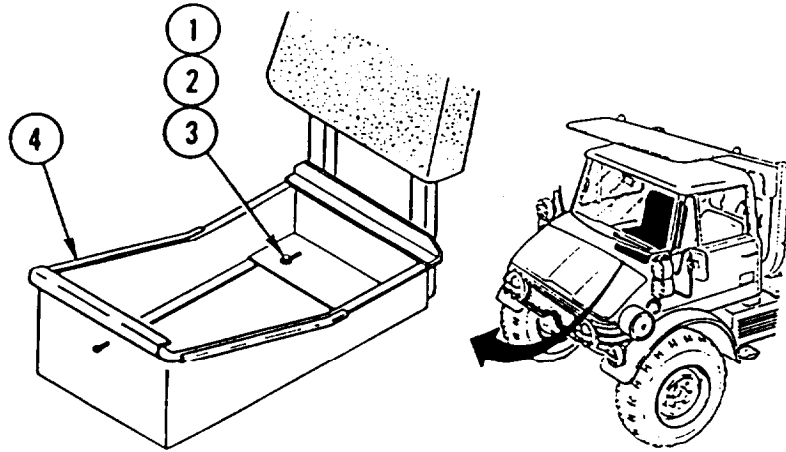

Step 1. Remove four screws (1), four washers (2), four spring tension washers (3), and passenger seat (4).

NOTE

- For steps 2 thru 49, engine must be running and clutch depressed. Failure to do so will cause erroneous results.
- Refer to wiring diagram (page 3-235) for all wiring repair steps.

Step 2. Pull and release suspension lockout control switch (5).

- If indicator light lights when control switch is pulled but goes out when control switch is released, go to step 8.
- If indicator light is not lit but pump motor is running, go to step 14.
- If indicator light is lit, pump motor is running, but lockout is not engaged, go to step 16.
- If indicator light is lit but pump motor is not running, go to step 32.
- If indicator light is not lit and pump motor is not running, go to step 3.

Table 3-5. Troubleshooting (Cont)

Malfunction	Test or Inspection	Corrective Action
-------------	--------------------	-------------------

ELECTRICAL SYSTEM (CONT)

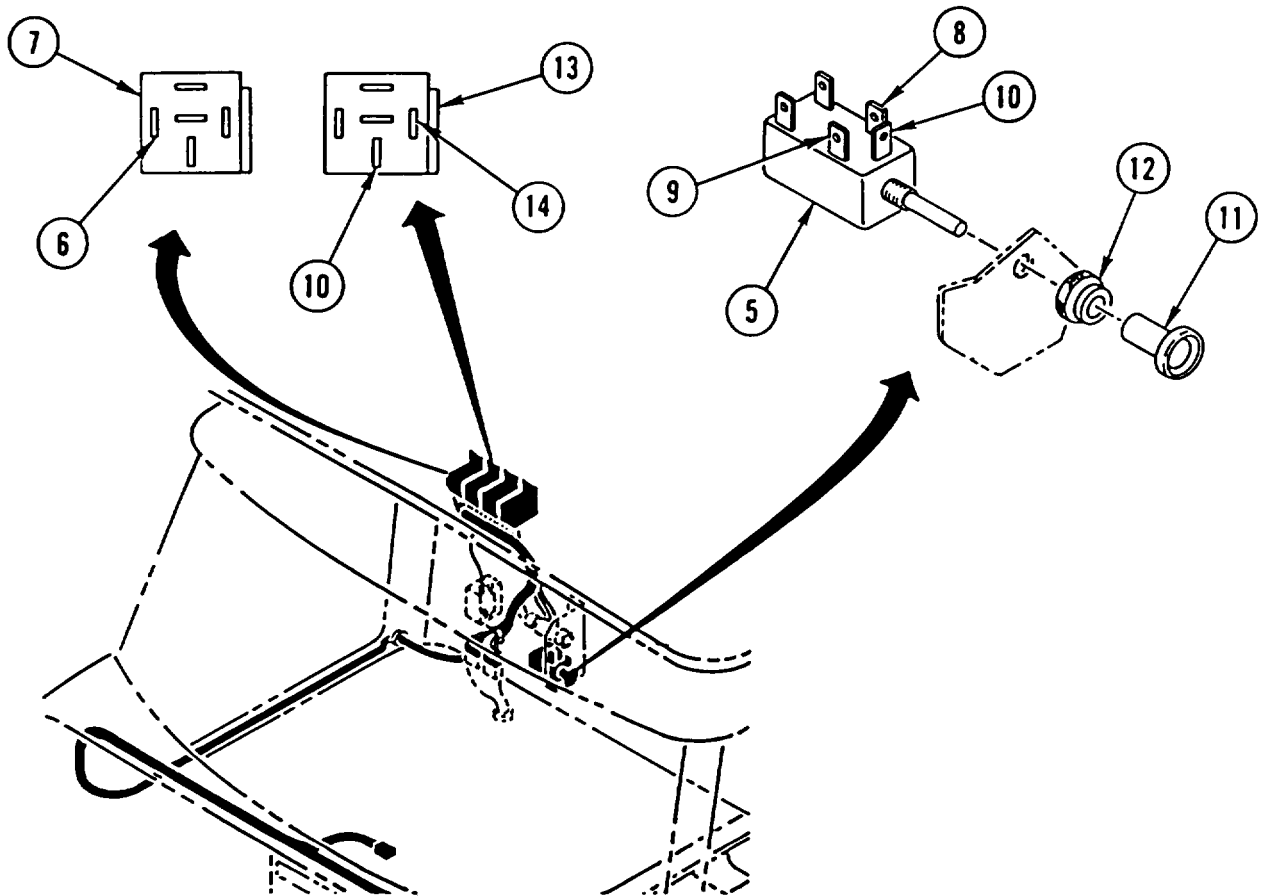

Step 3. Check for +24 VDC between wire 286 (6) and ground at D+ relay (7).

- If +24 VDC is not present, go to step 37.
- If +24 VDC is present, go to step 4.

Step 4. Check for +24 VDC between wire 712 (8) and ground at control switch (5).

- If +24 VDC is not present, go to step 21.
- If +24 VDC is present, go to step 5.

Step 5. While holding control switch (5) completely out, check for +24 VDC between wire 714 (9) and ground at control switch.

If +24 VDC is not present, replace control switch (5) by removing wire 712 (8), wire 714 (9), wire 713 (10), knob (11), nut (12), and control switch.

If +24 VDC is present, release control switch and go to step 6.

Table 3-5. Troubleshooting (Cont)

Malfunction	Test or Inspection	Corrective Action
-------------	--------------------	-------------------

ELECTRICAL SYSTEM (CONT)

Step 6. Check for +24 VDC between wire 713 (10) and ground at control switch (5).

- If +24 VDC is not present, replace control switch (5) by removing wire 712 (8), wire 714 (9), wire 713 (10), knob (11), nut (12), and control switch.
- If +24 VDC is present, go to step 7.

Step 7. Check for +24 between wire 713 (10) and ground at solenoid relay (13).

- If +24 VDC is not present, repair wiring 713 between control switch and solenoid relay.
- If +24 VDC is present, go to step 8.

Step 8. Check wire 03 (14) at solenoid relay (13) for continuity to ground.

- If open to ground, repair wiring 03 between solenoid relay and NATO slave receptacle.
- If short to ground, go to step 9.

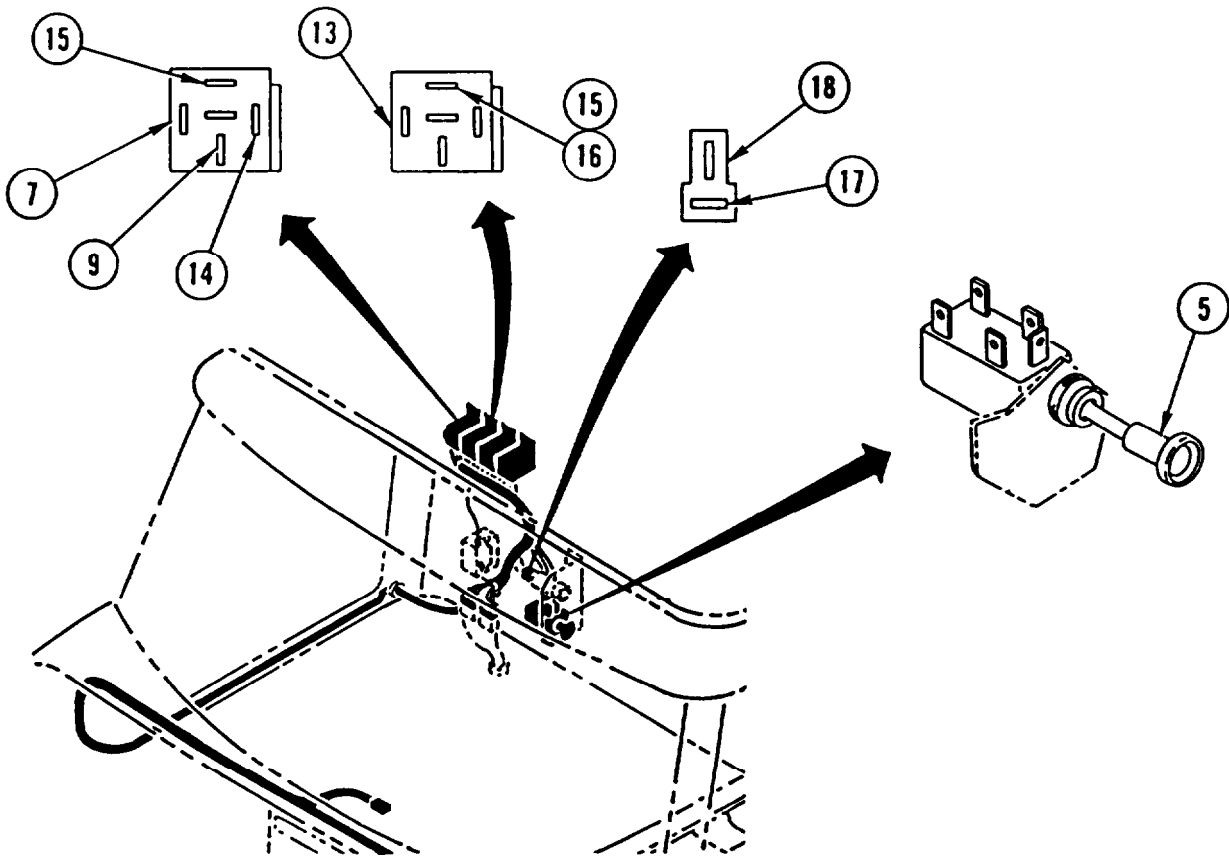

Table 3-5. Troubleshooting (Cont)

Malfunction	Test or Inspection	Corrective Action
ELECTRICAL SYSTEM (CONT)		
Step 9.	While holding control switch (5) completely out, check for +24 VDC between wire 714 (9) and ground at D+ relay (7).	<ul style="list-style-type: none"> • If +24 VDC is not present, repair wiring 714 between control switch and D+ relay. • If +24 VDC is present, go to step 10.
Step 10.	While holding control switch (5) completely out, check for +24 VDC between wire 72 (15) and ground at D+ relay (7).	<ul style="list-style-type: none"> • If +24 VDC is present, go to step 12. • If +24 VDC is not present, go to step 11.
Step 11.	Check wire 03 (14) at D+ relay (7) for continuity to ground.	<ul style="list-style-type: none"> • If open to ground, repair wiring 03 between D+ relay and ground at NATO slave receptacle. • If short to ground, replace D+ relay.
Step 12.	Check for +24 VDC between wire 72 (15) and ground at solenoid relay (13).	<ul style="list-style-type: none"> • If +24 VDC is not present, repair wiring 72 between solenoid relay and D+ relay. • If +24 VDC is present, go to step 13.
Step 13.	Check for +24 VDC between wire 721 (16) and ground at solenoid relay (13).	<ul style="list-style-type: none"> • If +24 VDC is not present, repair wiring 721 at solenoid relay. • If +24 VDC is present, go to step 14.
Step 14.	Check for +24 VDC between wire 722 (17) and ground at indicator light (18).	<ul style="list-style-type: none"> • If +24 VDC is not present, repair wiring 722 between solenoid relay and indicator light. • If +24 VDC is present, go to step 15.

Table 3-5. Troubleshooting (Cont)

Malfunction	Test or Inspection	Corrective Action
-------------	--------------------	-------------------

ELECTRICAL SYSTEM (CONT)

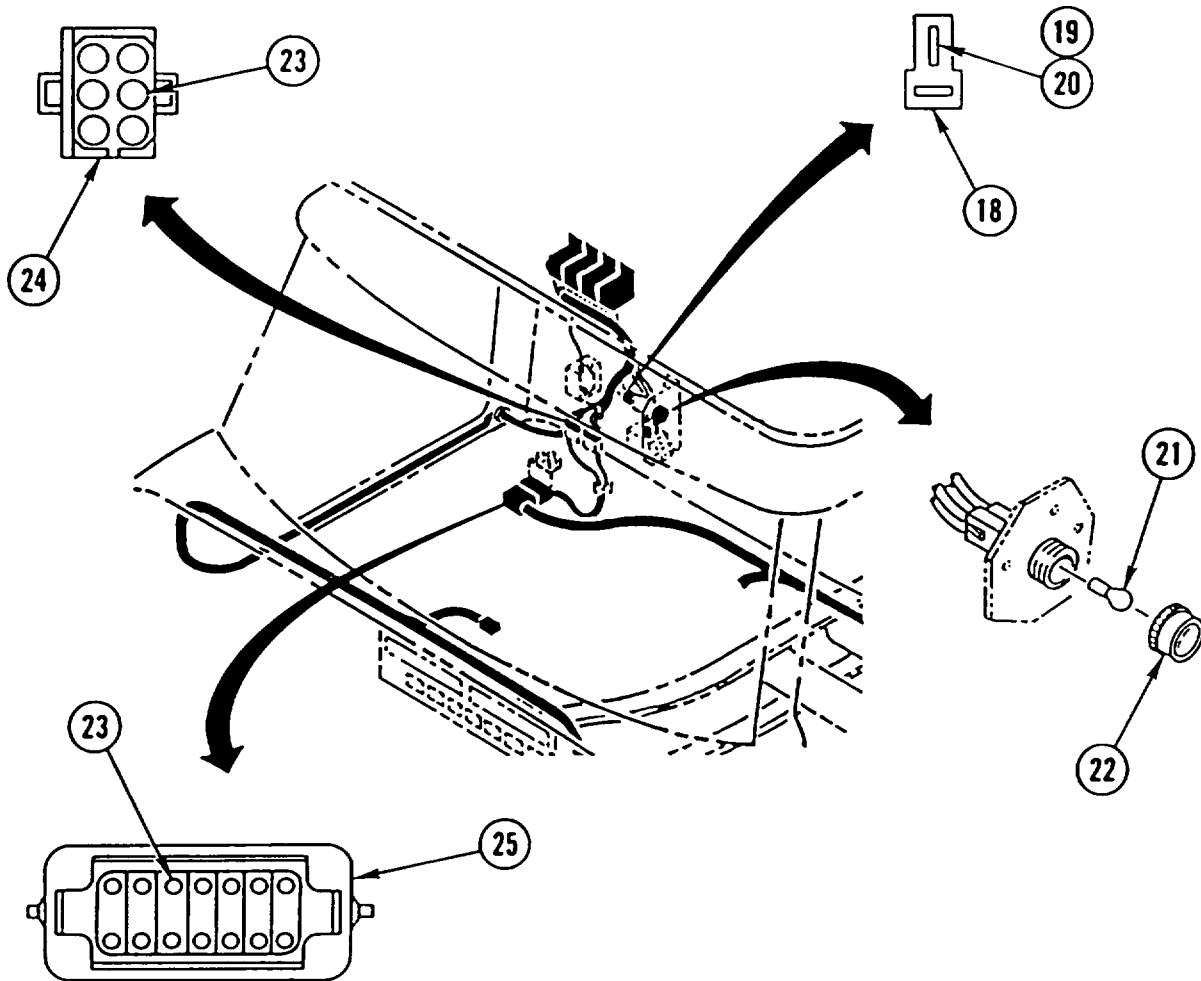

Step 15. Check wire 0 (19) and wire 01 (20) at indicator light (18) for continuity to ground.

- If open to ground, repair wiring 0 and wiring 01 between indicator light and ground.
- If short to ground, replace lamp (21) by removing nut and lens assembly (22) and lamp.

Step 16. Check for +24 VDC between wire 10 (23) and ground at connector AB (24).

- If +24 VDC is not present, repair wiring 10 between indicator light and connector AB.
- If +24 VDC is present, go to step 17.

Table 3-5. Troubleshooting (Cont)

Malfunction	Test or Inspection	Corrective Action
-------------	--------------------	-------------------

ELECTRICAL SYSTEM (CONT)

Step 17. Check for +24 VDC between wire 10 (23) and ground at pin 10 of cab floor separation point (25).

- If +24 VDC is not present, repair wiring 10 between connector AB and cab floor separation point.
- If +24 VDC is present, go to step 18.

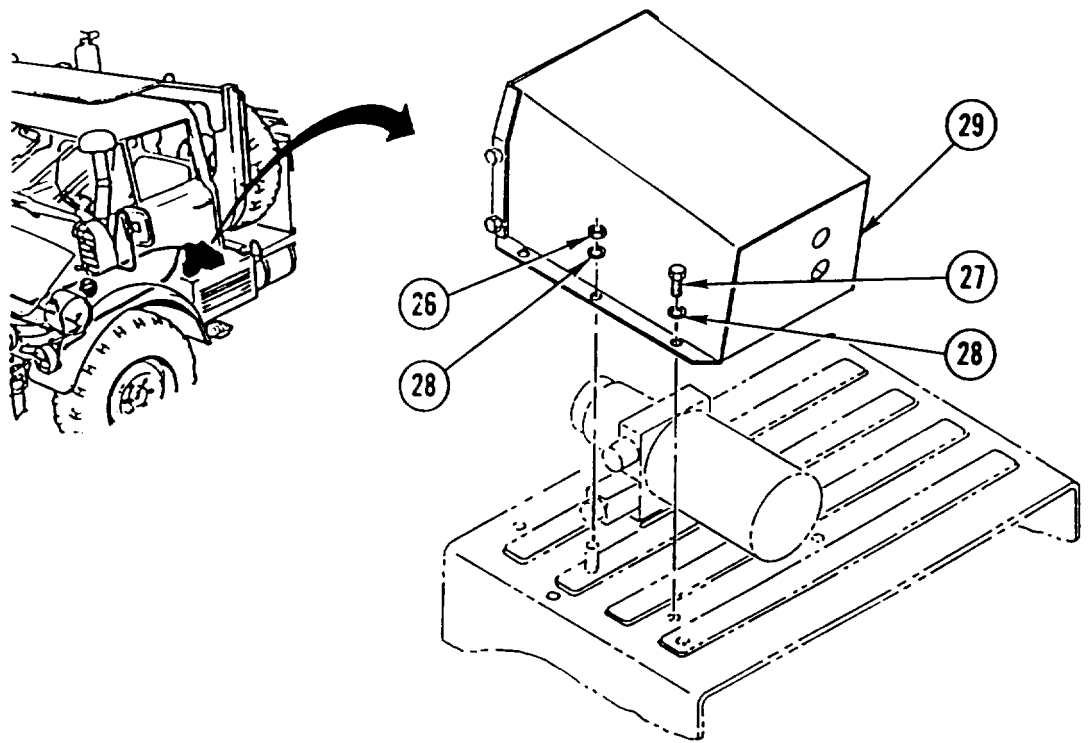

Step 18. Remove two nuts (26), four bolts (27), six washers (28), and cover (29).

Table 3-5. Troubleshooting (Cont)

Malfunction	Test or Inspection	Corrective Action
-------------	--------------------	-------------------

ELECTRICAL SYSTEM (CONT)

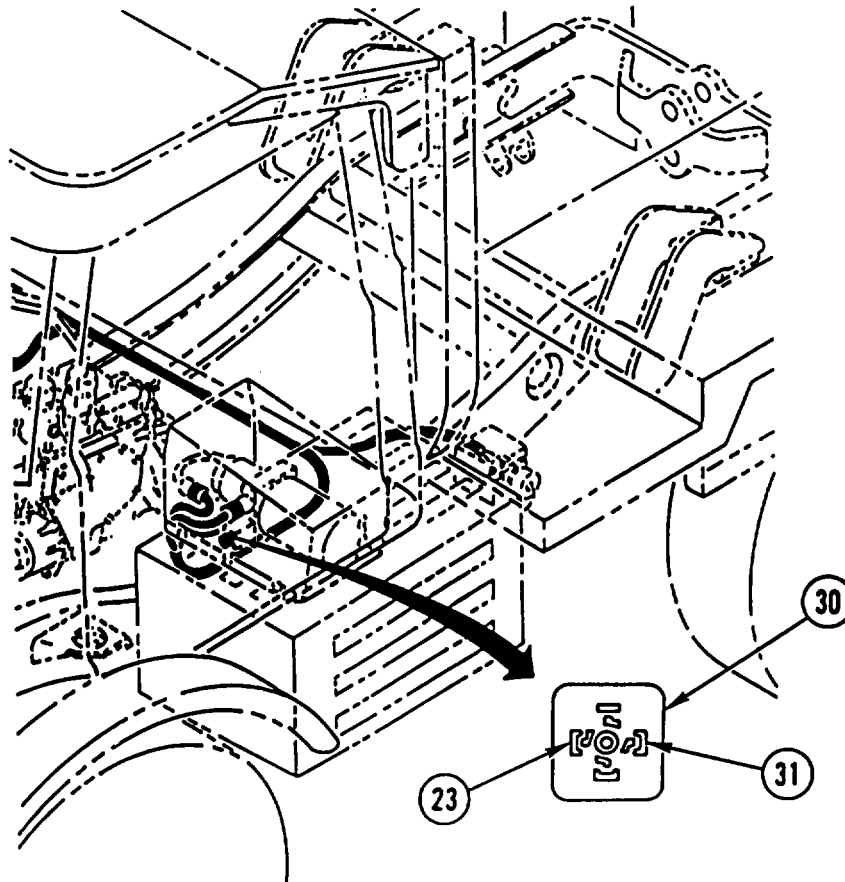

Step 19. Check for +24 VDC between wire 10 (23) and ground at pin 1 of solenoid connector (30).

- If +24 VDC is not present, repair wiring 10 between cab floor separation point and solenoid connector.
- If +24 VDC is present, go to step 20.

Step 20. Check wire 02 (31) at solenoid connector (30) for continuity to ground.

- If open to ground, repair wiring 02 between solenoid and ground at NATO slave receptacle.
- If short to ground, replace hydraulic suspension lockout pump (page 4-51 1).

Table 3-5. Troubleshooting (Cont)

Malfunction	Test or Inspection	Corrective Action
-------------	--------------------	-------------------

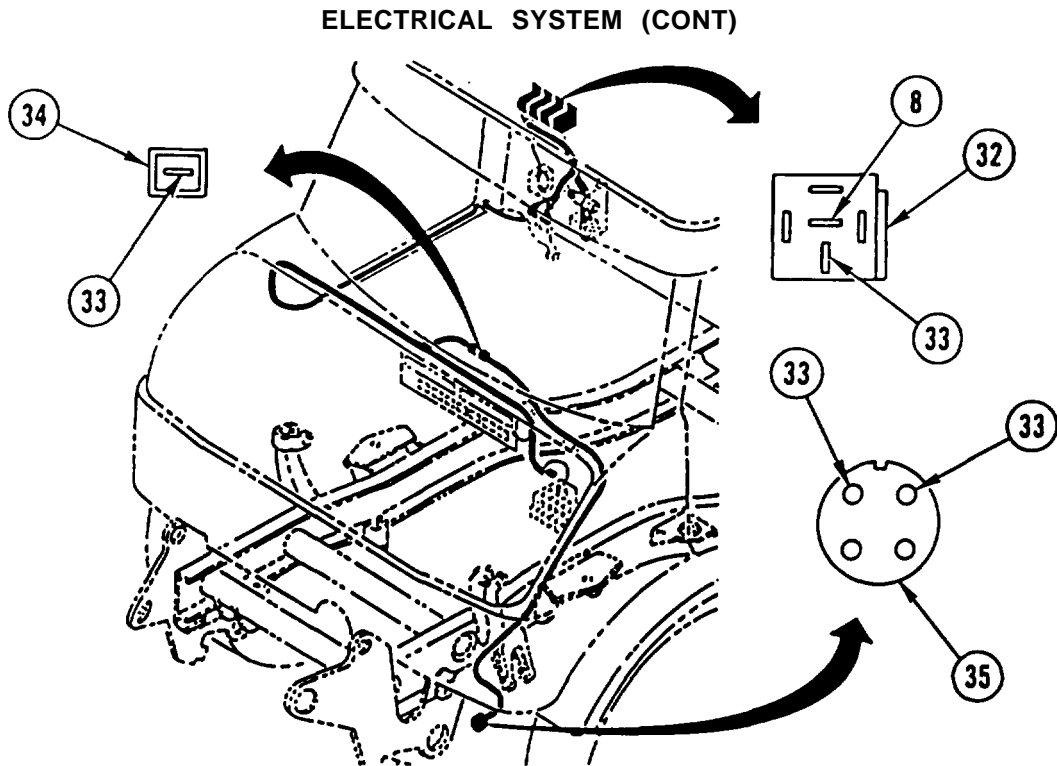

Step 21. Check for +24 VDC between wire 712 (8) and ground at fast group relay (32).

- If +24 VDC is present, repair wiring 712 between fast group relay and control switch.
- If +24 VDC is not present, go to step 22.

Step 22. Check for +24 VDC between wire 71 (33) and ground at fast group relay (32).

- If +24 VDC is present, go to step 27.
- If +24 VDC is not present, go to step 23.

Step 23. Check for +24 VDC between wire 71 (33) and ground at connector AG (34).

- If +24 VDC is present, repair wiring 71 between fast group relay and connector AG.
- If +24 VDC is not present, go to step 24.

Step 24. Check for +24 VDC between wire 71 (33) and ground at pin 4 of forklift wiring harness connector (35).

- If +24 VDC is present, repair wiring 71 between connector AG and forklift wiring harness connector.
- If +24 VDC is not present, go to step 25.

Table 3-5. Troubleshooting (Cont)

Malfunction	Test or Inspection	Corrective Action
-------------	--------------------	-------------------

ELECTRICAL SYSTEM (CONT)

Step 25. Check for +24 VDC between wire 71 (33) and ground at pin 1 of forklift wiring harness connector (35).

- If +24 VDC is present, repair wiring 71 between pin 1 and pin 4 of forklift wiring harness connector.
- If +24 VDC is not present, go to step 26.

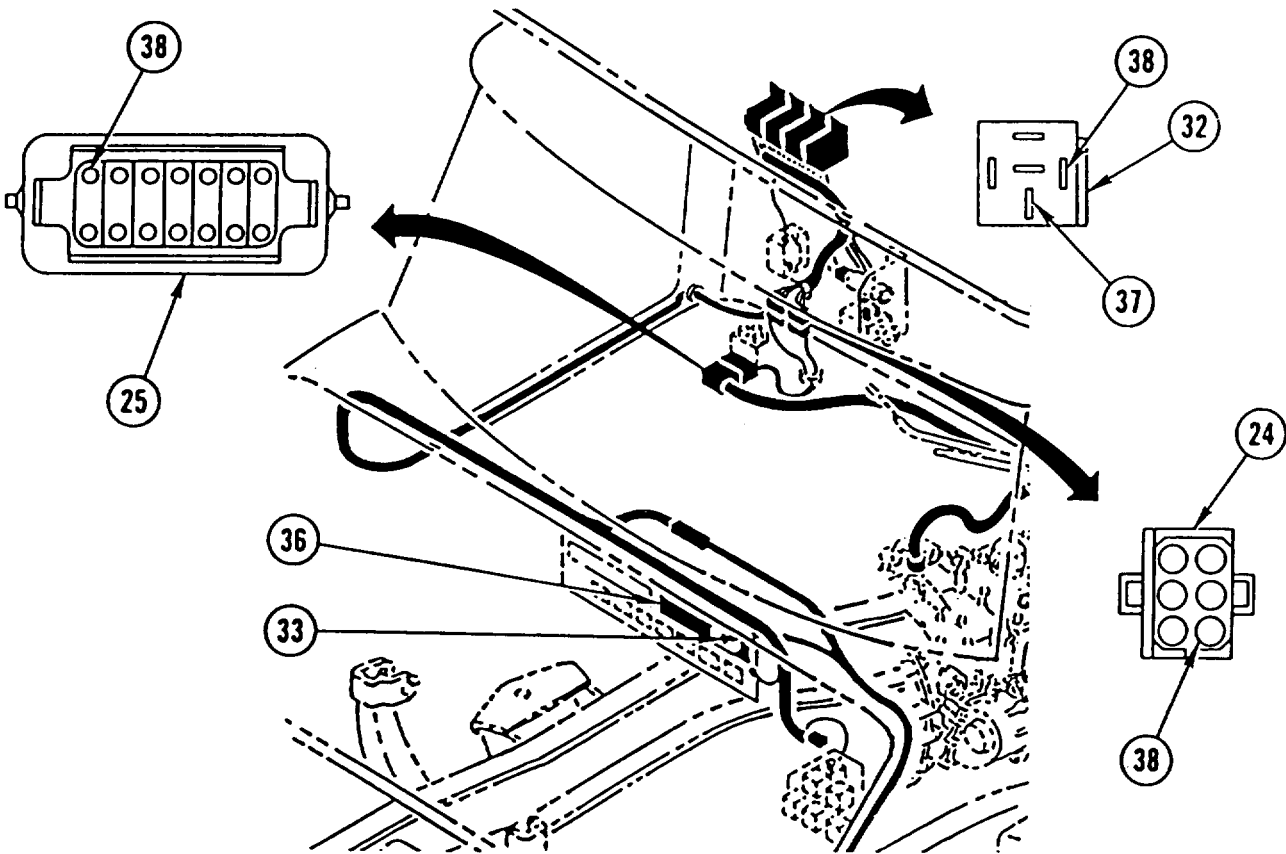

Table 3-5. Troubleshooting (Cont)

Malfunction	Test or Inspection	Corrective Action
ELECTRICAL SYSTEM (CONT)		
	Step 26. Check for +24 VDC between wire 71 (33) and ground at fuse box 1 (36).	<ul style="list-style-type: none"> • If +24 VDC is not present, replace fuse. • If +24 VDC is present, repair wiring 71 between fuse box 1 and forklift wiring harness connector.
	Step 27. Check for +24 VDC between wire 711 (37) and ground at fast group relay (32).	<ul style="list-style-type: none"> • If +24 VDC is not present, repair wiring 711 at fast group relay. • If +24 VDC is present, go to step 28.
	Step 28. Check wire 008 (38) at fast group relay (32) for continuity to ground.	<ul style="list-style-type: none"> • If open to ground, replace relay. • If short to ground, go to step 29.
	Step 29. Disconnect connector AB (24) and check wire 008 (38), on relay side of connector, for continuity to ground.	<ul style="list-style-type: none"> • If short to ground, repair wiring 008 between fast group relay and connector AB. • If open to ground, reconnect connector AB and go to step 30.
	Step 30. Disconnect cab floor separation point (25) and check wire 008 (38), on cab side of connector, for continuity to ground.	<ul style="list-style-type: none"> • If short to ground, repair wiring 008 between connector AB and cab floor separation point. • If open to ground, reconnect cab floor separation point and go to step 31.

Table 3-5. Troubleshooting (Cont)

Malfunction	Test or Inspection	Corrective Action
-------------	--------------------	-------------------

ELECTRICAL SYSTEM (CONT)

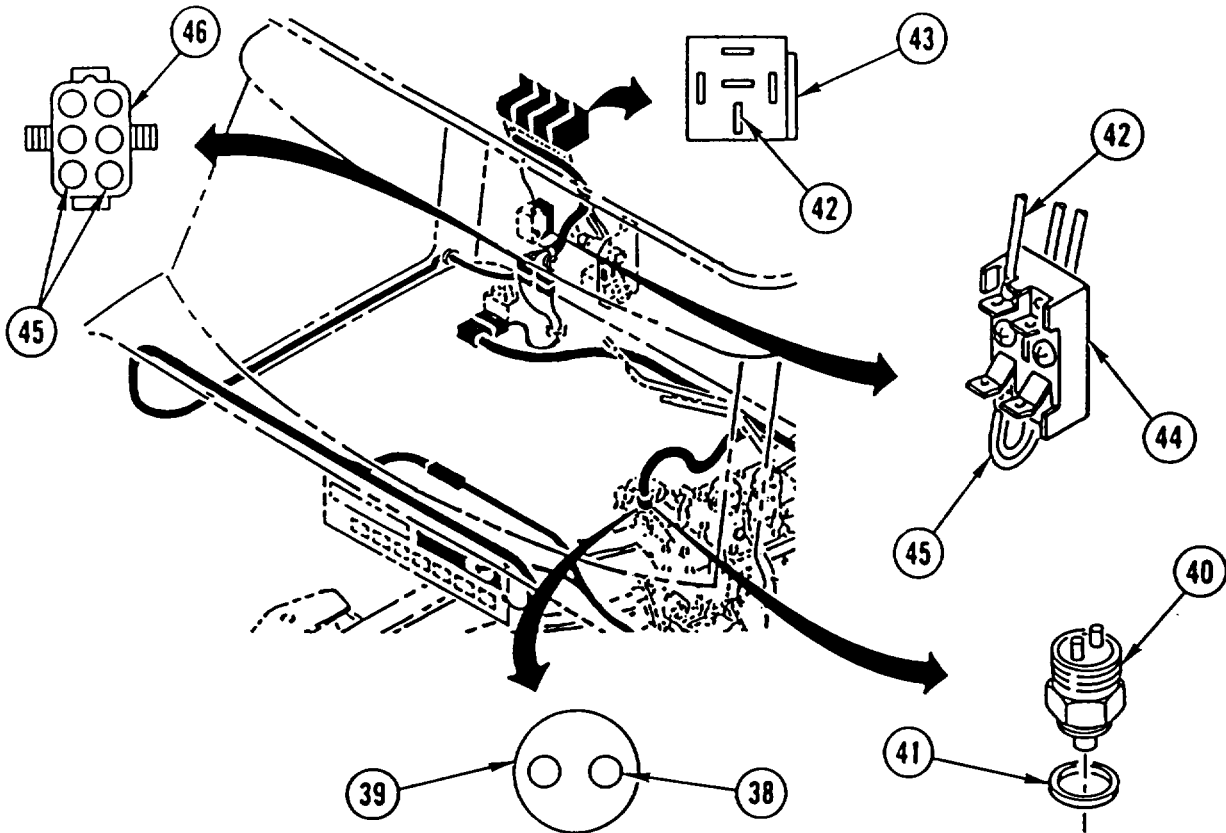

Step 31. Disconnect intermediate speed shift and indicator switch connector (39) and check wire 008 (38) for continuity to ground.

- If open to ground, replace intermediate speed shift and indicator switch (40) by removing switch and washer (41).
- If short to ground, repair wiring 008 between cab floor separation point and intermediate speed shift and indicator switch connector.

Step 32. Check for +24 VDC between wire 113 (42) and ground at motor relay (43).

- If +24 VDC is present, go to step 38.
- If +24 VDC is not present, go to step 33.

Table 3-5. Troubleshooting (Cont)

Malfunction	Test or Inspection	Corrective Action
ELECTRICAL SYSTEM (CONT)		
<p>Step 33. Check for +24 VDC between wire 113 (42) and ground at fuse box 3 (44).</p> <ul style="list-style-type: none"> ● If +24 VDC is present, repair wiring 113 between motor relay and fuse box 3. ● If +24 VDC is not present, go to step 34. 		
<p>Step 34. Check for +24 VDC between wire 2 and wire 9 (45) and ground at fuse box 3 (44).</p> <ul style="list-style-type: none"> ● If +24 VDC is present, replace 16 amp fuse. ● If +24 VDC is not present, go to step 35. 		
<p>Step 35. Check for +24 VDC between wire 2 and wire 9 (45) and ground at connector AA (46).</p> <ul style="list-style-type: none"> ● If +24 VDC is present, repair wiring 2 and wiring 9 between connector AA and fuse box 3. ● If +24 VDC is not present, go to step 36. 		

Table 3-5. Troubleshooting (Cont)

Malfunction	Test or Inspection	Corrective Action
-------------	--------------------	-------------------

ELECTRICAL SYSTEM (CONT)

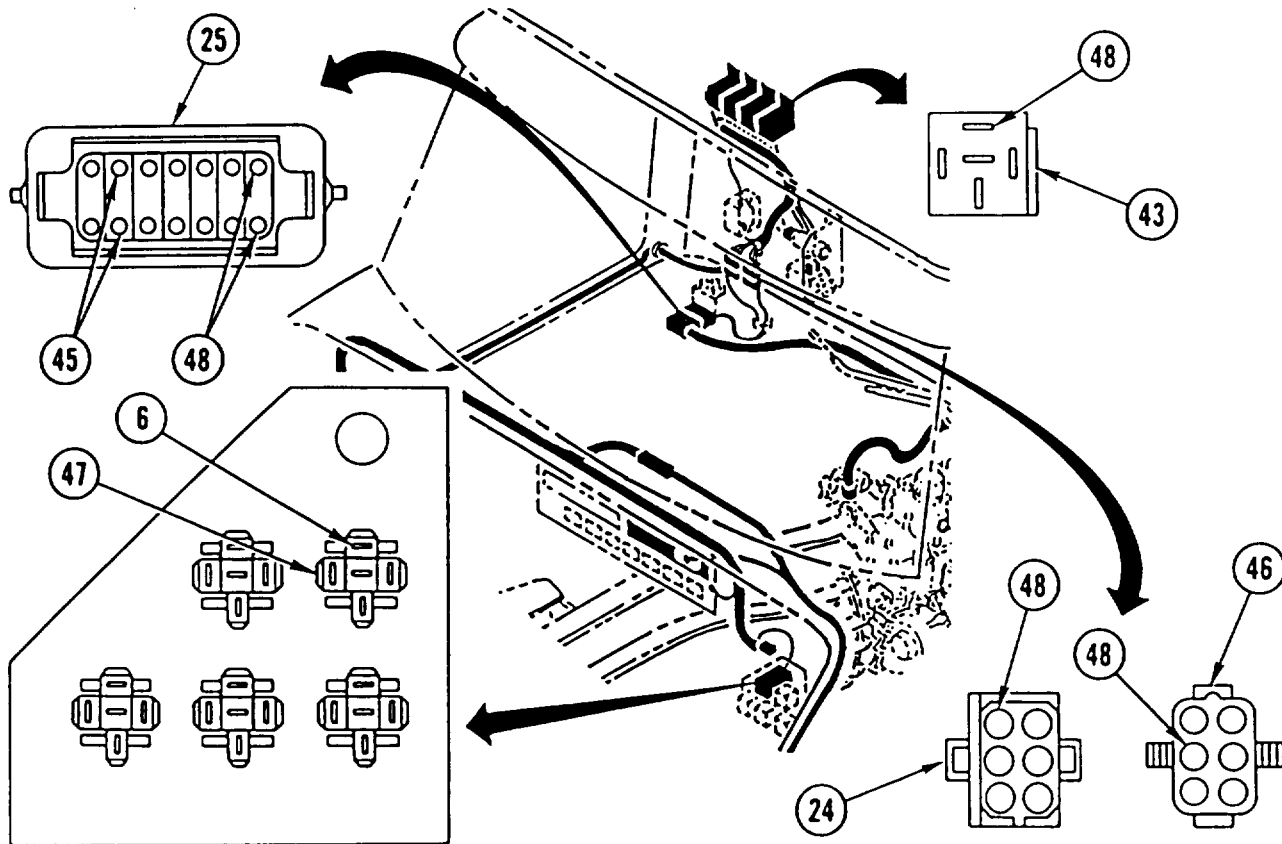

Step 36. Check for +24 VDC between wire 2 and wire 9 (45) and ground at cab floor separation point (25).

- If +24 VDC is not present, repair wiring 2 and wiring 9 between NATO slave receptacle and cab floor separation point.
- If +24 VDC is present, repair wiring 2 and wiring 9 between cab floor separation point and connector AA.

Step 37. Check for +24 VDC between wire 286 (6) and ground at relay K2 (47).

- If +24 VDC is not present, perform Malfunction 2.
- If +24 VDC is present, repair wiring 286 between D+ relay and relay K2.

Table 3-5. Troubleshooting (Cont)

Malfunction	Test or Inspection	Corrective Action
ELECTRICAL SYSTEM (CONT)		
Step 38.	Check for +24 VDC between wire 7 and wire 14 (48) and ground at motor relay (43).	<ul style="list-style-type: none"> • If +24 VDC is not present, go to step 42. • If +24 VDC is present, go to step 39.
Step 39.	Check for +24 VDC between wire 7 and wire 14 (48) and ground at connector AA (46) and connector AB (24).	<ul style="list-style-type: none"> • If +24 VDC is not present, repair wiring 7 and wiring 14 between motor relay and connector AA and connector AB. • If +24 VDC is present, go to step 40.
Step 40.	Check for +24 VDC between wire 7 and wire 14 (48) and ground at cab floor separation point (25).	<ul style="list-style-type: none"> • If +24 VDC is not present, repair wiring 7 and wiring 14 between connector AA and connector AB and cab floor separation point. • If +24 VDC is present, go to step 41.

Table 3-5. Troubleshooting (Cont)

Malfunction	Test or Inspection	Corrective Action
-------------	--------------------	-------------------

ELECTRICAL SYSTEM (CONT)

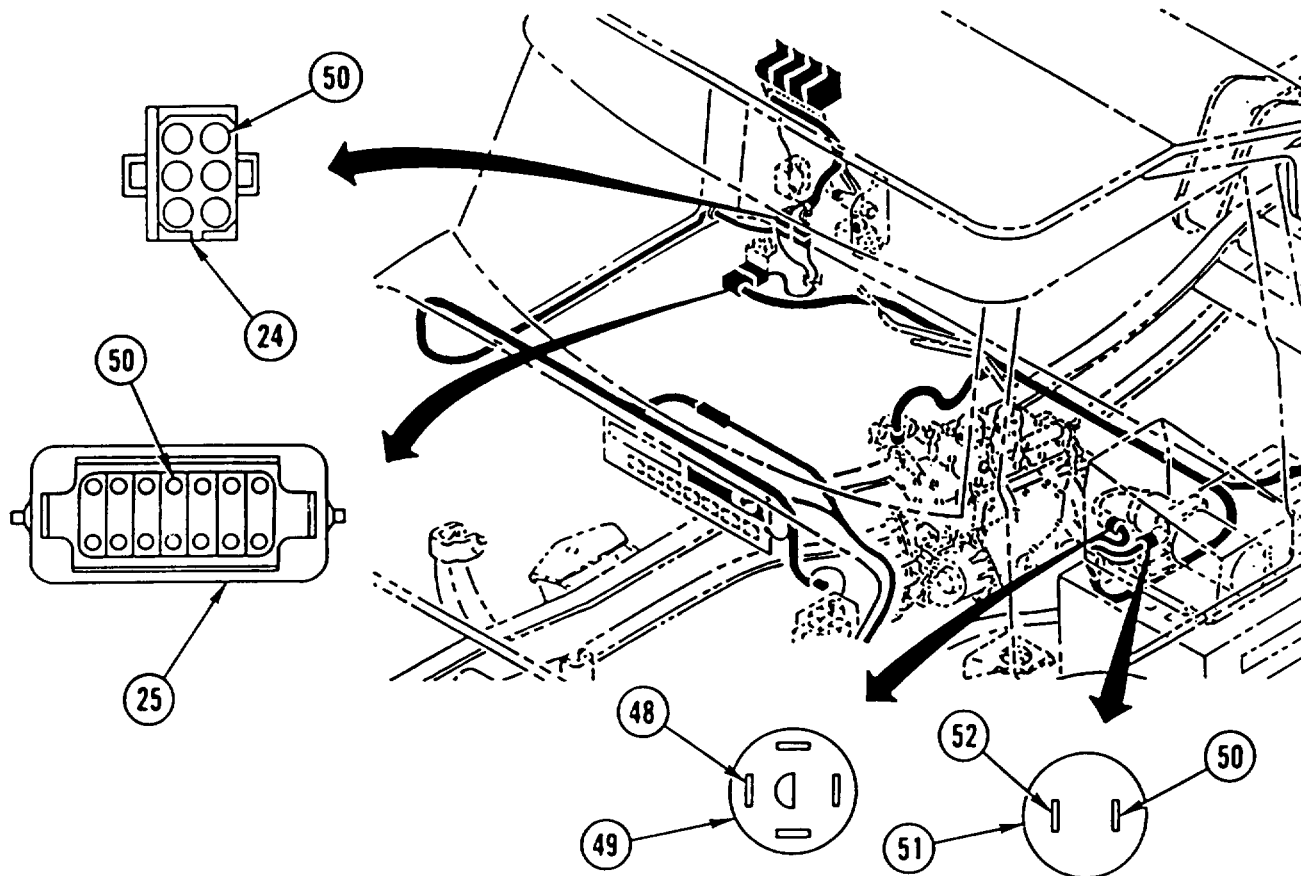

Step 41. Check for +24 VDC between wire 7 and wire 14 (48) and ground at suspension lockout pump motor (49).

- If +24 VDC is not present, repair wiring 7 and wiring 14 between cab floor separation point and pump motor.
- If +24 VDC is present, replace hydraulic suspension lockout pump (page 4-51 1).

Step 42. Check for +24 VDC between wire 11 (50) and ground at connector AB (24).

- If +24 VDC is not present, repair wiring 11 between D+ relay and connector AB.
- If +24 VDC is present, go to step 43

Table 3-5. Troubleshooting (Cont)

Malfunction	Test or Inspection	Corrective Action
ELECTRICAL SYSTEM (CONT)		
Step 43.	Check for +24 VDC between wire 11 (50) and ground at cab floor separation point (25).	<ul style="list-style-type: none"> • If +24 VDC is not present, repair wiring 11 between connector AB and cab floor separation point. • If +24 VDC is present, go to step 44.
Step 44.	Check for +24 VDC between wire 11 (50) and ground at hydraulic switch (51),	<ul style="list-style-type: none"> • If +24 VDC is not present, repair wiring 11 between cab floor separation point and hydraulic switch. • If +24 VDC is present, go to step 45.
Step 45.	Check for +24 VDC between wire 4 (52) and ground at hydraulic switch (51).	<ul style="list-style-type: none"> • If +24 VDC is not present, replace hydraulic suspension lockout pump (page 4-51 1). • If +24 VDC is present, go to step 46.

Table 3-5. Troubleshooting (Cont)

Malfunction	Test or Inspection	Corrective Action
-------------	--------------------	-------------------

ELECTRICAL SYSTEM (CONT)

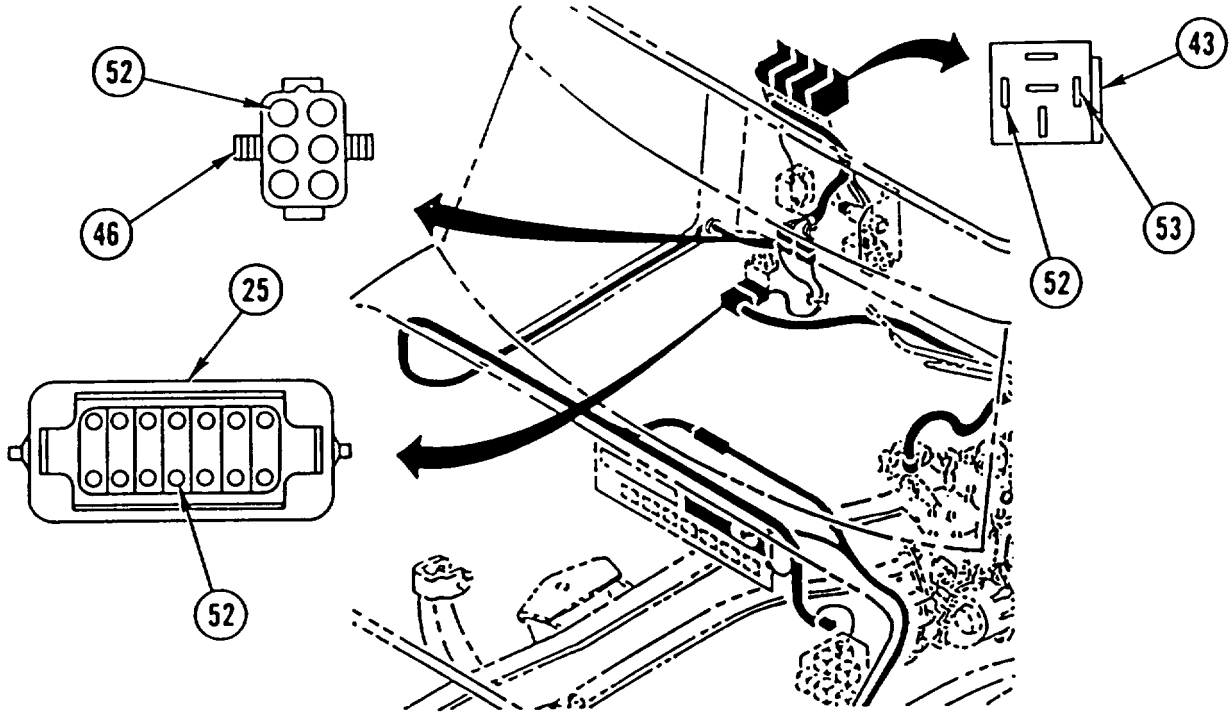

- Step 46. Check for +24 VDC between wire 4 (52) and ground at cab floor separation point (25).
- If +24 VDC is not present, repair wiring 4 between hydraulic switch and cab floor separation point.
 - If +24 VDC is present, go to step 47.
- Step 47. Check for +24 VDC between wire 4 (52) and ground at connector AA (46).
- If +24 VDC is not present, repair wiring 4 between cab floor separation point and connector AA.
 - If +24 VDC is present, go to step 48.
- Step 48. Check for +24 VDC between wire 4 (52) and ground at motor relay (43).
- If +24 VDC is not present, repair wiring 4 between connector AA and motor relay.
 - If +24 VDC is present, go to step 49.
- Step 49. Check wire 01 (53) at motor relay (43) for continuity to ground.
- If short to ground, replace motor relay.
 - If open to ground, repair wiring 01 between motor relay and NATO slave receptacle.

Table 3-5. Troubleshooting (Cont)

Malfunction	Test or Inspection	Corrective Action
-------------	--------------------	-------------------

ELECTRIAL SYSTEM (CONT)

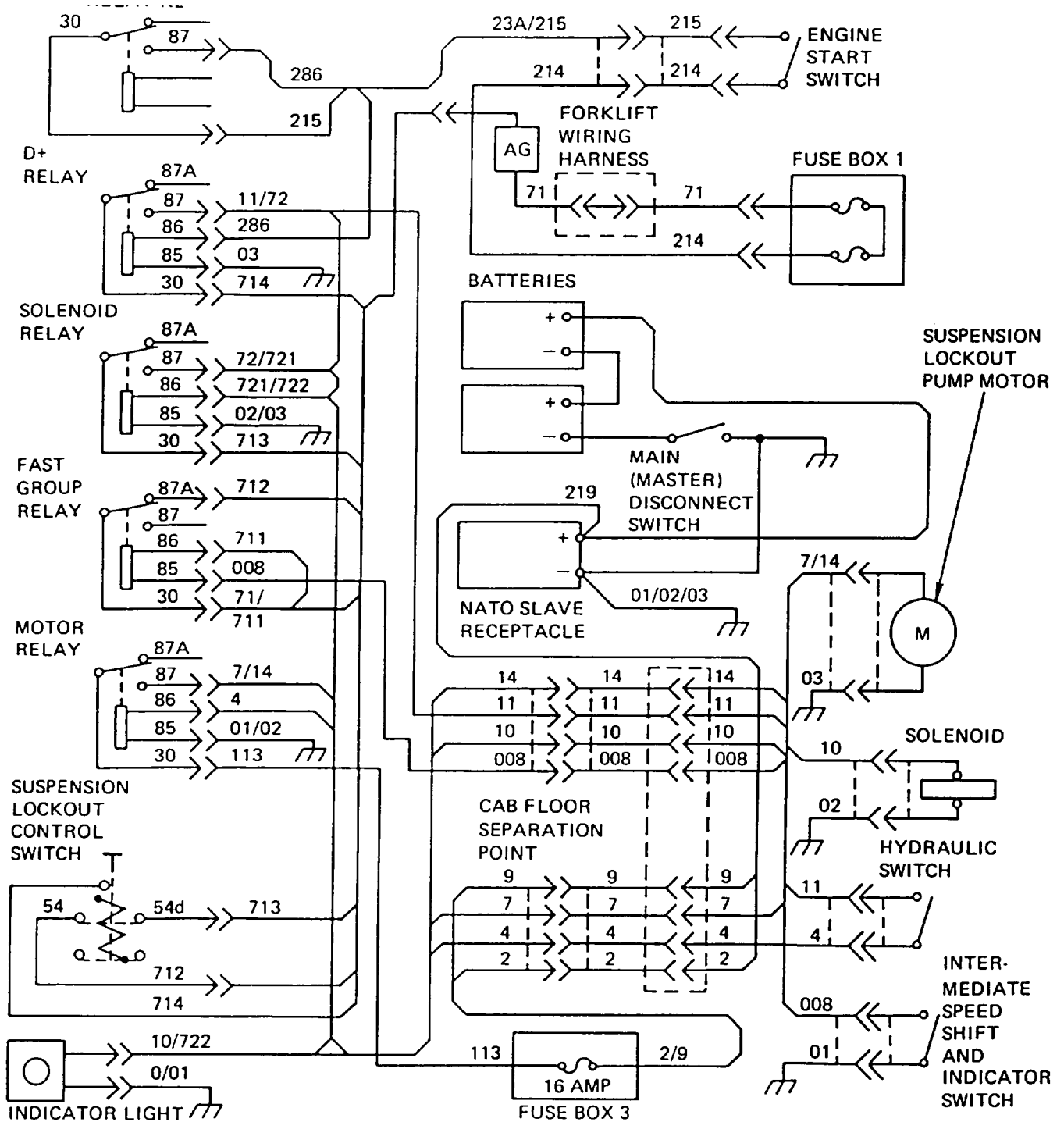

Table 3-5. Troubleshooting (Cont)

Malfunction

Test or Inspection

Corrective Action

ELECTRICAL SYSTEM (CONT)

73. HYDRAULIC SUSPENSION LOCKOUT WILL NOT ENGAGE (HMMH) (REG. NO. UC053E THRU UC053K).

NOTE

- Electrical quick disconnect for forklift must be connected to vehicle,
- Refer to wiring diagram (page 3-253) for all wiring repair steps.

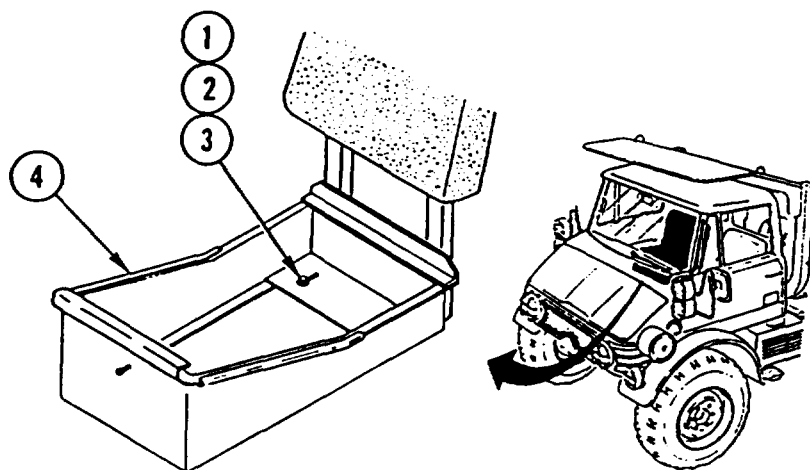

Step 1. Remove four screws (1), four washers (2), four spring tension washers (3), and passenger seat (4).

Table 3-5. Troubleshooting (Cont)

Malfunction	Test or Inspection	Corrective Action
-------------	--------------------	-------------------

ELECTRICAL SYSTEM (CONT)

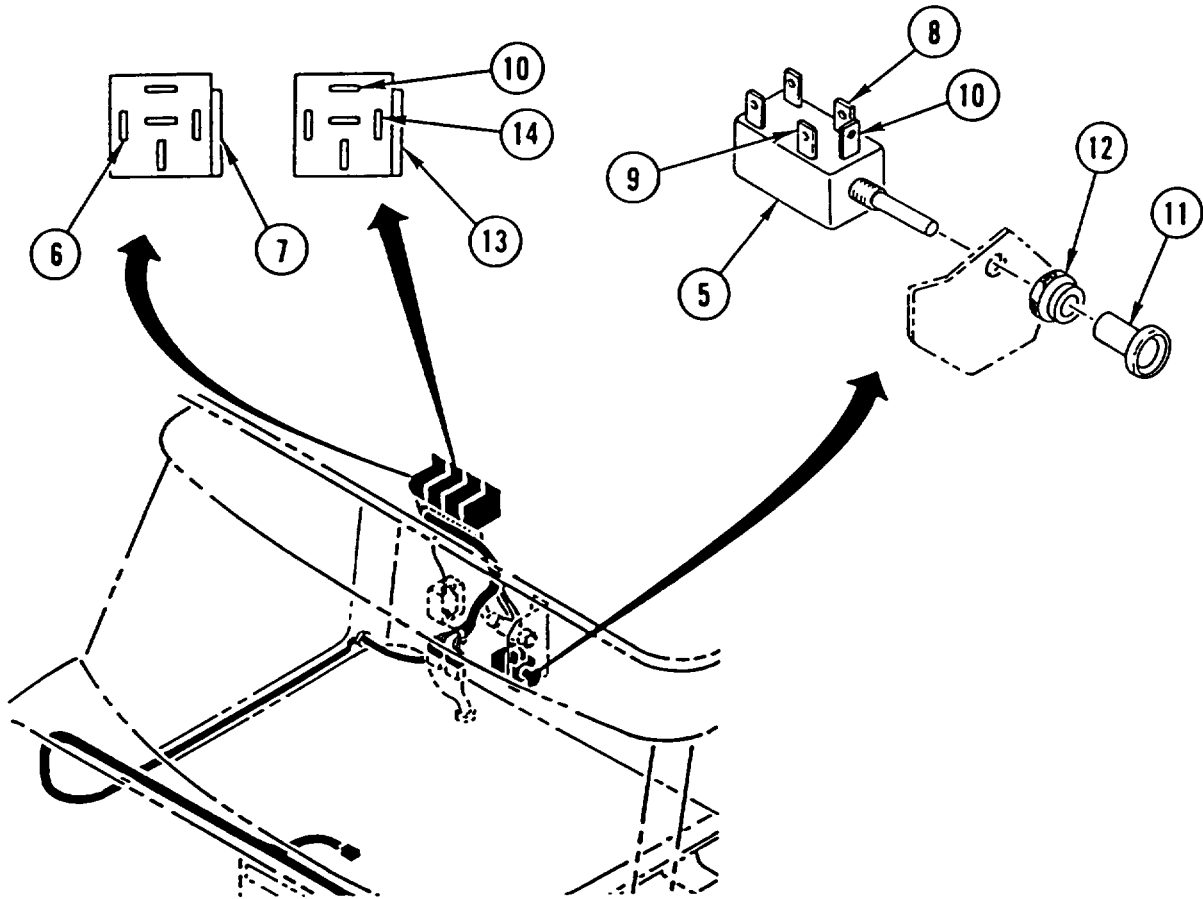

NOTE

For steps 2 thru 48, engine must be running and clutch depressed. Failure to do so will cause erroneous results.

Step 2. Pull and release suspension lockout control switch (5).

- If indicator light lights when control switch is pulled but goes out when control switch is released, go to step 8.
- If indicator light is not lit but pump motor is running, go to step 14.
- If indicator light is lit, pump motor is running, but lockout is not engaged, go to step 17.
- If indicator light is lit but pump motor is not running, go to step 30.
- If indicator light is not lit and pump motor is not running, go to step 3.

Table 3-5. Troubleshooting (Cont)

Malfunction	Test or Inspection	Corrective Action
ELECTRICAL SYSTEM (CONT)		
Step 3.	Check for +24 VDC between wire (6) and ground at D+ relay (7).	<ul style="list-style-type: none"> ● If +24 VDC is not present, go to step 35. ● If +24 VDC is present, go to step 4.
Step 4.	Check for +24 VDC between wire (8) and ground at control switch (5).	<ul style="list-style-type: none"> ● If +24 VDC is not present, go to step 22. ● If +24 VDC is present, go to step 5.
Step 5.	While holding control switch (5) completely out, check for +24 VDC between wire (9) and ground at control switch.	<ul style="list-style-type: none"> ● If +24 VDC is not present, replace control switch (5) by removing wire (8), wire (9), wire (10), knob (11), nut (12), and control switch. ● If +24 VDC is present, release control switch and go to step 6.
Step 6.	Check for +24 VDC between wire (10) and ground at control switch (5).	<ul style="list-style-type: none"> ● If +24 VDC is not present, replace control switch (5) by removing wire (8), wire (9), wire (10), knob (11), nut (12), and control switch. ● If +24 VDC is present, go to step 7.
Step 7.	Check for +24 VDC between wire (10) and ground at solenoid relay (13).	<ul style="list-style-type: none"> ● If +24 VDC is not present, repair wiring (10) between control switch and solenoid relay. ● If +24 VDC is present, go to step 8.
Step 8.	Check wire (14) at solenoid relay (13) for continuity to ground.	<ul style="list-style-type: none"> ● If open to ground, go to step 11. ● If short to ground, go to step 9.

Table 3-5. Troubleshooting (Cont)

Malfunction	Test or Inspection	Corrective Action
-------------	--------------------	-------------------

ELECTRICAL SYSTEM (CONT)

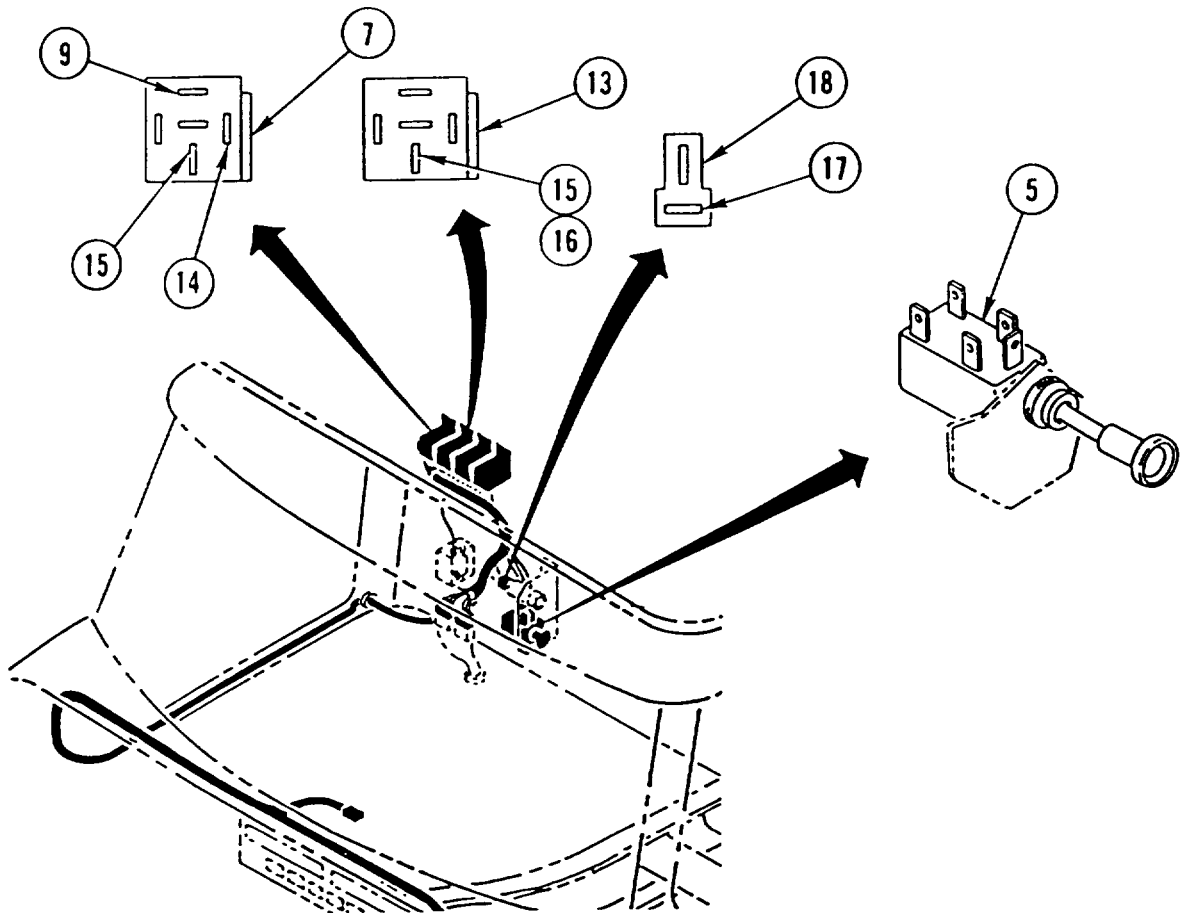

Step 9. While holding control switch (5) completely out, check for +24 VDC between wire (9) and ground at D+ relay (7).

- If +24 VDC is not present, repair wiring (9) between control switch and D+ relay.
- If +24 VDC is present, go to step 10.

Step 10. While holding control switch (5) completely out, check for +24 VDC between wire (15) and ground at D+ relay (7).

- If +24 VDC is present, go to step 12.
- if +24 VDC is not present, go to step 11.

Table 3-5. Troubleshooting (Cont)

Malfunction	Test or Inspection	Corrective Action
ELECTRICAL SYSTEM (CONT)		
	Step 11. Check wire (14) at D+ relay (7) for continuity to ground.	<ul style="list-style-type: none"> ● If short to ground, replace D+ relay. ● If open to ground, repair wiring (14) between D+ relay and ground at fuse box 1.
	Step 12. Check for +24 VDC between wire (15) and ground at solenoid relay (13).	<ul style="list-style-type: none"> ● If +24 VDC is not present, repair wiring (15) between solenoid relay and D+ relay. ● If +24 VDC is present, go to step 13.
	Step 13. Check for +24 VDC between wire (16) and ground at solenoid relay (13).	<ul style="list-style-type: none"> ● If +24 VDC is not present, repair wiring (16) at solenoid relay. ● If +24 VDC is present, go to step 14.
	Step 14. Check for +24 VDC between wire (17) and ground at indicator light (18).	<ul style="list-style-type: none"> ● If +24 VDC is not present, repair wiring (17) between solenoid relay and indicator light. ● If +24 VDC is present, go to step 15.

Table 3-5. Troubleshooting (Cont)

Malfunction	Test or Inspection	Corrective Action
-------------	--------------------	-------------------

ELECTRICAL SYSTEM (CONT)

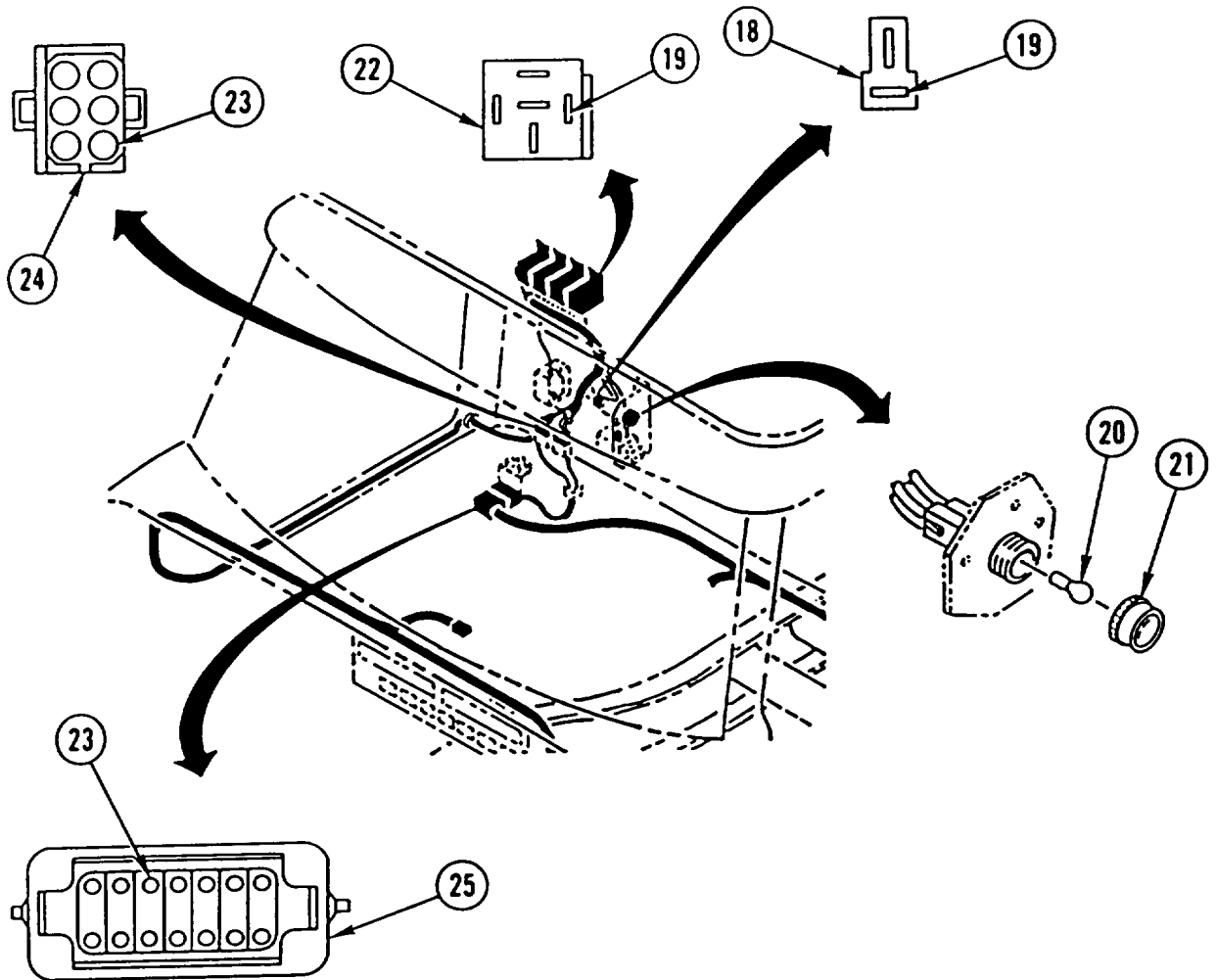

Table 3-5. Troubleshooting (Cont)

Malfunction	Test or Inspection	Corrective Action
ELECTRICAL SYSTEM (CONT)		
Step 15.	Check wire (19) at indicator light (18) for continuity to ground.	<ul style="list-style-type: none"> • If short to ground, replace lamp (20) by removing nut and lens assembly (21) and lamp. • if open to ground, go to step 16.
Step 16.	Check wire (19) at motor relay (22) for continuity to ground.	<ul style="list-style-type: none"> • If open to ground, go to step 48. • If short to ground, repair wiring (19) between motor relay and indicator light.
Step 17.	Check for +24 VDC between wire (23) and ground at connector AB (24).	<ul style="list-style-type: none"> • If +24 VDC is not present, repair wiring (23) between indicator light and connector AB. • If +24 VDC is present, go to step 18.
Step 18.	Check for +24 VDC between wire (23) and ground at pin 10 of cab floor separation point (25).	<ul style="list-style-type: none"> • If +24 VDC is not present, repair wiring (23) between connector AB and cab floor separation point. • If +24 VDC is present, go to step 19.

Table 3-5. Troubleshooting (Cont)

Malfunction	Test or Inspection	Corrective Action
-------------	--------------------	-------------------

ELECTRICAL SYSTEM (CONT)

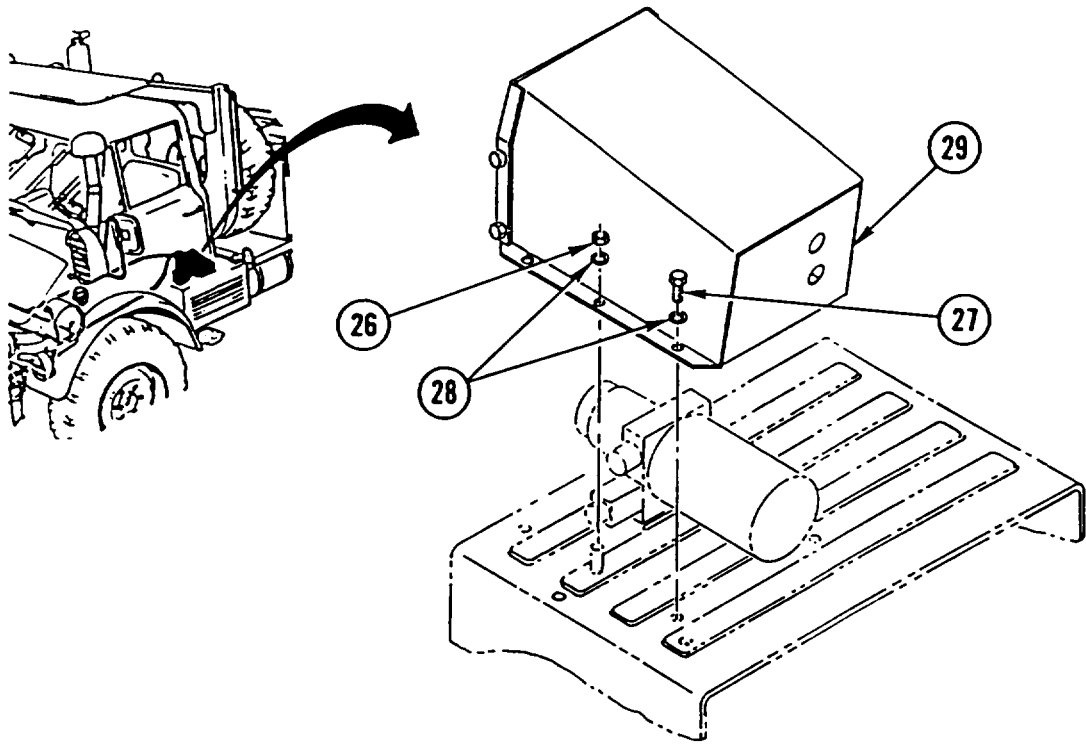

Step 19. Remove two nuts (26), four bolts (27), six washers (28), and cover (29).

Table 3-5. Troubleshooting (Cont)

Malfunction	Test or Inspection	Corrective Action
-------------	--------------------	-------------------

ELECTRICAL SYSTEM (CONT)

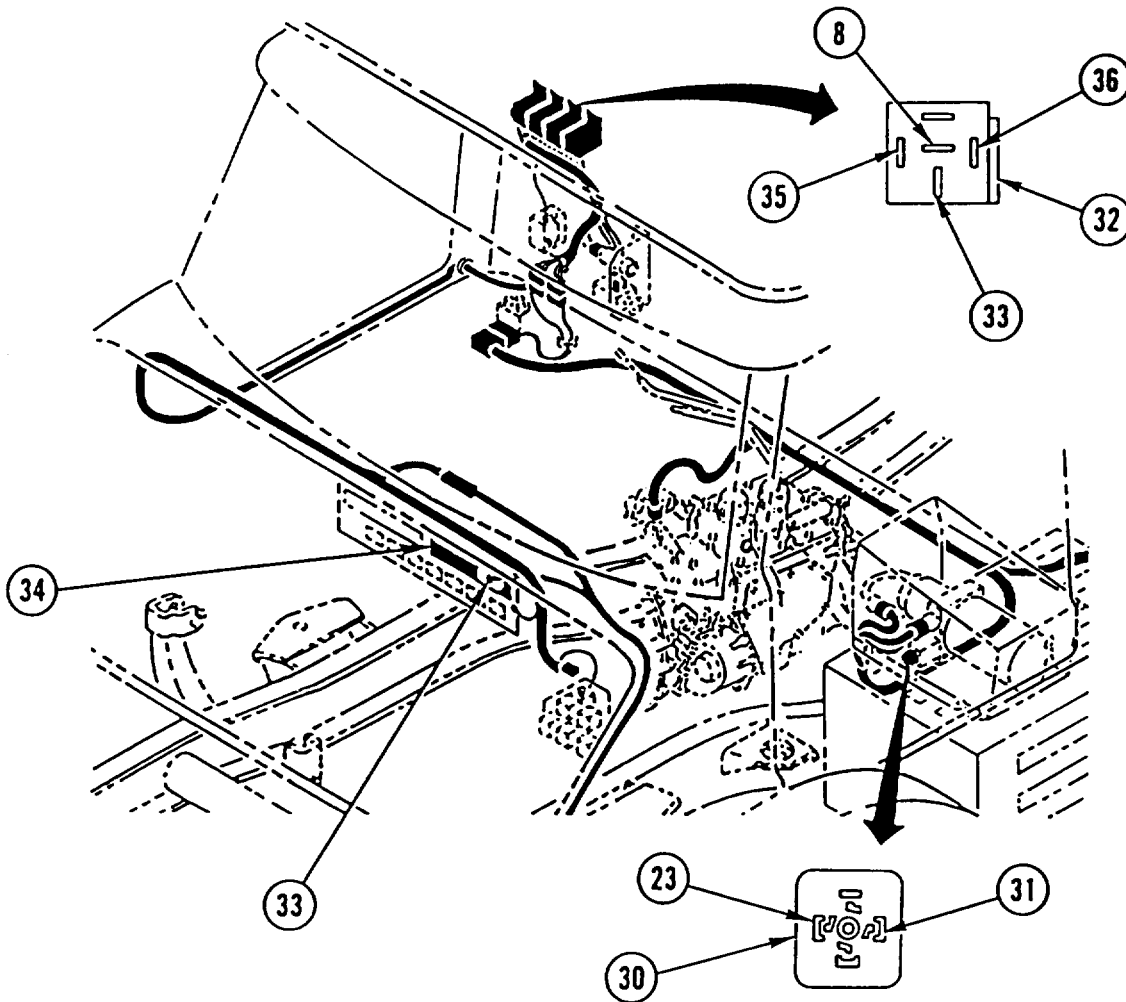

Table 3-5. Troubleshooting (Cont)

Malfunction	Test or Inspection	Corrective Action
ELECTRICAL SYSTEM (CONT)		
Step 20. Check for +24 VDC between wire (23) and ground at pin 1 of solenoid connector (30).	<ul style="list-style-type: none"> • If +24 VDC is not present, repair wiring (23) between cab floor separation point and solenoid "connector. • If +24 VDC is present, go to step 21. 	
Step 21. Check wire (31) at solenoid connector (30) for continuity to ground.	<ul style="list-style-type: none"> • If short to ground, replace hydraulic suspension lockout pump (page 4-511). • If open to ground, repair wiring (31) between solenoid and ground at NATO slave receptacle. 	
Step 22. Check for +24 VDC between wire (8) and ground at fast group relay (32).	<ul style="list-style-type: none"> • If +24 VDC is present, repair wiring (8) between fast group relay and control switch. • If +24 VDC is not present, go to step 23. 	
Step 23. Check for +24 VDC between wire (33) and ground at fast group relay (32).	<ul style="list-style-type: none"> • If +24 VDC is present, go to step 25. • If +24 VDC is not present, go to step 24. 	
Step 24. Check for +24 VDC between wire (33) and ground at fuse box 1 (34).	<ul style="list-style-type: none"> • If +24 VDC is not present, replace fuse. • If +24 VDC is present, repair wiring (33) between fast group relay and fuse box 1. 	
Step 25. Check for +24 VDC between wire (35) and ground at fast group relay (32).	<ul style="list-style-type: none"> • If +24 VDC is not present, repair wiring (35) at fast group relay. • If +24 VDC is present, go to step 26. 	
Step 26. Check wire (36) at fast group relay (32) for continuity to ground.	<ul style="list-style-type: none"> • If short to ground, go to step 27. • If open to ground, replace relay. 	

Table 3-5. Troubleshooting (Cont)

Malfunction

Test or Inspection

Corrective Action

Electrical SYSTEM (CONT)

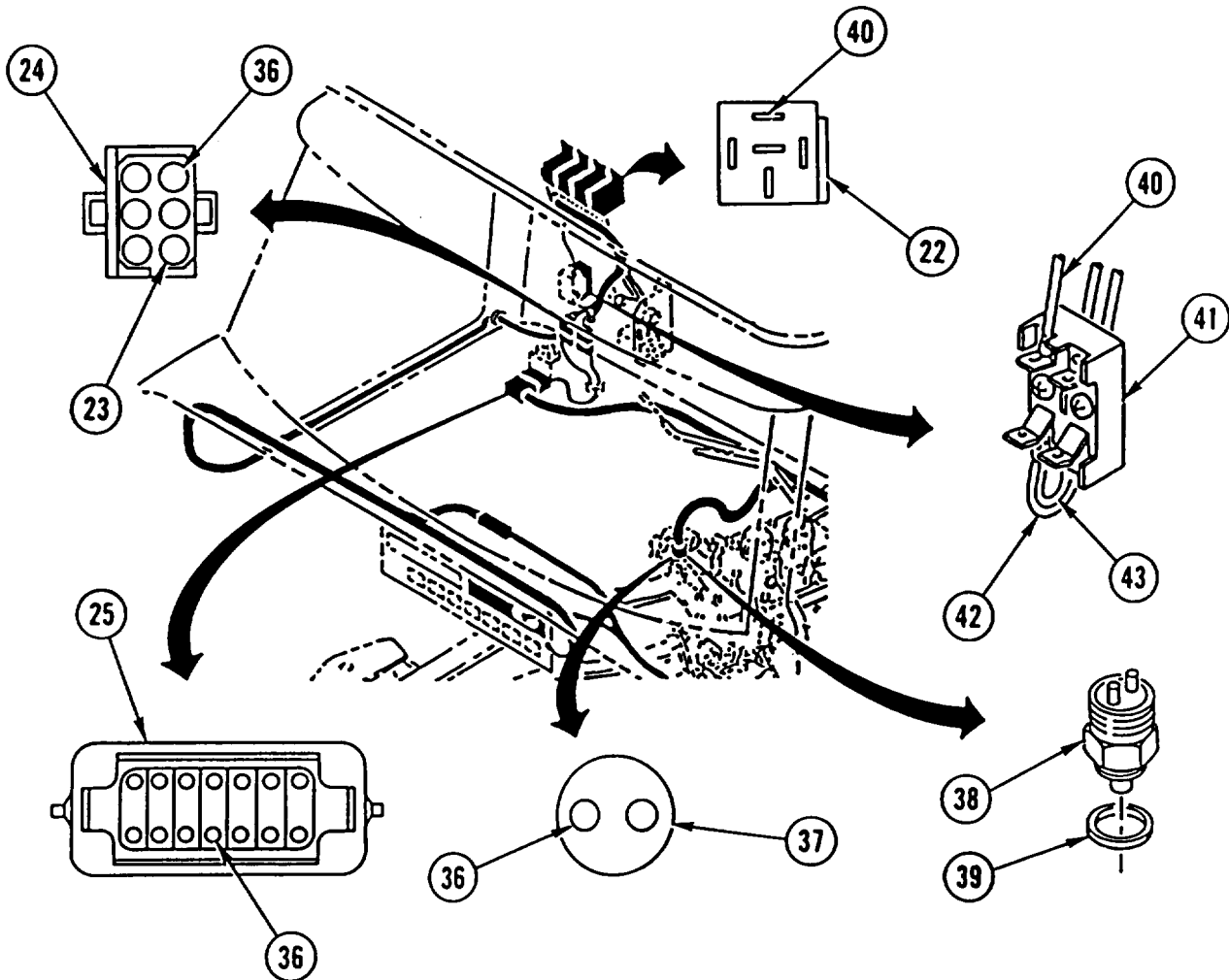

Table 3-5. Troubleshooting (Cont)

Malfunction	Test or Inspection	Corrective Action
ELECTRICAL SYSTEM (CONT)		
Step 27.	Disconnect connector AB (24) and check wire (36), on relay side of connector, for continuity to ground.	<ul style="list-style-type: none"> • If short to ground, repair wiring (36) between fast group relay and connector AB. • If open to ground, reconnect connector AB and go to step 28.
Step 28.	Disconnect cab floor separation point (25) and check wire (36), on cab side of connector, for continuity to ground.	<ul style="list-style-type: none"> • If short to ground, repair wiring (36) between connector AB and cab floor separation point. • If open to ground, reconnect cab floor separation point and go to step 29.
Step 29.	Disconnect intermediate speed shift and indicator switch connector (37) and check wire (36) for continuity to ground.	<ul style="list-style-type: none"> • If open to ground, replace intermediate speed shift and indicator switch (38) by removing switch and washer (39). • If short to ground, repair wiring (36) between cab floor separation point and intermediate speed shift and indicator switch connector.
Step 30.	Check for +24 VDC between wire (40) and ground at motor relay (22).	<ul style="list-style-type: none"> • If +24 VDC is present, go to step 37. • If +24 VDC is not present, go to step 31.
Step 31.	Check for +24 VDC between wire (40) and ground at fuse box 3 (41).	<ul style="list-style-type: none"> • If +24 VDC is present, repair wiring (40) between motor relay and fuse box 3. • If +24 VDC is not present, go to step 32.
Step 32.	Check for +24 VDC between wire (42) and wire (43) and ground at fuse box 3 (41).	<ul style="list-style-type: none"> • If +24 VDC is present, replace 16 amp fuse. • If +24 VDC is not present, go to step 33.

Table 3-5. Troubleshooting (Cont)

Malfunction	Test or Inspection	Corrective Action
-------------	--------------------	-------------------

Electrical SYSTEM (CONT)

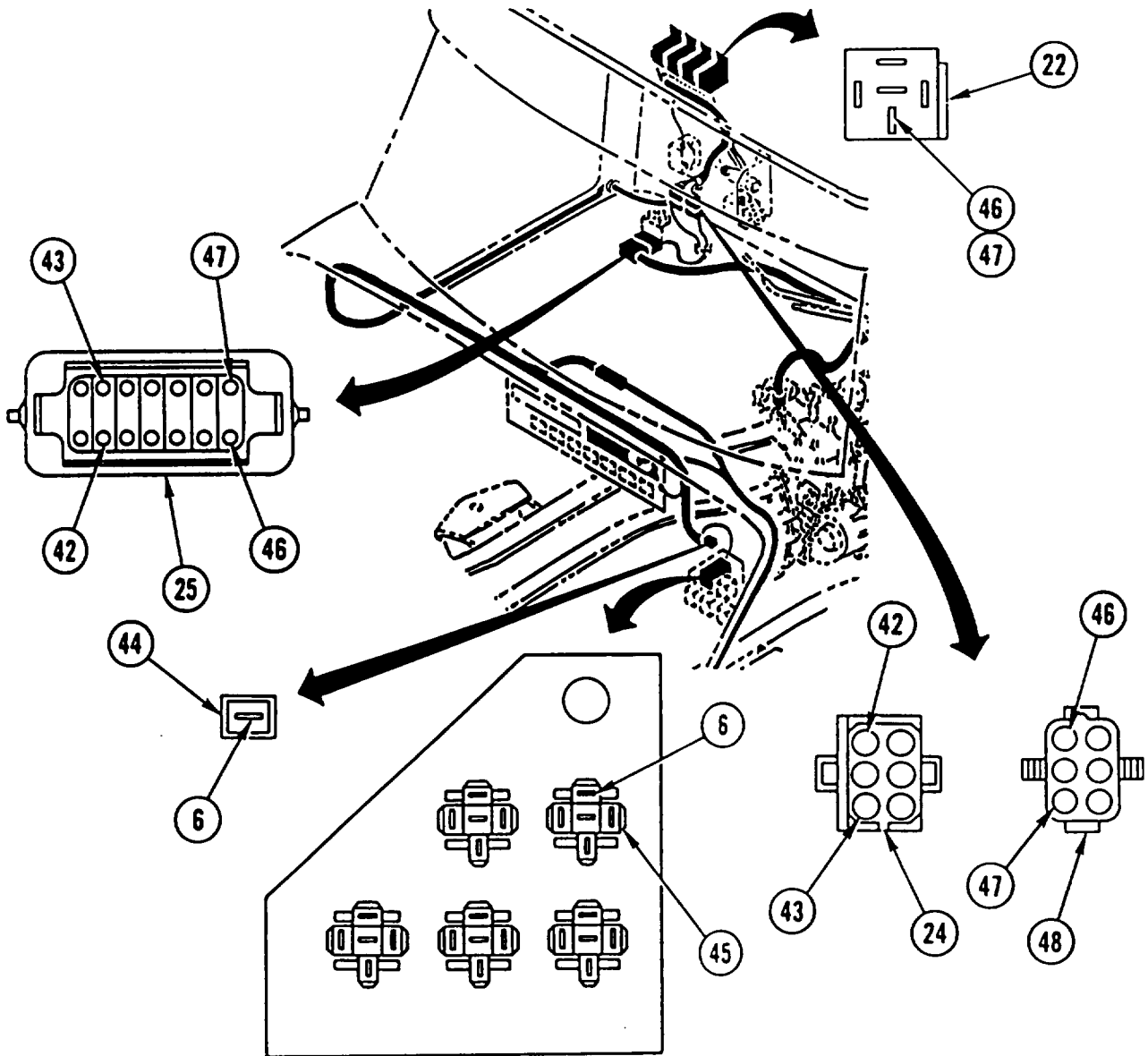

Table 3-5. Troubleshooting (Cont)

Malfunction	Test or Inspection	Corrective Action
ELECTRICAL SYSTEM (CONT)		
Step 33.	Check for +24 VDC between wire (42) and wire (43) and ground at connector AB (24).	<ul style="list-style-type: none"> ● If +24 VDC is present, repair wiring (42) and wiring (43) between connector AB and fuse box 3. ● If +24 VDC is not present, go to step 34.
Step 34.	Check for +24 VDC between wire (42) and wire (43) and ground at cab floor separation point (25).	<ul style="list-style-type: none"> ● If +24 VDC is not present, repair wiring (42) and wiring (43) between NATO slave receptacle and cab floor separation point. ● If +24 VDC is present, repair wiring (42) and wiring (43) between cab floor separation point and connector AB.
Step 35.	Check for +24 VDC between wire (6) and ground at connector W (44).	<ul style="list-style-type: none"> ● If +24 VDC is present, repair wiring (6) between D+ relay and connector W. ● If +24 VDC is not present, go to step 36.
Step 36.	Check for +24 VDC between wire (6) and ground at relay K2 (45).	<ul style="list-style-type: none"> ● If +24 VDC is not present, perform Malfunction 2. ● If +24 VDC is present, repair wiring 286 between connector W and relay K2.
Step 37.	Check for +24 VDC between wire (46) and wire (47) and ground at motor relay (22).	<ul style="list-style-type: none"> ● If +24 VDC is not present, go to step 41. ● If +24 VDC is present, go to step 38.
Step 38.	Check for +24 VDC between wire (46) and wire (47) and ground at connector AA (48).	<ul style="list-style-type: none"> ● If +24 VDC is not present, repair wiring (46) and wiring (47) between motor relay and connector AA. ● If +24 VDC is present, go to step 39.
Step 39.	Check for +24 VDC between wire (46) and wire (47) and ground at cab floor separation point (25).	<ul style="list-style-type: none"> ● If +24 VDC is not present, repair wiring (46) and wiring (47) between connector AA and cab floor separation point. ● If +24 VDC is present, go to step 40.

Table 3-5. Troubleshooting (Cont)

Malfunction

Test or Inspection

Corrective Action

ELECTRICAL SYSTEM (CONT)

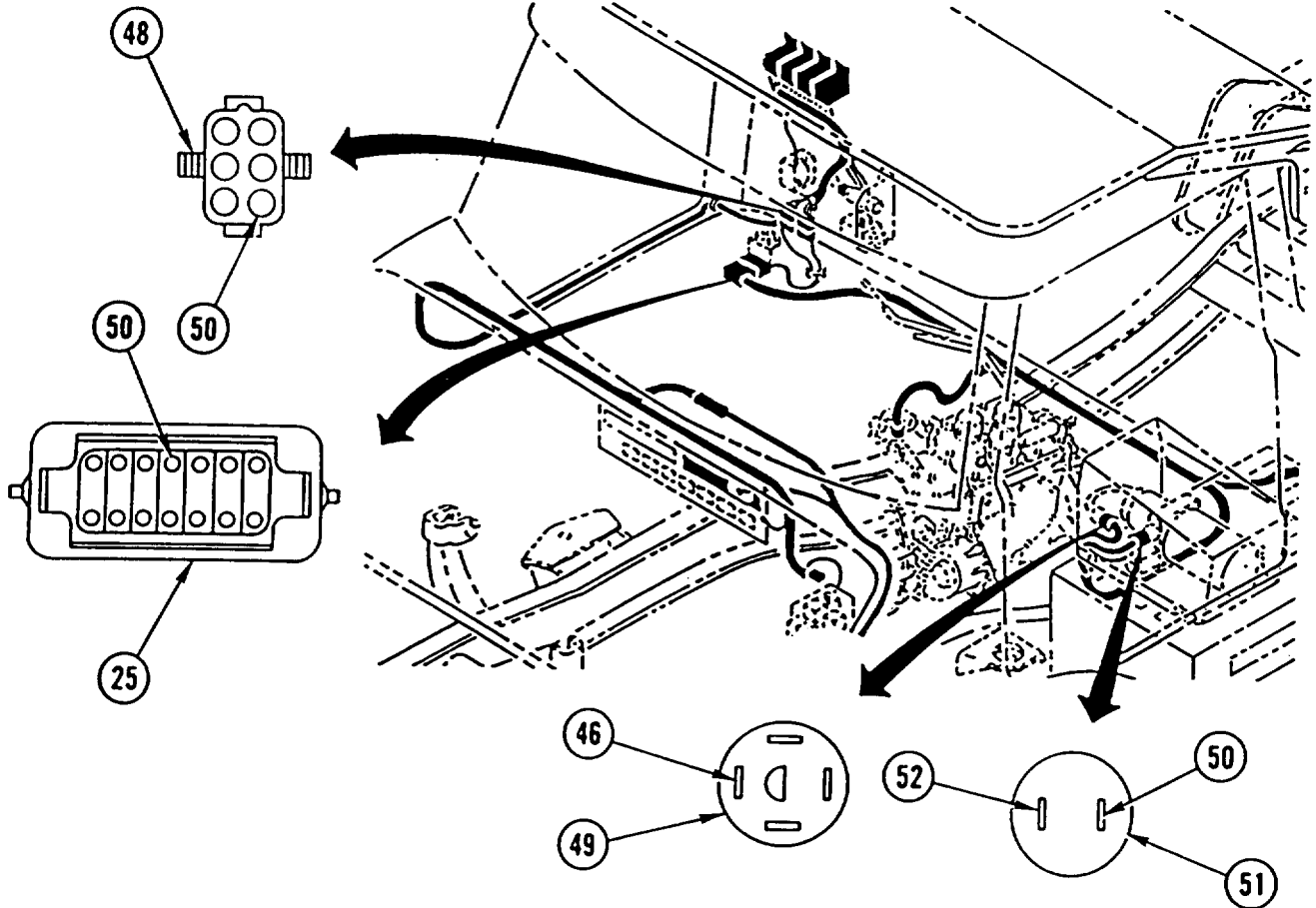

Step 40. Check for +24 VDC between wire (46) and wire (47) and ground at suspension lockout pump motor connector (49).

- If +24 VDC is not present, repair wiring (46) and wiring (47) between cab floor separation point and pump motor connector.
- If +24 VDC is present, replace hydraulic suspension lockout pump (page 4-51 1).

Step 41. Check for +24 VDC between wire (50) and ground at connector AA (48).

- If +24 VDC is not present, repair wiring (50) between D+ relay and connector AA.
- If +24 VDC is present, go to step 42.

Table 3-5. Troubleshooting (Cont)

Malfunction	Test or Inspection	Corrective Action
-------------	--------------------	-------------------

ELECTRICAL SYSTEM (CONT)

- Step 42. Check for +24 VDC between wire (50) and ground at cab floor separation point (25).
- If +24 VDC is not present, repair wiring (50) between connector AA and cab floor separation point.
 - If +24 VDC is present, go to step 43.
- Step 43. Check for +24 VDC between wire (50) and ground at hydraulic switch (51).
- If +24 VDC is not present, repair wiring (50) between cab floor separation point and hydraulic switch.
 - If +24 VDC is present, go to step 44.
- Step 44. Check for +24 VDC between wire (52) and ground at hydraulic switch (51).
- If +24 VDC is not present, replace hydraulic suspension lockout pump (page 4-511).
 - If +24 VDC is present, go to step 45.

Table 3-5. Troubleshooting (Cont)

Malfunction	Test or Inspection	Corrective Action
-------------	--------------------	-------------------

ELECTRICAL SYSTEM (CONT)

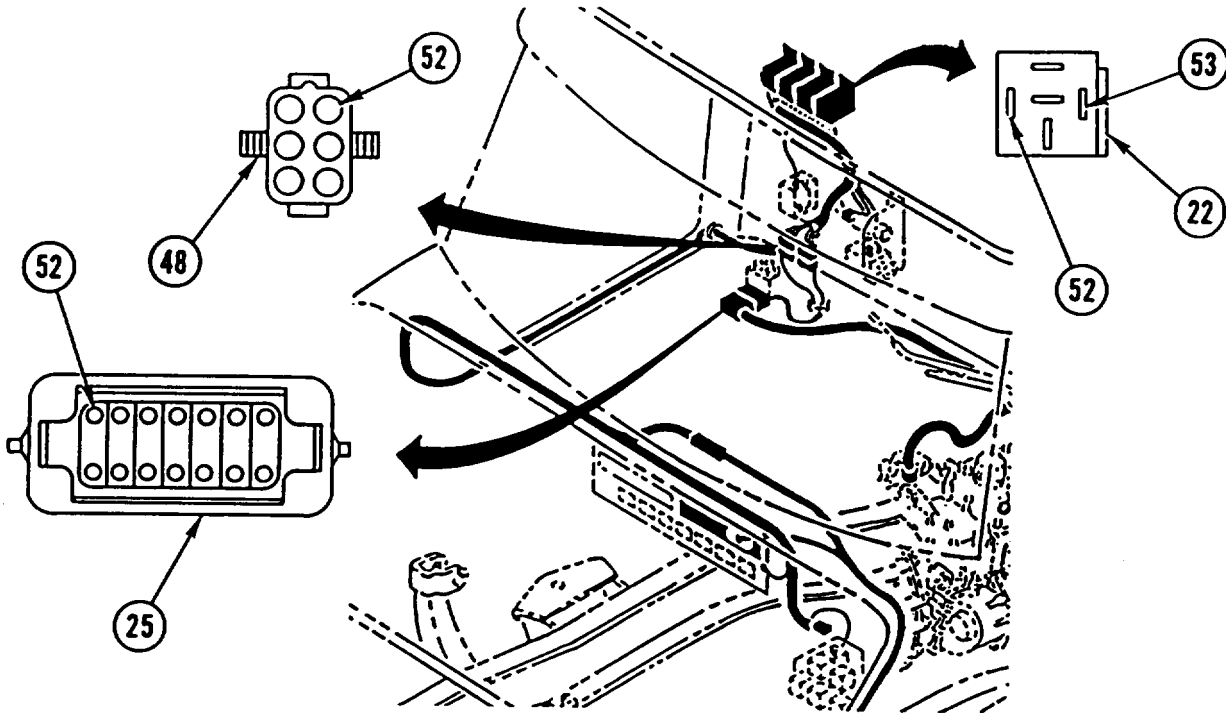

Step 45. Check for +24 VDC between wire (52) and ground at cab floor separation point (25).

- If +24 VDC is not present, repair wiring (52) between hydraulic switch and cab floor separation point.
- If +24 VDC is present, go to step 46.

Step 46. Check for +24 VDC between wire (52) and ground at connector AA (48).

- If +24 VDC is not present, repair wiring (52) between cab floor separation point and connector AA.
- If +24 VDC is present, go to step 47.

Step 47. Check for +24 VDC between wire (52) and ground at motor relay (22).

- If +24 VDC is not present, repair wiring (52) between connector AA and motor relay.
- If +24 VDC is present, go to step 48.

Step 48. Check wire (53) at motor relay (22) for continuity to ground.

- If short to ground, replace motor relay.
- If open to ground, repair wiring (53) between motor relay and ground.

Table 3-5. Troubleshooting (Cont)

Malfunction	Test or Inspection	Corrective Action
-------------	--------------------	-------------------

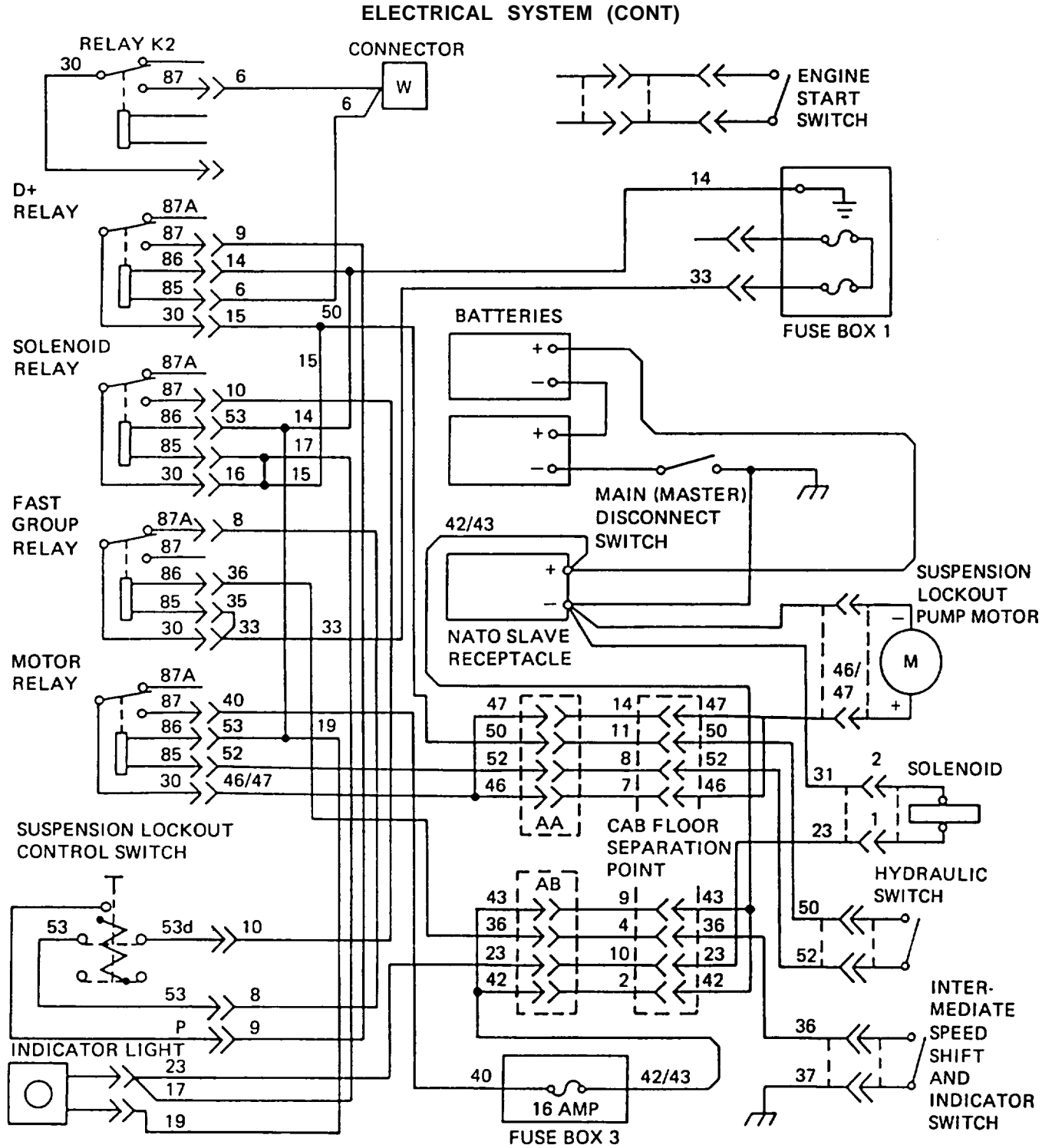

Table 3-5. Troubleshooting (Cont)

Malfunction	Test or Inspection	Corrective Action
-------------	--------------------	-------------------

ELECTRICAL SYSTEM (CONT)

74. HYDRAULIC OIL COOLER FANS WILL NOT OPERATE.

NOTE

- Vehicle MASTER disconnect switch must be ON and ignition switch set to ON. Failure to do so will cause erroneous results.
- Refer to wiring diagram (page 3-256) for all wiring repair steps.

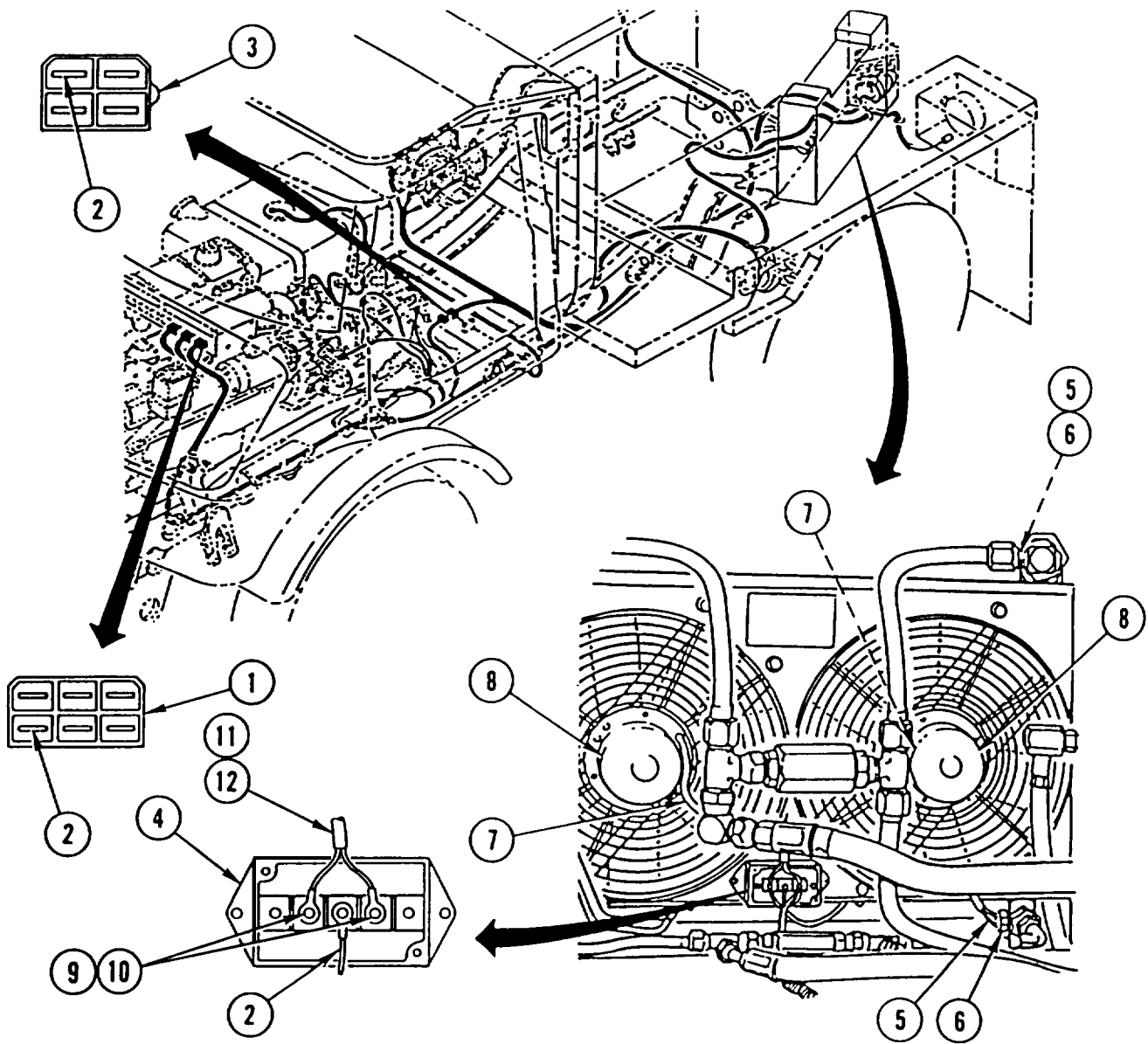

Table 3-5. Troubleshooting (Cont)

Malfunction	Test or Inspection	Corrective Action
ELECTRICAL SYSTEM (CONT)		
Step 1.	Disconnect connector A (1) and check for +24 VDC between wire 70 (2) and ground.	<ul style="list-style-type: none"> • If +24 VDC is not present, repair wiring 70 between connector A and fuse box 1. • If +24 VDC is present, reconnect connector A and go to step 2.
Step 2.	Disconnect connector X (3) and check for +24 VDC between wire 70 (2) and ground.	<ul style="list-style-type: none"> • If +24 VDC is not present, repair wiring 70 between connector X and connector A. • If +24 VDC is present, reconnect connector X and go to step 3.
Step 3.	Check for +24 VDC between wire 70 (2) and ground at hydraulic oil cooler terminal board (4).	<ul style="list-style-type: none"> • If +24 VDC is not present, repair wiring 70 between connector X and hydraulic oil cooler. • If +24 VDC is present, go to step 4.
Step 4.	Check for continuity of black and red wires (5) between hydraulic oil cooler terminal board (4) and hydraulic oil cooler thermal switches (6).	<ul style="list-style-type: none"> • if there is no continuity, repair black or red wire between hydraulic oil cooler thermal switches and hydraulic oil cooler terminal board. • If there is continuity, go to step 5.
Step 5.	Check for continuity of black and red wires (7) between hydraulic oil cooler terminal board (4) and fan motors (8).	<ul style="list-style-type: none"> • If there is no continuity, repair black or red wire between fan motors and hydraulic oil cooler terminal board. • If there is continuity, go to step 6.
Step 6.	Remove two screws (9) and two lock washers (10).	
Step 7.	Disconnect red wires (11 and 12) and short them to wire 70 (2).	<ul style="list-style-type: none"> • If fans do not operate, replace hydraulic oil cooler (page 4-722). • If fans operate, replace both hydraulic oil cooler thermal switches (page 4-1 47).

Table 3-5. Troubleshooting (Cont)

Malfunction	Test or Inspection	Corrective Action
-------------	--------------------	-------------------

ELECTRICAL SYSTEM (CONT)

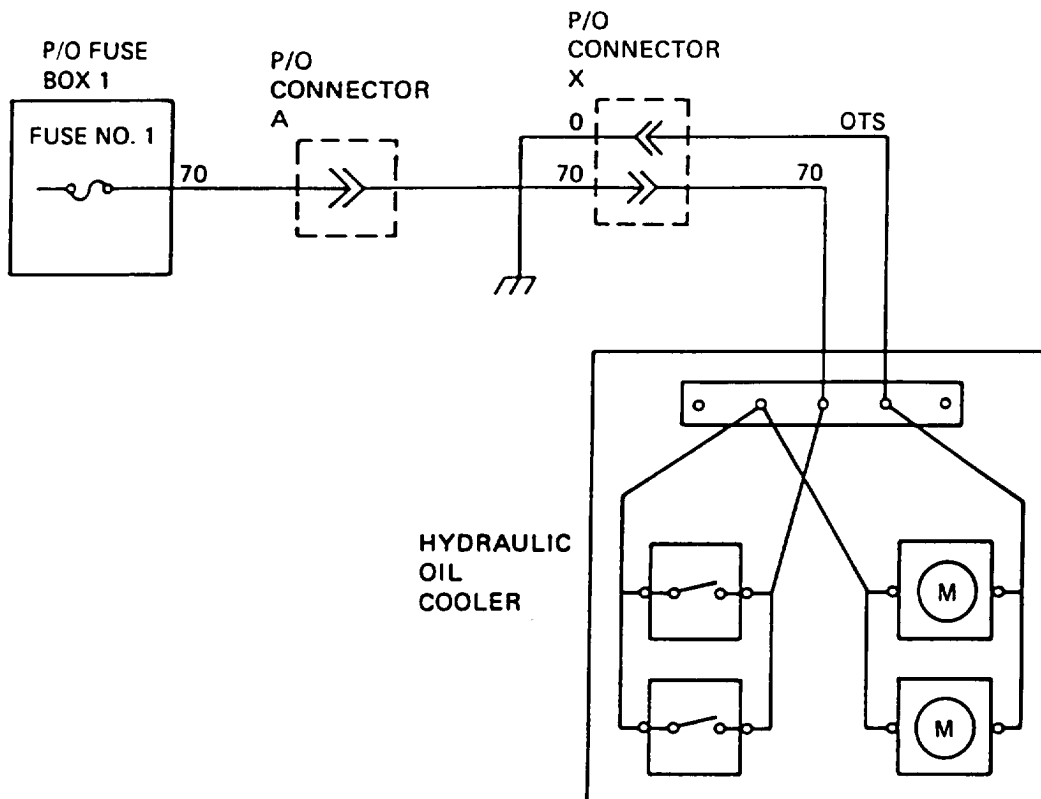

75. THROTTLE CONTROL SWITCH WILL NOT OPERATE (SEE).

NOTE

- Vehicle MASTER disconnect switch must be ON and ignition switch set to ON. Failure to do so will cause erroneous results.
 - Refer to wiring diagram (page 3-258) for all wiring repair steps.
- Step 1. Check for +24 VDC between wire 70T (1) and ground at tool switch (2).
- If +24 VDC is not present, repair wiring 70T between tool switch and connector X.
 - If +24 VDC is present, go to step 2.
- Step 2. With tool switch (2) pulled on, check for +24 VDC between wire 71V (3) and ground at tool switch.
- If +24 VDC is not present, replace tool switch (page 4-162).
 - If +24 VDC is present, go to step 3.

Table 3-5. Troubleshooting (Cont)

Malfunction	Test or Inspection	Corrective Action
-------------	--------------------	-------------------

ELECTRICAL SYSTEM (CONT)

Step 3. With tool switch (2) pulled on, check for +24 VDC between wire 71V (3) and ground at throttle control switch (4).

- If +24 VDC is not present, repair wiring 71 V between throttle control switch and tool switch.
- If +24 VDC is present, replace throttle control switch (page 4-1 54).

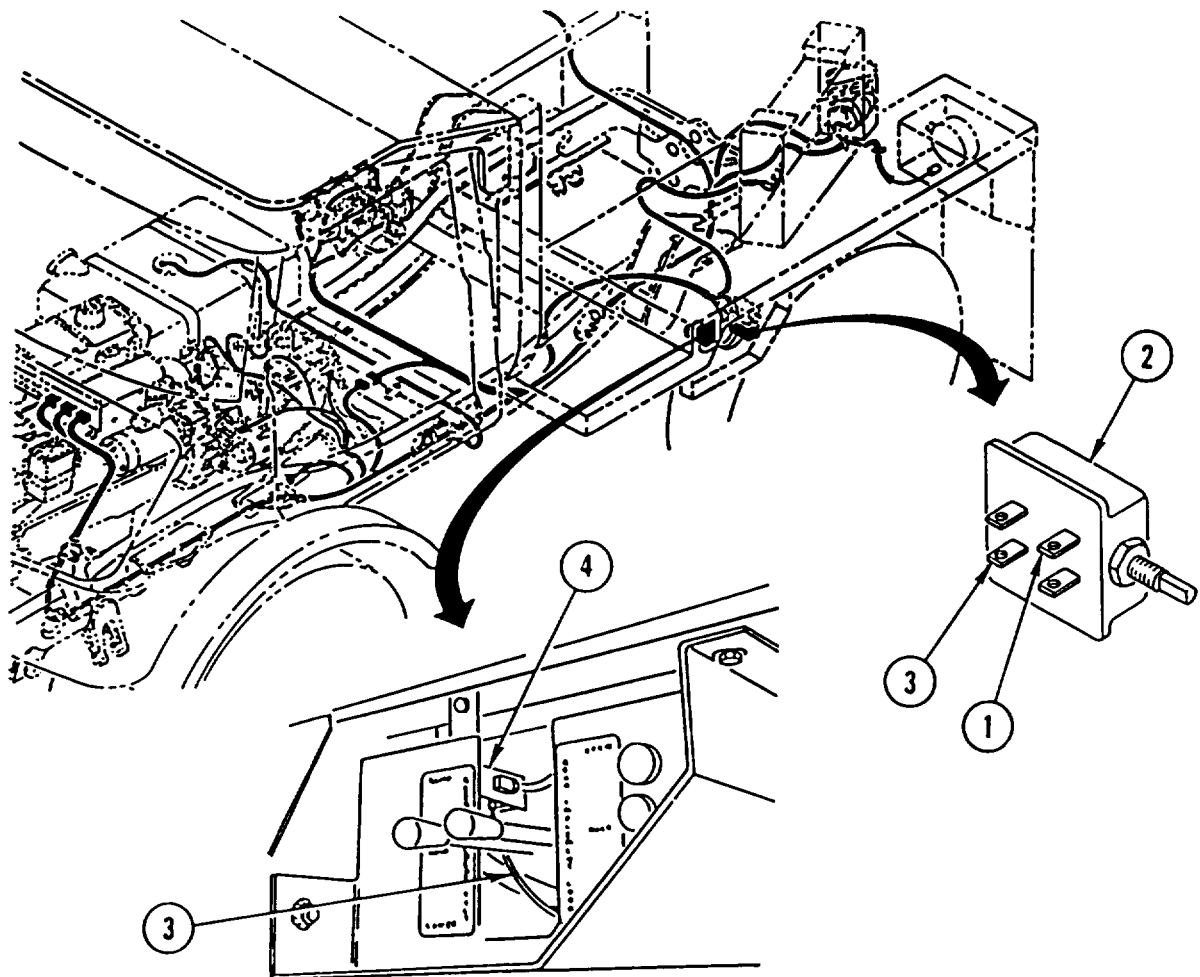
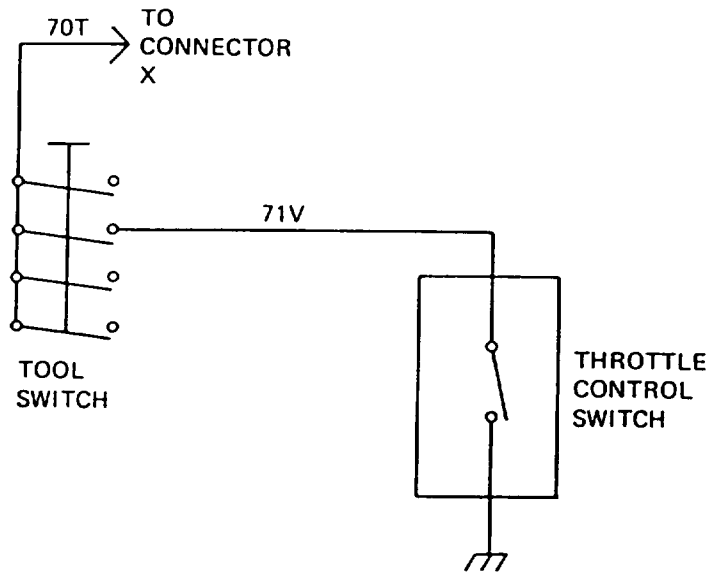

Table 3-5. Troubleshooting (Cont)

Malfunction	Test or Inspection	Corrective Action
-------------	--------------------	-------------------

ELECTRICAL SYSTEM (CONT)



76. ALL MACHINE (HYDRAULIC) TOOLS WILL NOT OPERATE

NOTE

- Vehicle MASTER disconnect switch must be ON and ignition switch set to ON. Failure to do so will cause erroneous results.
 - Refer to wiring diagram for all wiring repair steps.
- Step 1. Check for +24 VDC between wire 70T (1) and ground at tool switch (2).
- If +24 VDC is not present, repair wiring 70T between tool switch and connector X.
 - If +24 VDC is present, go to step 2.
- Step 2. With tool switch (2) pulled on, check for +24 VDC between wire 71T (3) and ground at tool switch.
- If +24 VDC is not present, replace tool switch (page 4-162).
 - If +24 VDC is present, go to step 3.
- Step 3. With tool switch (2) pulled on, check for +24 VDC between wire 71T (3) and ground at machine tool solenoid (4).
- If +24 VDC is not present, repair wiring 71T between tool switch and machine tool solenoid.
 - If +24 VDC is present, notify direct support maintenance.

Table 3-5. Troubleshooting (Cont)

Malfunction	Test or Inspection	Corrective Action
-------------	--------------------	-------------------

ELECTRICAL SYSTEM (CONT)

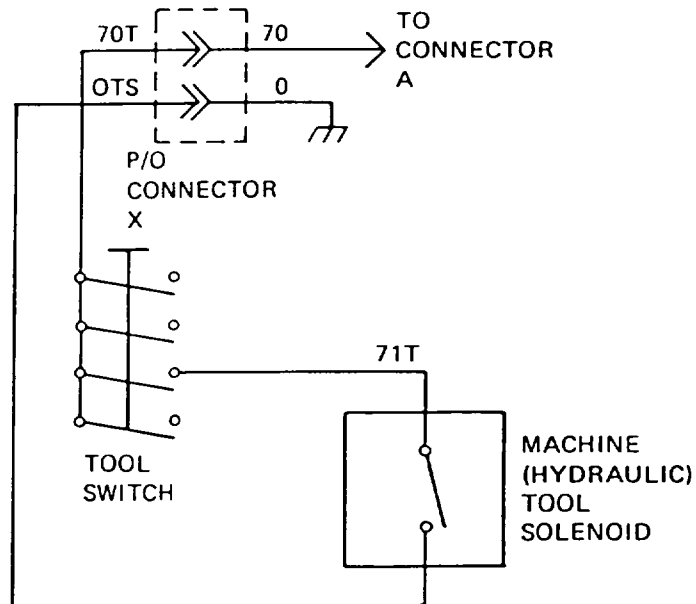
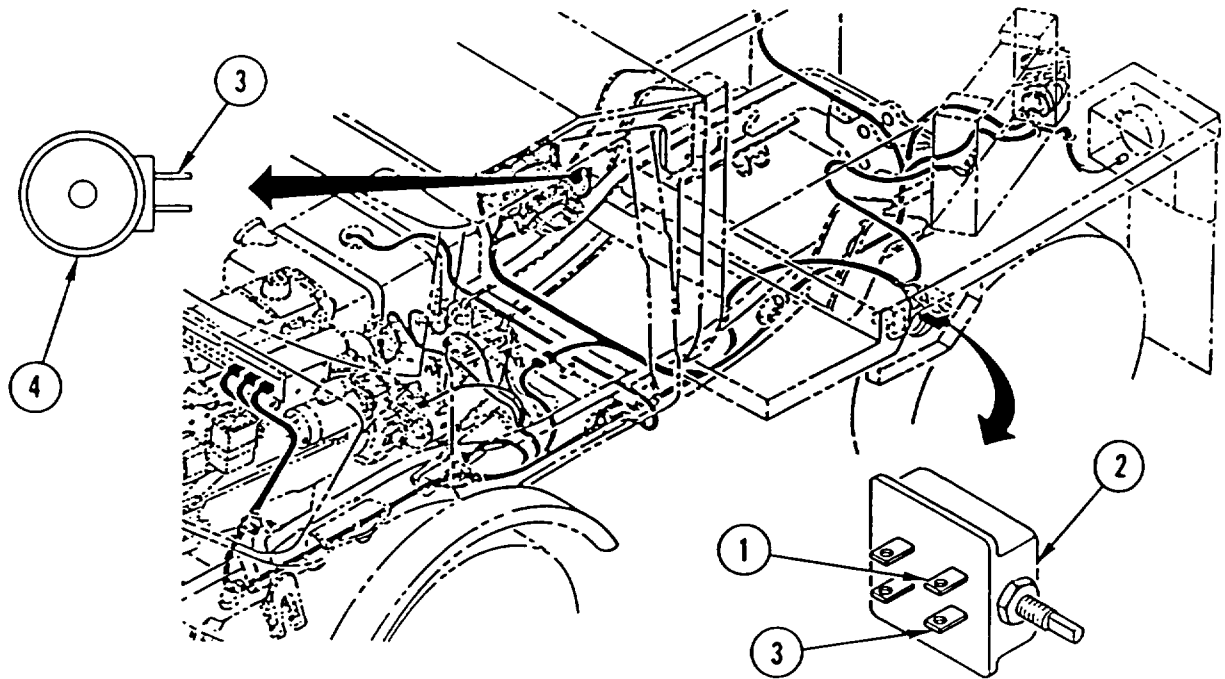

Table 3-5. Troubleshooting (Cont)

Malfunction

Test or Inspection

Corrective Action

ELECTRICAL SYSTEM (CONT)

77. FRONT LOADER WILL NOT OPERATE USING BUCKET SWITCH (SEE).

NOTE

- Vehicle MASTER disconnect switch must be ON and ignition switch set to ON. Failure to do so will cause erroneous results.
- Refer to wiring diagram for all wiring repair steps.

Step 1. Check for +24 VDC between wire 70S (1) and ground at bucket switch (2).

- If +24 VDC is not present, repair wiring 70S between bucket switch and connector X.
- If +24 VDC is present, go to step 2.

NOTE

Perform steps 2 and 3 for failure in down (ON) position. Perform steps 4 and 5 for failure in UP position.

Step 2. With bucket switch (2) in DN position, check for +24 VDC between wire 71 U (3) and ground at bucket switch.

- If +24 VDC is not present, replace bucket switch (page 4-1 51).
- If +24 VDC is present, go to step 3.

Step 3. With bucket switch (2) in DN position, check for +24 VDC between wire 71 U (3) and ground at bucket solenoid (4).

- If +24 VDC is not present, repair wiring 71 U between bucket switch and bucket solenoid.
- If +24 VDC is present, notify direct support maintenance.

Step 4. With bucket switch (2) in UP position, check for +24 VDC between wire 710 (5) and ground at bucket switch.

- If +24 VDC is not present, replace bucket switch (page 4-151).
- If +24 VDC is present, go to step 5.

Step 5. With bucket switch (2) in UP position, check for +24 VDC between wire 71 D (5) and ground at bucket solenoid (6).

- If +24 VDC is not present, repair wiring 71 D between bucket switch and bucket solenoid.
- If +24 VDC is present, notify direct support maintenance.

Table 3-5. Troubleshooting (Cont)

Malfunction	Test or Inspection	Corrective Action
-------------	--------------------	-------------------

ELECTRICAL SYSTEM (CONT)

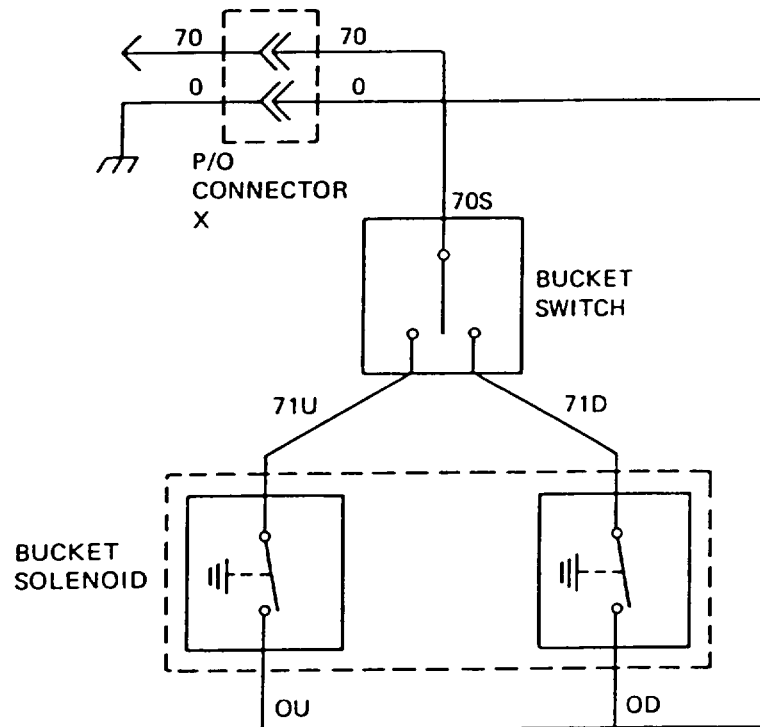
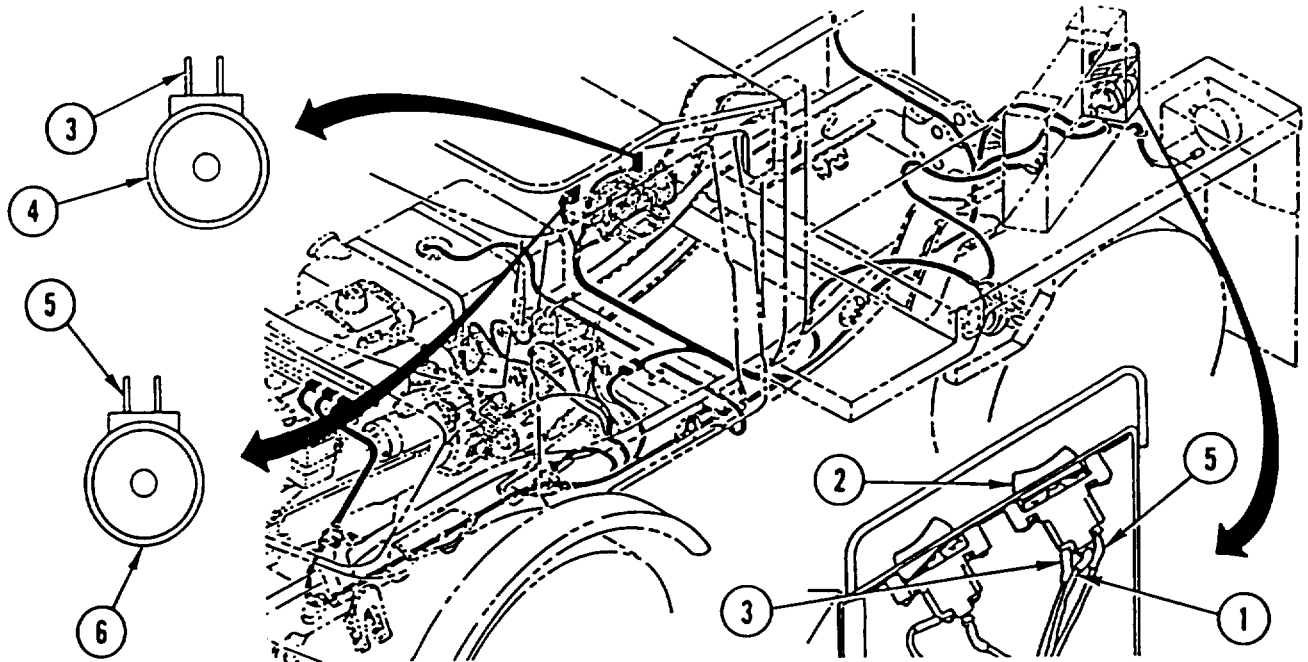

Table 3-5. Troubleshooting (Cont)

Malfunction	Test or Inspection	Corrective Action
-------------	--------------------	-------------------

ELECTRICAL SYSTEM (CONT)

78. THROTTLE CONTROL SWITCH WILL NOT OPERATE (HMMH).

NOTE

- Vehicle MASTER disconnect switch must be ON and ignition switch set to ON. Failure to do so will cause erroneous results.
- Refer to wiring diagram (page 3-264) for all wiring repair steps.

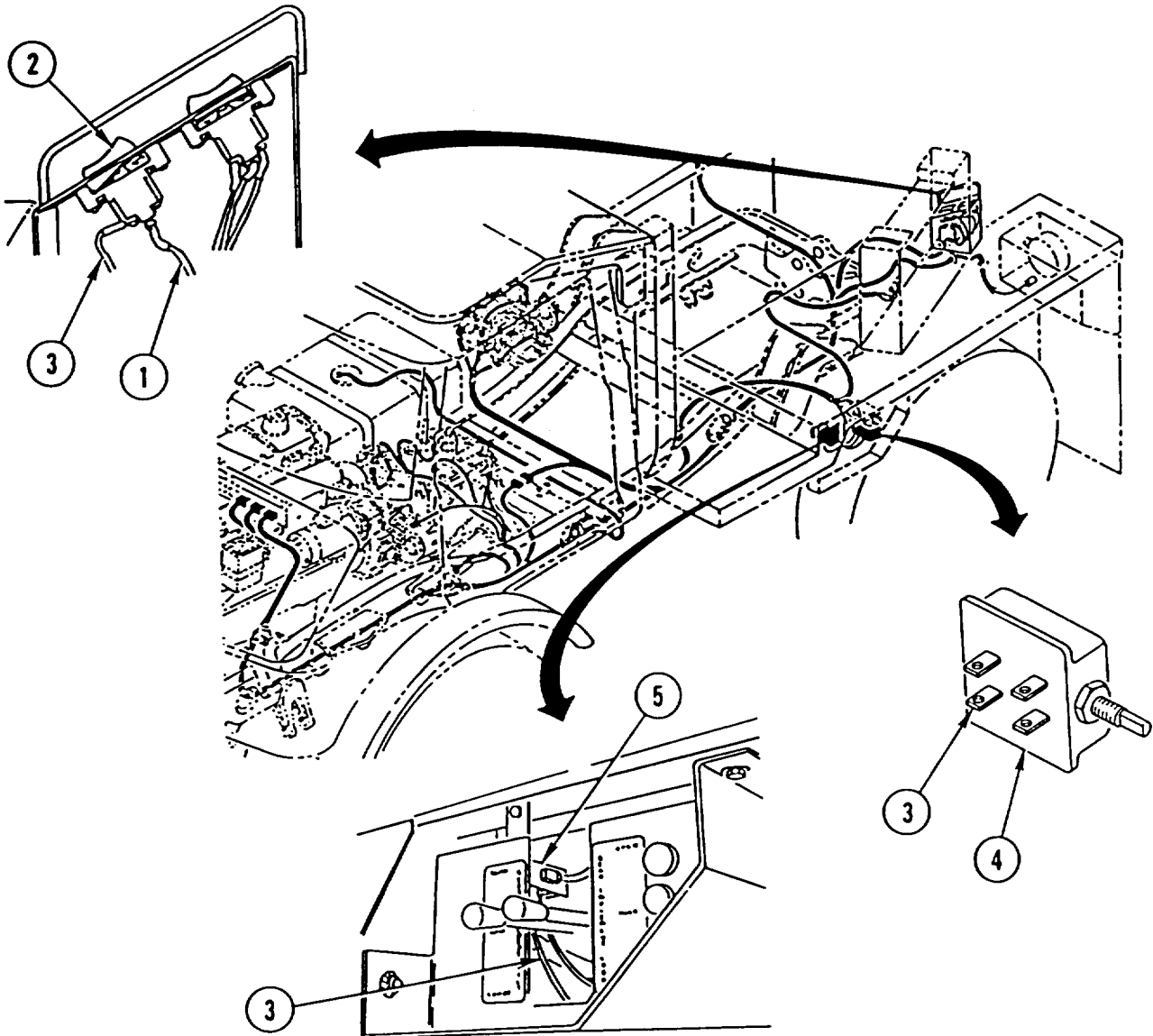

Table 3-5. Troubleshooting (Cont)

Malfunction	Test or Inspection	Corrective Action
ELECTRICAL SYSTEM (CONT)		
	Step 1. Check for +24 VDC between wire 70M (1) and ground at auxiliary throttle switch (2).	<ul style="list-style-type: none"> • If +24 VDC is not present, repair wiring 70M between auxiliary throttle switch and connector X. • If +24 VDC is present, go to step 2.
	Step 2. With auxiliary throttle switch (2) in CRANE position, check for +24 VDC between wire 73V (3) and ground at auxiliary throttle switch.	<ul style="list-style-type: none"> • If +24 VDC is not present, replace auxiliary throttle switch (page 4-156). • If +24 VDC is present, go to step 3.
	Step 3. With auxiliary throttle switch (2) in CRANE position, check for +24 VDC between wire 73V (3) and ground at tool switch (4).	<ul style="list-style-type: none"> • If +24 VDC is not present, repair wiring 73V between auxiliary throttle switch and tool switch. • If +24 VDC is present, go to step 4.
	Step 4. With auxiliary throttle switch (2) in CRANE position, check for +24 VDC between wire 73V (3) and ground at throttle control switch (5).	<ul style="list-style-type: none"> • If +24 VDC is not present, repair wiring 73V between tool switch and throttle control switch. • If +24 VDC is present, replace throttle control switch (page 4-158).

Table 3-5. Troubleshooting (Cont)

Malfunction
 Test or Inspection
 Corrective Action

ELECTRIIAL SYSTEM (CONT)

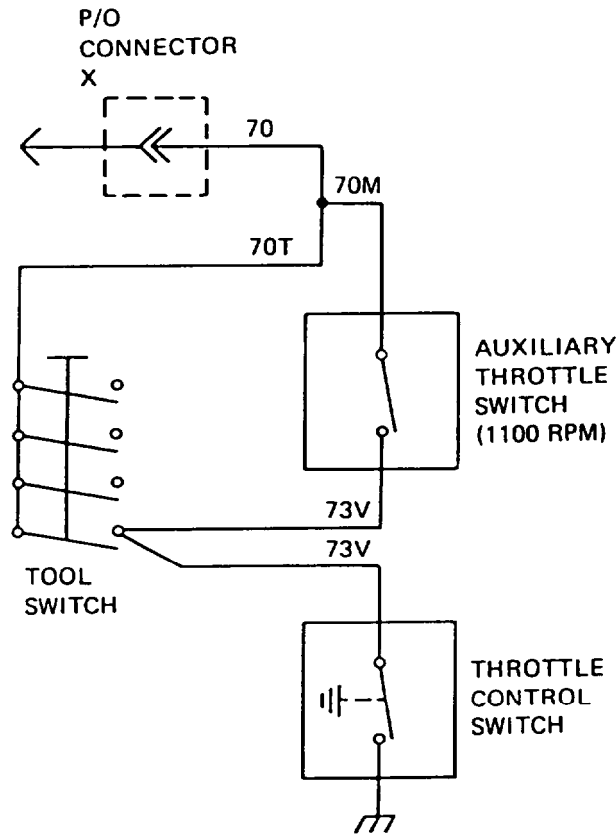

79. TRANSMISSION WILL NOT OPERATE IN ANY FORWARD OR REVERSE GEAR.

Check clutch slave cylinder for proper adjustment as follows:

- a. Remove return spring (1) from slave cylinder (2) and clutch lever (3).
- b. Loosen lock nut (4) and back out adjusting screw (5) completely.
- c. Move clutch lever (3) down until it stops. Clearance between clutch lever (3) and adjusting screw (5) must be 1/8 in. (3 +0.05 mm).
 - If clutch slave cylinder is not property adjusted, adjust clutch slave cylinder (page 4-21).
 - If clutch slave cylinder is property adjusted, notify direct support maintenance.

Table 3-5. Troubleshooting (Cont)

Malfunction	Test or Inspection	Corrective Action
-------------	--------------------	-------------------

TRANSMISSION (CONT)

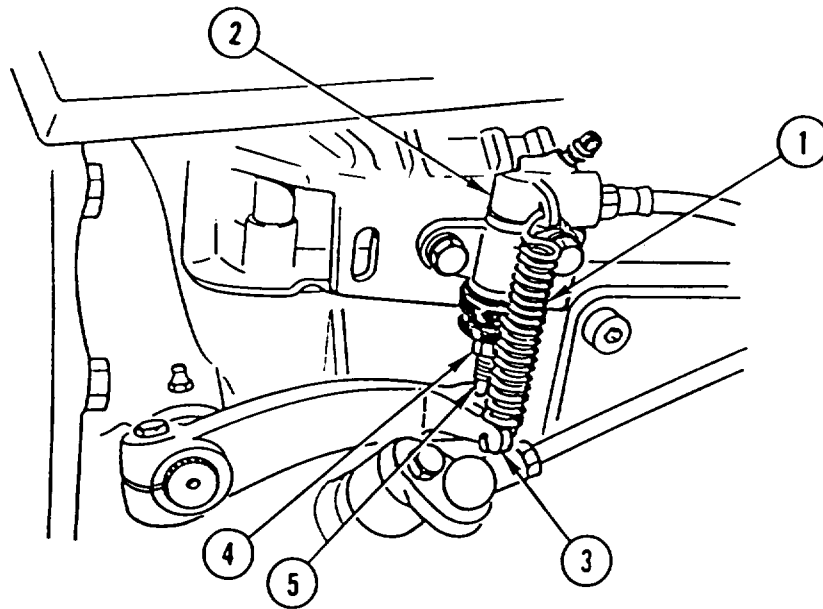

80. TRANSMISSION SLIPS IN ALL RANGES.

Step 1. Check for “spongy” feel while depressing clutch pedal.

- If clutch pedal feels spongy, bleed brake system (**page 4-262**).
- If clutch pedal does not feel spongy, go to step 2.

Step 2. Check for low oil level in clutch hydraulic reservoir.

- If oil level is low, add oil (LO 5-2420 -224-1 2).
- If oil level is not low, go to step 3.

Step 3. Check clutch master cylinder for leaking oil.

- If clutch master cylinder is leaking oil, replace clutch master cylinder (**page 4-22**).
- If clutch master cylinder is not leaking oil, go to step 4.

Step 4. Check clutch slave cylinder for leaking oil.

- If clutch slave cylinder is leaking oil, replace clutch slave cylinder (**page 4-19**).
- If clutch slave cylinder is not leaking oil, go to step 5.

Table 3-5. Troubleshooting (Cont)

Malfunction	Test or Inspection	Corrective Action
-------------	--------------------	-------------------

TRANSMISSION (CONT)

Step 5. Check clutch slave cylinder for proper adjustment as follows:

- a. Remove return spring (1) from slave cylinder (2) and clutch lever (3).
- b. Loosen lock nut (4) and back out adjusting screw (5) completely.
- c. Move clutch lever (3) down until it stops. Clearance between clutch lever (3) and adjusting screw (5) must be 1/8 in. (3 +0.05 mm).
 - If clutch slave cylinder is not properly adjusted, adjust clutch slave cylinder (page 4-21).
 - If clutch slave cylinder is properly adjusted, notify direct support maintenance.

81. PTO WILL NOT ENGAGE.

Check for interference with shift lever.

- If there is no interference with shift lever, notify direct support maintenance.

82. ALL WHEEL DRIVE/DIFFERENTIAL LOCK WILL NOT ENGAGE/FSENGAGE.

Step 1. Check for low air pressure.

- If air pressure is less than 80 psi, go to Malfunction 89.
- If air pressure is 80 psi or greater, go to step 2.

Step 2. Check for loose and damaged air lines and fittings.

- If air lines and fittings are loose or damaged, notify direct support maintenance.
- If air lines and fittings are not loose or damaged, go to step 3.

Step 3. Check all wheel drive selector valve for binding and proper operation,

- If all wheel drive selector valve is binding or not operating property, replace all wheel drive selector valve (page 4-240).
- If all wheel drive selector valve is operating property and not binding, go to step 4.

Step 4. Check all wheel drive control cylinder for proper adjustment and operation.

- If all wheel drive control cylinder is not adjusted or operating property, adjust or replace all wheel drive control cylinder (page 4-243).
- If all wheel drive control cylinder is adjusted and operating properly, notify direct support maintenance.

Table 3-5. Troubleshooting (Cont)

Malfunction	Test or Inspection	Corrective Action
-------------	--------------------	-------------------

BRAKES AND AIR SYSTEM

CAUTION

When repairing disc brakes, make sure stretch bolts for fastening brake caliper to wheel hub drive housing are always fitted at side where disc emerges from pads. Failure to do so could cause damage to equipment.

NOTE

Replace disc brake pads in sets for entire axle.

83. BRAKES FAIL OR BRAKE PEDAL SPONGY.

Step 1. Check for low brake fluid level in brake fluid reservoir.

- If brake fluid level is low, add silicone brake fluid (LO 5-2420-224-12).
- If brake fluid level is not low, go to step 2.

Step 2. Check for leaking and damaged hydraulic brake lines and fittings.

- If hydraulic brake lines and fittings are leaking or damaged, tighten or replace brake lines and fittings (pages 4-278, 4-280, 4-282, 4-284).
- If hydraulic brake lines and fittings are not leaking or damaged, go to step 3.

Step 3. Check for air in hydraulic brake system.

- If there is air in hydraulic brake system, bleed brake system (page 4-262).
- If there is no air in hydraulic brake system, replace brake master cylinder (page 4-276).

84. BRAKING UNEVEN.

Step 1. Check hydraulic brake lines for kinks and restrictions.

- If there are kinks or restrictions in hydraulic brake lines, replace brake lines (pages 4-278, 4-280, 4-282, 4-284).
- If there are no kinks or restrictions in hydraulic brake lines, go to step 2.

Table 3-5. Troubleshooting (Cont)

Malfunction	Test or Inspection	Corrective Action
-------------	--------------------	-------------------

BRAKES AND AIR SYSTEM (CONT)

NOTE

Step 2 is for front brakes only.

Step 2. Check dust cover for damage.

- If dust cover is damaged, replace dust cover (page 4-271).
- If dust cover is not damaged, go to step 3.

Step 3. Check for damaged spring clip and retaining pins.

- If spring clip or retaining pins are damaged, replace spring clip (page 4-268) or retaining pins (page 4-271).
- If spring clip or retaining pins are not damaged, go to step 4.

Step 4. Check for disc brake pads worn to 0.08 in. (2 mm) or less.

- If disc brake pads are worn, replace pads in sets (pages 4-268, 4-271).
- If disc brake pads are not worn, go to step 5.

Step 5. Check for oily disc brake pads.

- If disc brake pads are oily, replace pads in sets (pages 4-268, 4-271) and replace axle final drive outer seal (pages 4-247, 4-248).
- If disc brake pads are not oily, go to step 6.

Step 6. Check for scored disc surface.

- If disc surface is scored, replace disc (page 4-265).
- If disc surface is not scored, notify direct support maintenance.

85. BRAKES OVERHEAT.

Step 1. Check for sticking disc brake pads.

- If disc brake pads are sticking, replace pads in sets (pages 4-268, 4-271).
- If disc brake pads are not sticking, go to step 2.

Step 2. Check for damaged spring clip, retaining pins, and wheel hub mounting.

- If spring clip, retaining pins, or wheel hub mounting are damaged, replace parts as required (pages 4-268, 4-271).
- If spring clip, retaining pins, or wheel hub mounting are not damaged, go to step 3.

Table 3-5. Troubleshooting (Cont)

Malfunction	Test or Inspection	Corrective Action
-------------	--------------------	-------------------

BRAKES AND AIR SYSTEM (CONT)

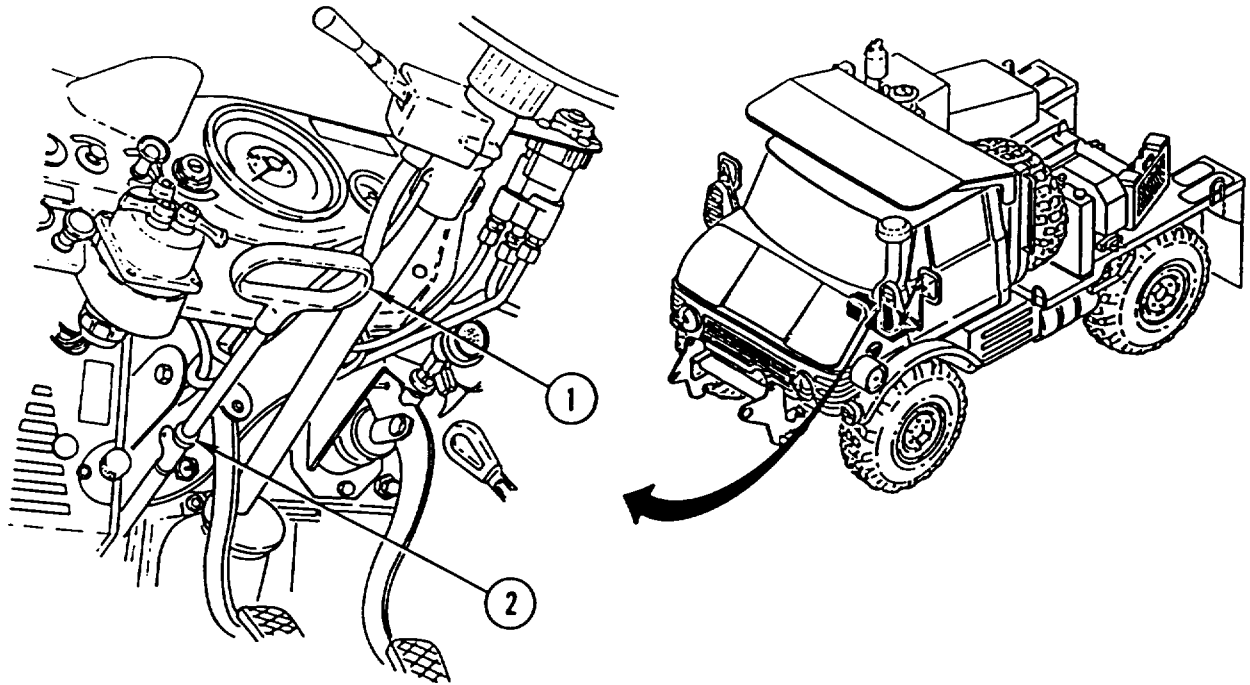
**NOTE**

Step 3 is for rear axle only.

Step 3. Check parking brake adjustment by pulling parking brake handle (1) and measuring distance from parking brake handle to stop (2). Distance should be 7-9 in. (180-220 mm).

- If parking brake is not properly adjusted, adjust parking brake (page 4-254).
- If parking brake is properly adjusted, go to step 4.

Table 3-5. Troubleshooting (Cont)

Malfunction	Test or Inspection	Corrective Action
-------------	--------------------	-------------------

BRAKES AND AIR SYSTEM (CONT)

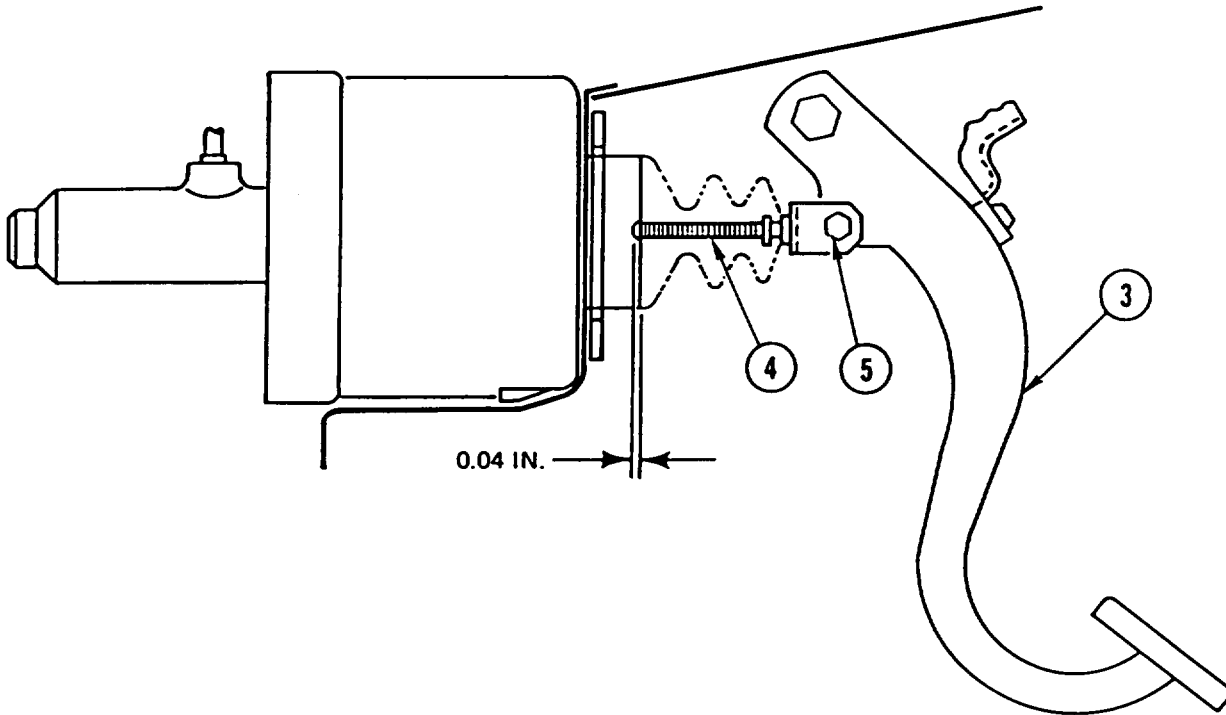

- Step 4. Check brake pedal (3) adjustment with brake pedal at neutral (brakes not applied). Piston rod (4) clearance must be 0.04 in. (1 mm).
- If piston rod clearance is not 0.04 in. (1 mm), adjust clearance by turning eccentric screw (5).
 - If piston rod clearance is 0.04 in. (1 mm), go to step 5.

- Step 5. Check for proper operation of air brake booster by depressing brake pedal and observing gage needle on dashboard for deflection.
- If air brake booster is not operating properly, replace air brake booster (page 4-295).
 - If air brake booster is operating properly, notify direct support maintenance.

86. BRAKES SQUEAL.

Check for dirty, glazed, and worn disc brake pads.

- If disc brake pads are glazed or worn, replace pads in sets (pages 4-268, 4-271).
- If disc brake pads are dirty, clean pads.

Table 3-5. Troubleshooting (Cont)

Malfunction	Test or Inspection	Corrective Action
-------------	--------------------	-------------------

BRAKES AND AIR SYSTEM (CONT)**87. BRAKE INDICATOR LIGHT LIGHTS.**

Step 1. Check for low brake fluid level in brake fluid reservoir.

- If brake fluid level is low, add silicone brake fluid (LO 5-2420-224-12).
- If brake fluid level is not low, go to step 2.

NOTE

Step 2 is for rear axle only.

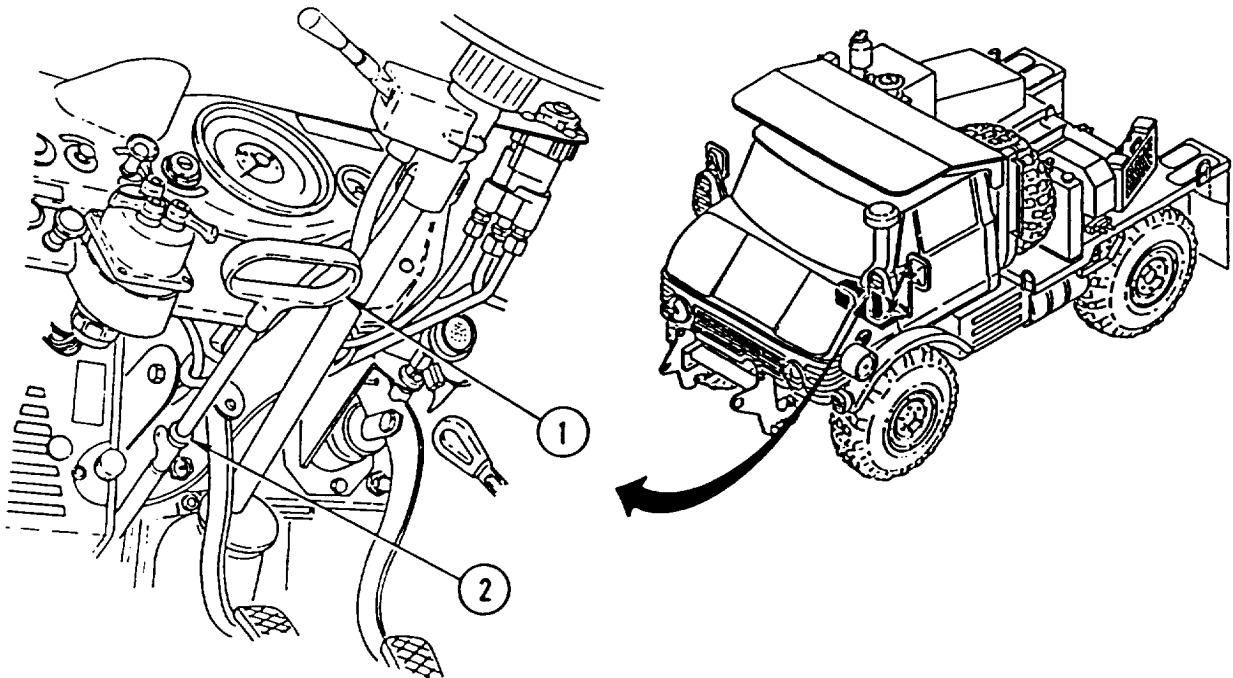

Step 2. Check parking brake adjustment by pulling parking brake handle (1) and measuring distance from parking brake handle to stop (2). Distance should be 7-9 in. (180-220 mm).

- If parking brake is not properly adjusted, adjust parking brake (page 4-254).
- If parking brake is properly adjusted, go to step 3.

Table 3-5. Troubleshooting (Cont)

Malfunction	Test or Inspection	Corrective Action
-------------	--------------------	-------------------

BRAKES AND AIR SYSTEM (CONT)

Step 3. Check for disc brake pads worn to 0.08 in. (2 mm) or less.

- If disc brake pads are worn, replace pads in sets (pages 4-268, 4-271).
- If disc brake pads are not worn, go to step 4.

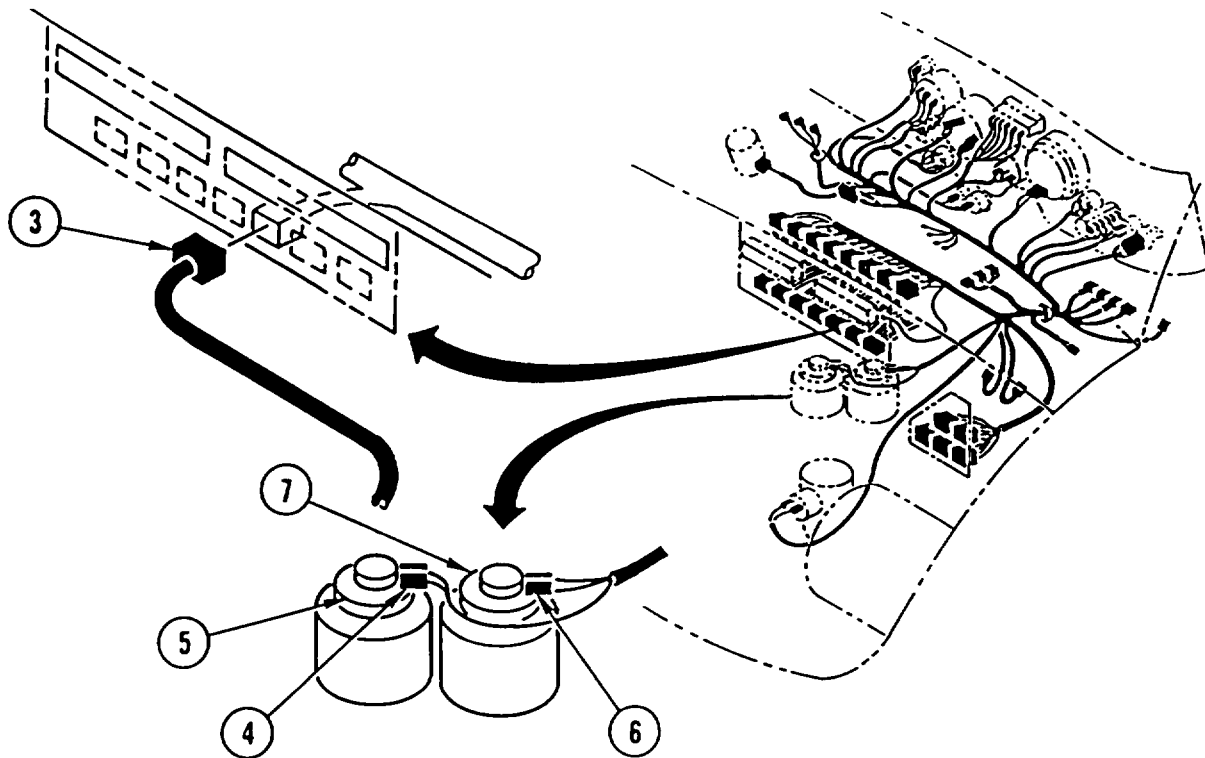

Step 4. Disconnect connector C (3) and check if brake indicator light is lit.

- If brake indicator light is not lit, reconnect connector C and go to step 7.
- If brake indicator light is lit, reconnect connector C and go to step 5.

Step 5. Disconnect wire 224 (4) from filler opening cap (5) and check if brake indicator light is lit.

- If brake indicator light is not lit, replace filler opening cap.
- If brake indicator light is lit, reconnect wire 224 and go to step 6.

Table 3-5. Troubleshooting (Cont)

Malfunction

Test or Inspection

Corrective Action

BRAKES AND AIR SYSTEM (CONT)

Step 6. Disconnect wire 223 (6) from filler opening cap (7) and check if brake indicator light is lit.

- If brake indicator light is not lit, replace filler opening cap.
- If brake indicator light is lit, repair wiring 223 between filler opening cap and brake indicator light.

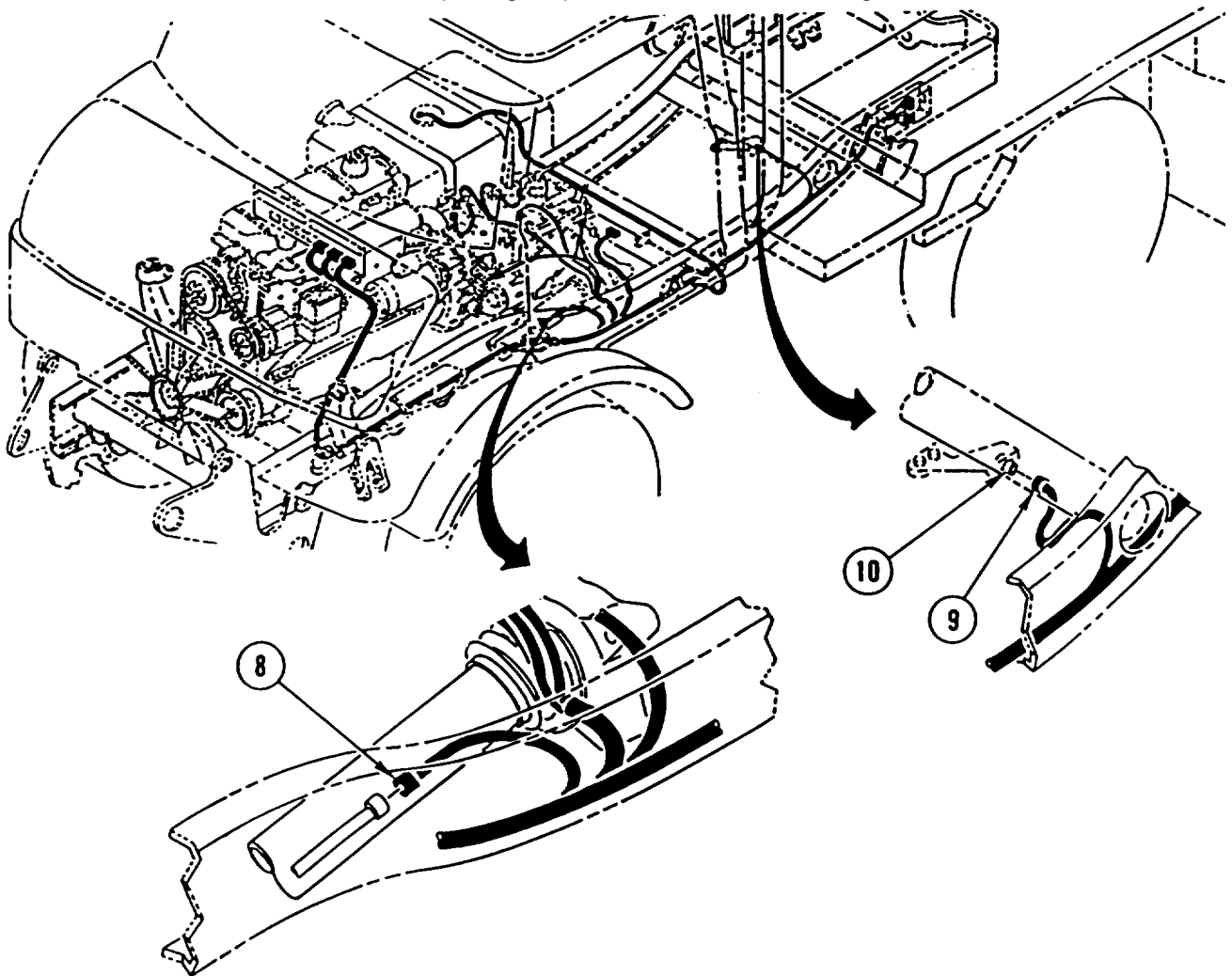

Step 7. Disconnect connector AF (8) and check if brake indicator light is lit.

- If brake indicator light is not lit, reconnect connector AF and go to step 9.
- If brake indicator light is lit, reconnect connector AF and go to step 8.

Table 3-5. Troubleshooting (Cont)

Malfunction	Test or Inspection	Corrective Action
-------------	--------------------	-------------------

BRAKES AND AIR SYSTEM (CONT)

Step 8. Disconnect parking brake switch connector (9) from parking brake switch (10) and check if brake indicator light is lit.

- If brake indicator light is not lit, replace parking brake switch (page 4-210).
- If brake indicator light is lit, repair wiring 332 and wiring 333 between connector C, connector AF, and parking brake switch connector.

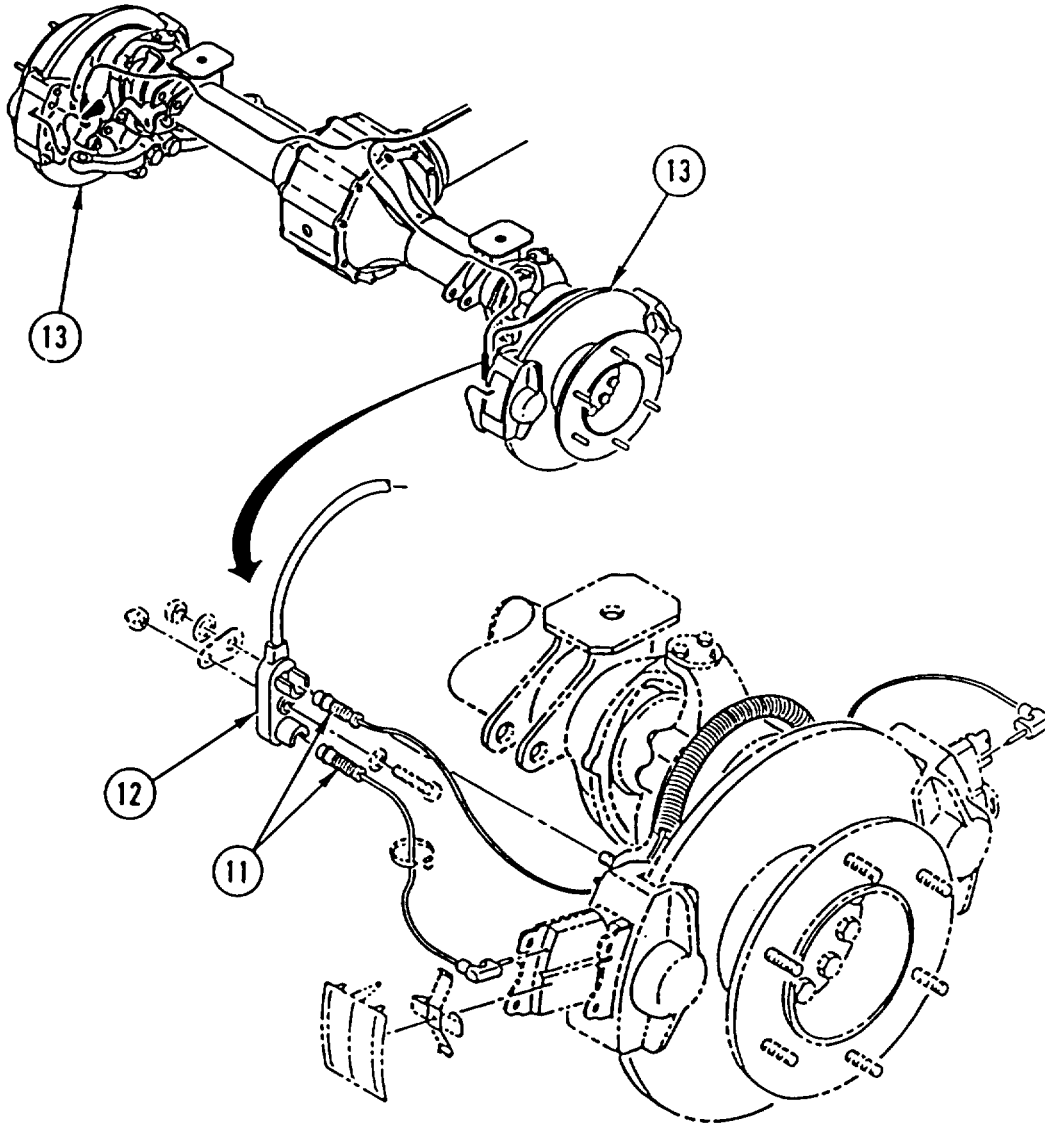

Table 3-5. Troubleshooting (Cont)

Malfunction	Test or Inspection	Corrective Action
-------------	--------------------	-------------------

BRAKES AND AIR SYSTEM (CONT)

Step 9. Disconnect hook switch leads (11) from front disc brake pad indicator wiring harness (12) at both front brake assemblies (13) and check if brake indicator light is lit.

- If brake indicator light is lit, replace front disc brake pad indicator wiring harness (page 4-231).
- If brake indicator light is not lit, go to step 10.

Step 10. With hook switch leads (11) disconnected, check continuity between hook switch leads and ground.

- Replace hook switch that shows short to ground.

88. TRAILER BRAKE SYSTEM FAILS OR BRAKING WEAK.

NOTE

Brake lever must be fully actuated and dual brake gage indicating normal pressure.

Step 1. Check for leaking and damaged brake hose couplings.

- If brake hose couplings are leaking or damaged, tighten or replace couplings (page 4-324).
- If brake hose couplings are not leaking or damaged, go to step 2.

Step 2. Check for air leaks around trailer air supply valve.

- If there are air leaks around trailer air supply valve, replace trailer air supply valve (page 4-331).
- If there are no air leaks around trailer air supply valve, go to step 3.

Step 3. Check for air leaks around trailer hand brake valve.

- If there are air leaks around trailer hand brake valve, replace trailer hand brake valve (page 4-326).
- If there are no air leaks around trailer hand brake valve, notify direct support maintenance.

Table 3-5. Troubleshooting (Cont)

Malfunction	Test or Inspection	Corrective Action
-------------	--------------------	-------------------

BRAKES AND AIR SYSTEM (CONT)

89. AIR SYSTEM HAS NO EFFECT ON BRAKING (HARD BRAKING).

- Step 1. Start engine. Check for low pressure in air tanks by waiting until red warning light goes out or until dual brake gage indicates pressure of 75-106 psi.
- If dual brake gage indicates 75-106 psi, replace air brake booster (page 4-295).
 - If dual brake gage indicates less than 75-106 psi, go to step 2.
- Step 2. Stop engine. Check for leaks in air system by observing brake fluid reservoir air pressure indicator. If reservoir pressure drops suddenly, there are leaks in air system.
- If there are leaks in air system, tighten or replace loose lines or connectors (pages 4-302, 4-303, 4-304, 4-307, 4-310, 4-313, 4-315, 4-318, 4-320, 4-324, 4-327, 4-329, 4-333). If problem continues, notify direct support maintenance.
 - If there are no leaks in air system, go to step 3.
- Step 3. Check fluid regulating valve adjustment as follows:

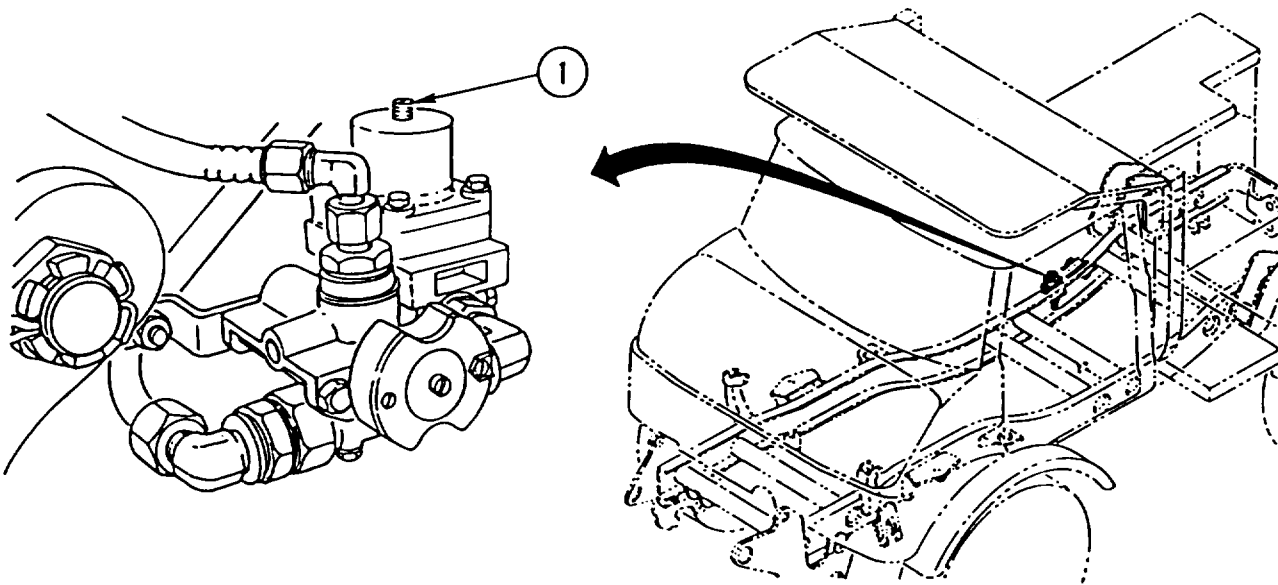

Table 3-5. Troubleshooting (Cont)

Malfunction	Test or Inspection	Corrective Action
-------------	--------------------	-------------------

BRAKES AND AIR SYSTEM (CONT)

NOTE

When fluid regulating valve reaches cut-out pressure, there will be an audible "pop."

- a. Start and run engine at idle until fluid regulating valve reaches cut-out pressure.
- b. Read pressure on dual brake gage. Reading must be approximately 106 psi.
 - If reading is not approximately 106 psi, turn fluid regulating valve adjusting screw (1) 1/4-turn to right to increase pressure, or 1/4-turn to left to decrease pressure. Relieve air pressure (page 2-23) from air tanks to approximately 80 psi and repeat steps a and b until cut-out pressure is approximately 106 psi. If correct cut-out pressure cannot be attained, replace fluid regulating valve (page 4-306).
 - If problem continues, notify direct support maintenance.

STEERING

90. STEERING WHEEL HARD TO MOVE FULL RIGHT AND FULL LEFT.

Step 1. Check for low oil level in power steering tank.

- If oil level is low, add oil (LO 5-2420-224-12).
- If oil level is not low, go to step 2.

Step 2. Check for loose and damaged V-belt on power steering pump.

- If V-belt is loose or damaged, tighten or replace V-belt (page 4-356).
- If V-belt is not loose or damaged, go to step 3.

Step 3. Check for damaged power steering lines.

- If power steering lines are damaged, replace power steering lines (page 4-357).
- If power steering lines are not damaged, go to step 4.

Step 4. Check for clogged power steering filter element.

- If filter element is clogged, replace filter element (page 4-359).
- If filter element is not clogged, notify direct support maintenance.

Table 3-5. Troubleshooting (Cont)

Malfunction	Test or Inspection	Corrective Action
-------------	--------------------	-------------------

STEERING (CONT)

91. STEERING WHEEL HAS TOO MUCH PLAY.

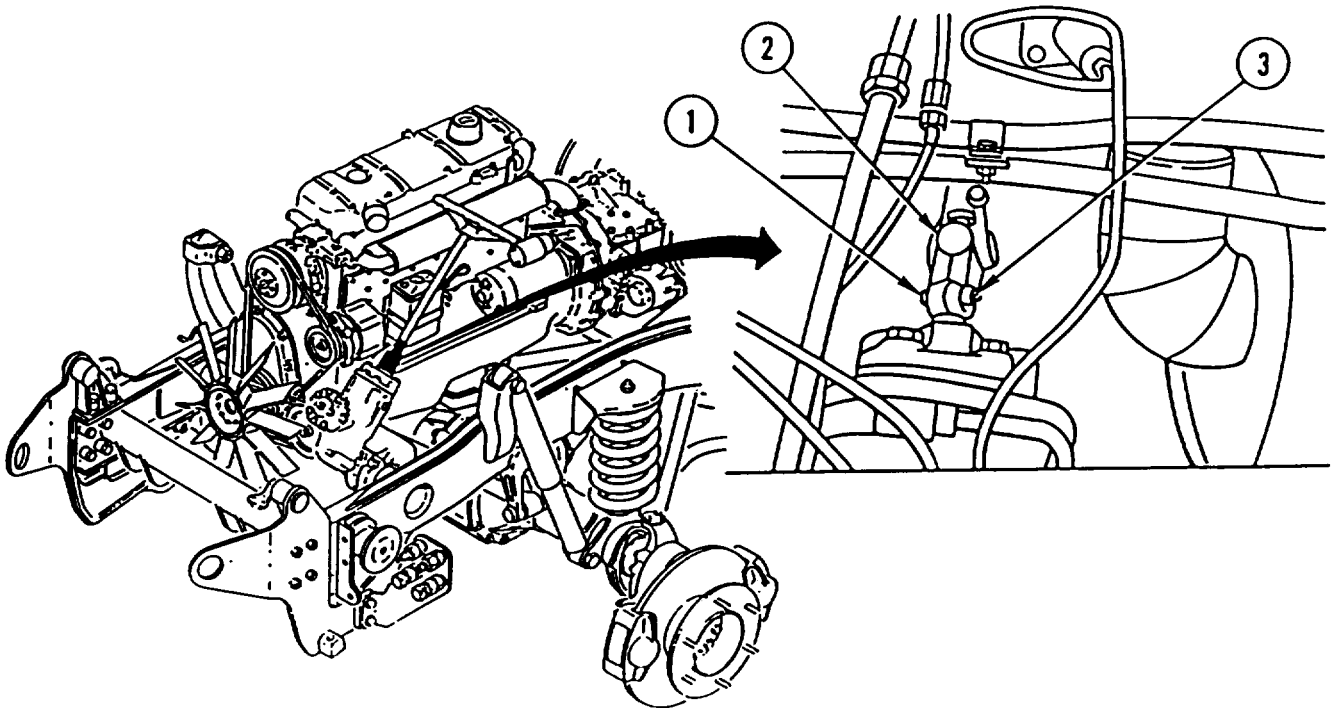

Step 1. Check for loose screw (1) in steering shaft universal joint (2).

- If screw in steering shaft universal joint is loose, tighten fastening nut (3).
- If screw in steering shaft universal joint is not loose, go to step 2.

Step 2. Check for play in drag link and tie rod ball joints.

- If there is play in drag link or tie rod ball joints, replace tie rod or drag link ball joints (pages 4-338, 4-346).
- If there is no play in drag link or tie rod ball joints, go to step 3.

Step 3. Check power steering gear adjustment as follows:

- a. Make sure vehicle is parked on level surface with front wheels straight ahead.

Table 3-5. Troubleshooting (Cont)

Malfunction	Test or Inspection	Corrective Action
-------------	--------------------	-------------------

STEERING (CONT)**NOTE**

Maximum distance of rotation is 0.75 in. (18.75 mm).

- b. Rotate steering wheel left or right until slight resistance is felt.
- If power steering gear is out of adjustment, adjust power steering gear (page 4-354).
 - If problem continues, notify direct support maintenance.

92. STEERING WHEEL VIBRATES AND/OR VEHICLE WANDERS.

Step 1. Check for play in drag link and tie rod ball joints.

- If there is play in drag link or tie rod ball joints, replace tie rod or drag link ball joints (pages 4-338, 4-346).
- If there is no play in drag link or tie rod ball joints, go to step 2.

Step 2. Check for unbalanced wheels.

- If wheels are not properly balanced, balance wheels statically and dynamically.
- If wheels are properly balanced, go to step 3.

Step 3. Check tie rod adjustment.

- If tie rod requires adjustment, adjust tie rod (page 4-341).
- If tie rod does not require adjustment, go to step 4.

Step 4. Check for foam in power steering tank.

- If there is foam in power steering tank, tighten suction line connections and add oil (LO 5-2420-224-12).
- If there is no foam in power steering tank, notify direct support maintenance.

93. POWER STEERING PUMP NOISY.

Step 1. With engine running, check for low oil level in power steering tank.

- If oil level is low, add oil (LO 5-2420-224-12).
- If oil level is not low, go to step 2.

Table 3-5. Troubleshooting (Cont)

Malfunction	Test or Inspection	Corrective Action
-------------	--------------------	-------------------

STEERING (CONT)

Step 2. Check for foam in power steering tank.

- If there is foam in power steering tank, tighten suction line connections and add oil (LO 5-2420-224-12).
- If there is no foam in power steering tank, notify direct support maintenance.

94. POWER STEERING SYSTEM LOSING OIL.

Step 1. Check for loose cover on power steering tank.

- If cover on power steering tank is loose, tighten cover fastenings.
- If cover on power steering tank is tight, go to step 2.

Step 2. Check for leaking and damaged power steering tank, lines, and pump.

- If power steering tank or lines are leaking or damaged, tighten loose connections or replace power steering tank or lines.
- If power steering pump is leaking or damaged, notify direct support maintenance.

SUSPENSION

95. CLUNKING OR CREAKING ON TURNS OR STOPS.

Step 1. Check for loose and bent front axle torsion bar.

- If front axle torsion bar is loose or bent, tighten loose connections or replace front axle torsion bar (page 4-376).
- If front axle torsion bar is not loose or bent, go to step 2.

Step 2. Check for bent front control arm.

- If front control arm is bent, replace front control arm (page 4-374).
- If front control arm is not bent, go to step 3.

Step 3. Check for oil leaking from shock absorbers.

- If shock absorbers are leaking oil, replace shock absorbers (pages 4-368, 4-369, 4-372).
- If shock absorbers are not leaking oil, go to step 4.

Table 3-5. Troubleshooting (Cont)

Malfunction	Test or Inspection	Corrective Action
-------------	--------------------	-------------------

Suspension (CONT)

Step 4. Check for loose front propeller shaft U-joint.

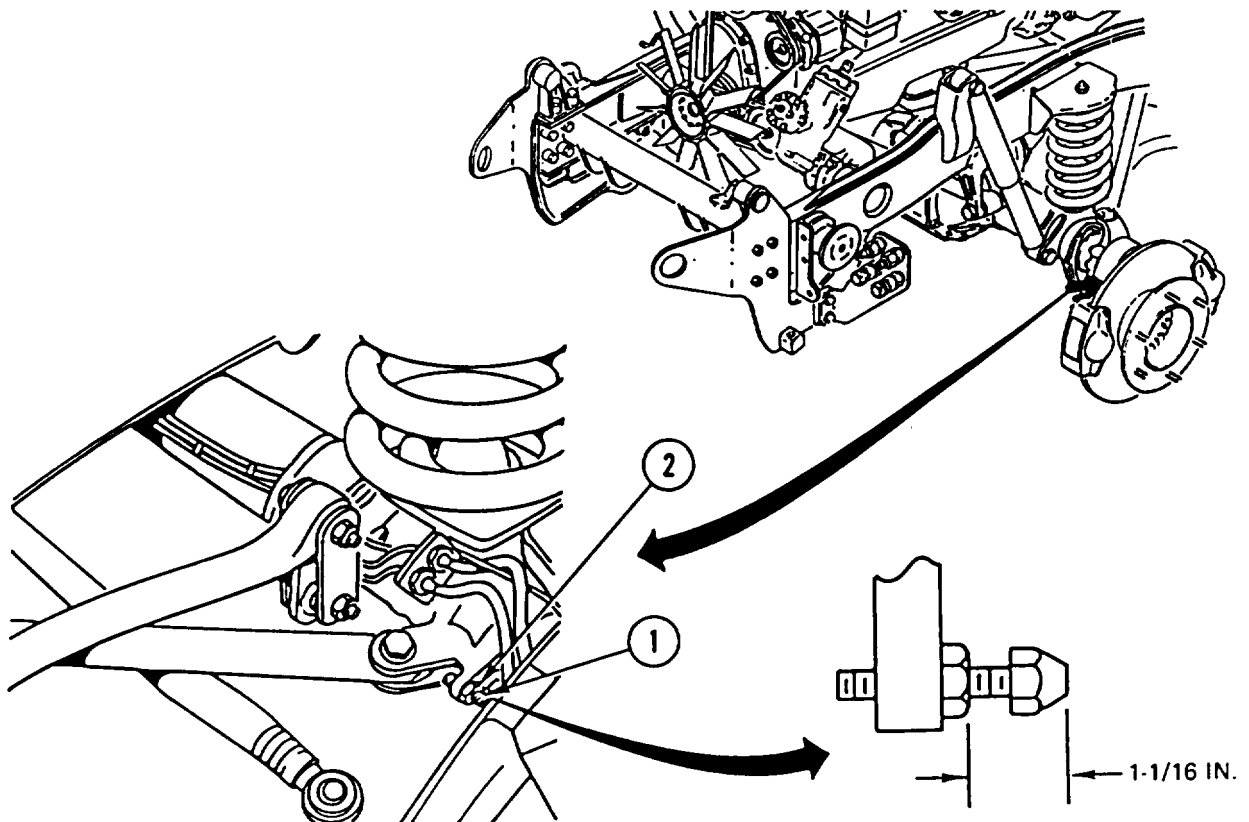

- If front propeller shaft U-joint is not loose, adjust front axle stops as follows:
 - (1) Measure length of stop bolt (1). Length must be 1-1/16 \pm 1/16 in. (27 \pm 1.5 mm). If measurement is not within tolerance, loosen lock nut (2) and adjust stop bolt (1) to required length.
 - (2) Tighten lock nut (2).
- If front propeller shaft U-joint is loose, notify direct support maintenance.

Table 3-5. Troubleshooting (Cont)

Malfunction	Test or Inspection	Corrective Action
-------------	--------------------	-------------------

SUSPENSION (CONT)

96. HYDRAULIC SUSPENSION LOCKOUT SYSTEM WILL NOT ENGAGE (HMMH).

Step 1. Check for low oil level in hydraulic suspension lockout system.

- If oil level is low, add oil (LO 5-2420-224-12).
- If oil level is not low, go to step 2.

Step 2. Check for oil leaks and damaged lines in hydraulic suspension lockout system.

- If there are oil leaks or damaged lines in hydraulic suspension lockout system, tighten loose connections or replace lines (pages 4-650, 4-652).
- If there are no oil leaks or damaged lines in hydraulic suspension lockout system, perform Malfunction 72 or Malfunction 73.

97. ONE SIDE OF HYDRAULIC SUSPENSION LOCKOUT WILL NOT ENGAGE (HMMH).

Check for oil leaks and damaged lines in hydraulic suspension lockout system.

- If there are no oil leaks or damaged lines in hydraulic suspension lockout system, tighten loose connections or replace lines (pages 4-650, 4-652).
- If there are oil leaks or damaged lines in hydraulic suspension lockout system, replace front shock absorbers (page 4-369).

HYDRAULIC SYSTEM

98. HYDRAULIC PUMP NOISY.

NOTE

Steps 1 thru 3 are the same for both front and rear hydraulic pumps.

Step 1. Check for loose mounting capscrews on hydraulic pump.

- If mounting capscrews are loose, tighten capscrews.
- If mounting capscrews are tight, go to step 2.

Step 2. Check for low oil level in hydraulic tank.

- If oil level is low, add oil (LO 5-2420-224-12).
- If oil level is not low, go to step 3.

Table 3-5. Troubleshooting (Cont)

Malfunction	Test or Inspection	Corrective Action
-------------	--------------------	-------------------

HYDRAULIC SYSTEM (CONT)

Step 3. Check for loose and damaged hydraulic pump lines.

- If hydraulic pump lines are loose or damaged, tighten loose connections or replace hydraulic pump lines (pages 4-584, 4-590). If problem continues, notify direct support maintenance.
- If hydraulic pump lines are not loose or damaged, replace hydraulic tank filter (pages 4-709, 4-720).

99. HYDRAULIC OIL FOAMY (FRONT LOADER/FORKLIFT, BACKHOE/CRANE, AND HYDRAULIC TOOLS OPERATE ERRATICALLY).

Step 1. Check for low oil level in front or rear hydraulic tank.

- If oil level is low, add oil (LO 5-2420-224-12).
- If oil level is not low, go to step 2.

Step 2. Check for water in hydraulic oil.

- If there is water in hydraulic oil, replace hydraulic oil (LO 5-2420-224-12) and make sure fill caps are tight.
- If there is no water in hydraulic oil, go to step 3.

Step 3. Check for loose and damaged hydraulic pump lines.

- If hydraulic pump lines are not loose or damaged, replace front or rear hydraulic tank filter (pages 4-709, 4-720).
- If hydraulic pump lines are loose or damaged, tighten loose connections or replace hydraulic pump lines (pages 4-584, 4-590). If problem continues, notify direct support maintenance.

100. HYDRAULIC OIL OVERHEATS.

Step 1. Check for low oil level in front or rear hydraulic tank.

- If oil level is low, add oil (LO 5-2420-224-12).
- If oil level is not low, go to step 2.

Step 2. Check fan shroud for debris that could block air flow.

- If there is debris in fan shroud, remove debris.
- If there is no debris in fan shroud, perform Malfunction 74.

Table 3-5. Troubleshooting (Cont)

Malfunction	Test or Inspection	Corrective Action
-------------	--------------------	-------------------

FORKLIFT (HMMH)

101. FORKLIFT WILL NOT MOVE (EMPTY).

Step 1. Check installation of quick-disconnect connectors.

- If quick-disconnect connectors are not properly installed, install quick-disconnect connectors properly.
- If quick-disconnect connectors are properly installed, go to step 2.

Step 2. Check for low oil level in front hydraulic tank.

- If oil level is low, add oil (LO 5-2420-224-12).
- If oil level is not low, go to step 3.

Step 3. Check for damaged lift cylinder inlet line.

- If lift cylinder inlet line is damaged, replace inlet line (page 4-628).
- If lift cylinder inlet line is not damaged, notify direct support maintenance.

102. FORKLIFT WILL NOT LIFT LOAD.

Check for improperly lubricated mast channels.

- If mast channels are not properly lubricated, lubricate mast channels (LO 5-2420-224-12).
- If mast channels are properly lubricated, notify direct support maintenance

103. LIFT CYLINDER DRIFTS DOWN.

Check hydraulic supply lines for loose and damaged connectors.

- If connectors are loose or damaged, tighten loose connectors or replace hydraulic supply lines (page 4-628).
- If connectors are not loose or damaged, notify direct support maintenance.

Table 3-5. Troubleshooting (Cont)

Malfunction	Test or Inspection	Corrective Action
-------------	--------------------	-------------------

FORKLIFT (HMMH) (CONT)

104. MASTER PLUNGER DRIFTS UP WHEN LOAD LIFTED, THEN STOPS.

Check for low oil level in front hydraulic tank.

- If oil level is low, add oil (LO 5-2420-224-12).
- If oil level is not low, bleed lift cylinder (page 4-630).

105. TILT CYLINDER DRIFTS.

NOTE

Steps 1 and 2 are the same for both tilt cylinders.

Step 1. Check for loose and damaged hydraulic lines.

- If hydraulic lines are loose or damaged, tighten loose connections or replace hydraulic lines (page 4-620).
- If hydraulic lines are not loose or damaged, go to step 2.

Step 2. Check for damaged tilt cylinder packings as follows:

- a. Start engine.
- b. Tilt forklift forward until forklift stops moving. Stop engine.

Table 3-5. Troubleshooting (Cont)

Malfunction	Test or Inspection	Corrective Action
-------------	--------------------	-------------------

FORKLIFT (HMMH) (CONT)

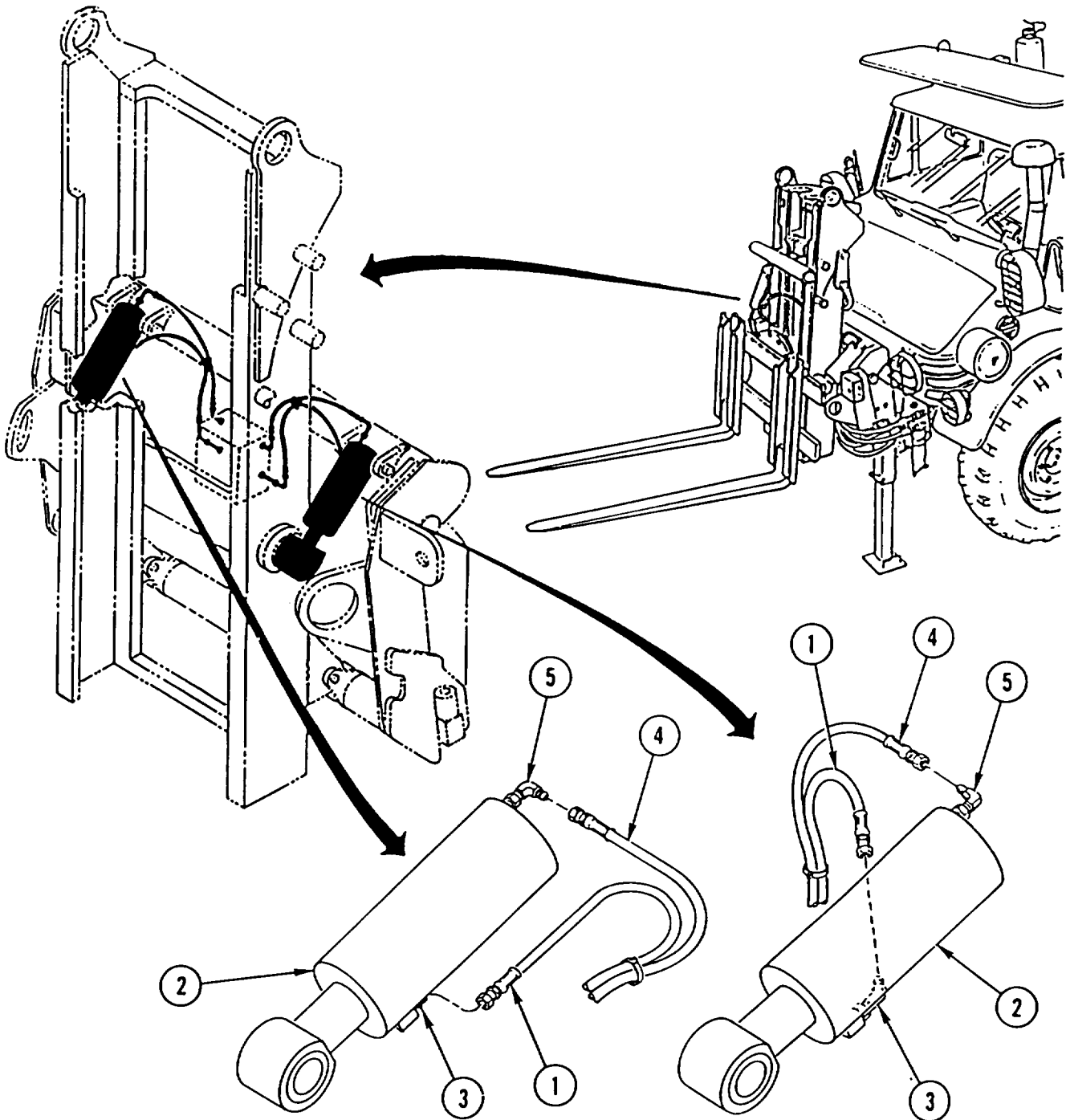

Table 3-5. Troubleshooting (Cont)

Malfunction	Test or Inspection	Corrective Action
-------------	--------------------	-------------------

FORKLIFT (HMMH) (CONT)**NOTE**

Use threaded plugs in hoses in steps c and g. Failure to do so will result in spilled hydraulic oil.

- c. Disconnect hose (1) at rod end of tilt cylinder (2) and install threaded plug. Start and run engine at idle.

NOTE

During steps d and h, there may be a small amount of hydraulic oil leaking, either drops or a small stream the diameter of a pencil lead. This is normal. Use drip pan to catch oil.

- d. Move forklift control lever to tilt forward position. Hold lever in tilt forward position and have assistant check for leaks from fitting (3) at rod end of tilt cylinder (2).
 - If there is excessive leakage from fitting, replace tilt cylinder (page 4-686).
 - If there is not excessive leakage from fitting, go to step e..
- e. Stop engine. Remove threaded plug and connect hose (1) at rod end of tilt cylinder (2).
- f. Start and run engine at idle. Move forklift control lever to tilt back position.
- g. Stop engine. Disconnect hose (4) at cylinder end of tilt cylinder (2) and install threaded plug.
- h. Start and run engine at idle. Move forklift control lever to tilt back position. Hold lever in tilt back position and have assistant check for leaks from fitting (5) at cylinder end of tilt cylinder (2).
 - If there is excessive leakage from fitting, replace tilt cylinder (page 4-686).
 - If there is not excessive leakage from fitting, notify direct support maintenance.

106. ROTATOR CYLINDER DRIFTS.

Step 1. Check for loose and damaged hydraulic lines.

- If hydraulic lines are loose or damaged, tighten loose connections or replace hydraulic lines (page 4-624).
- If hydraulic lines are not loose or damaged, go to step 2.

Step 2. Check for damaged rotator cylinder packings as follows:

- a. Start engine.
- b. Rotate forklift to right until forklift stops moving. Stop engine.

Table 3-5. Troubleshooting (Cont)

Malfunction	Test or Inspection	Corrective Action
-------------	--------------------	-------------------

FORKLIFT (HMMH) (CONT)

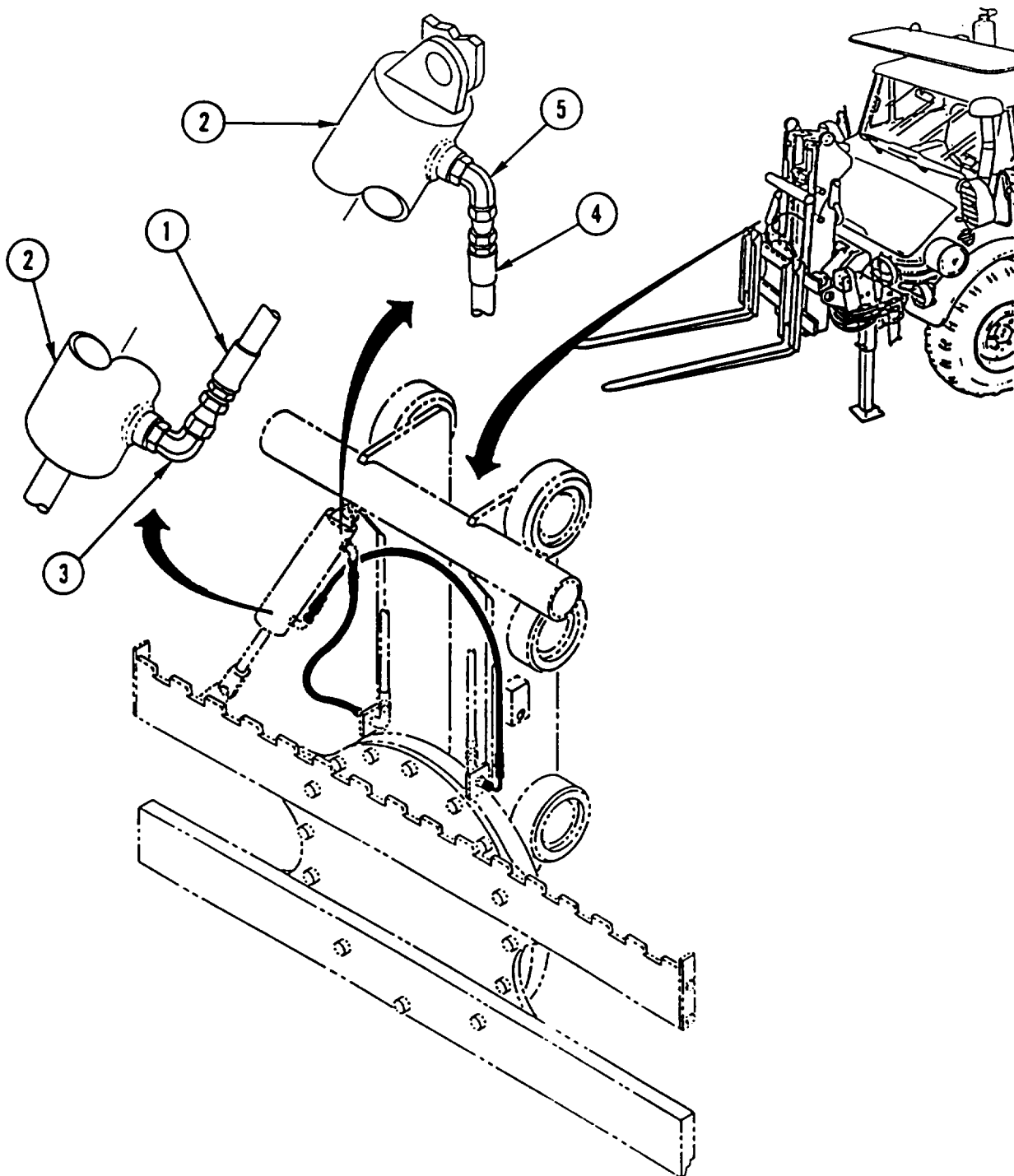

Table 3-5. Troubleshooting (Cont)

Malfunction	Test or Inspection	Corrective Action
-------------	--------------------	-------------------

FORKLIFT (HMMH) (CONT)

NOTE

Use threaded plugs in hoses for steps c and g. Failure to do so will result in spilled hydraulic oil.

- c. Disconnect hose (1) at rod end of rotator cylinder (2) and install threaded plug. Start and run engine at idle.

NOTE

During steps d and h, there may be a small amount of hydraulic oil leaking, either drops or a small stream the diameter of a pencil lead. This is normal. Use drip pan to catch oil.

- d. Move forklift control lever to rotate right position. Hold lever in rotate right position and have assistant check for leaks from fitting (3) at rod end of rotator cylinder (2).
 - If there is excessive leakage from fitting, replace rotator cylinder (page 4-688).
 - If there is not excessive leakage from fitting, go to step e.
- e. Stop engine. Remove threaded plug and connect hose (1) at rod end of rotator cylinder (2).
- f. Start and run engine at idle. Move forklift control lever to rotate left position.
- g. Stop engine. Disconnect hose (4) at cylinder end of rotator cylinder (2) and install threaded plug.
- h. Start and run engine at idle. Move forklift control lever to rotate left position. Hold lever in rotate left position and have assistant check for leaks from fitting (5) at cylinder end of rotator cylinder (2).
 - If there is excessive leakage from fitting, replace rotator cylinder (page 4-688).
 - If there is not excessive leakage from fitting, notify direct support maintenance.

Table 3-5. Troubleshooting (Cont)

Malfunction	Test or Inspection	Corrective Action
-------------	--------------------	-------------------

FORKLIFT (HMMH) (CONT)

107. FORKLIFT TILTS WITH ROTATE BUTTON DEPRESSED.

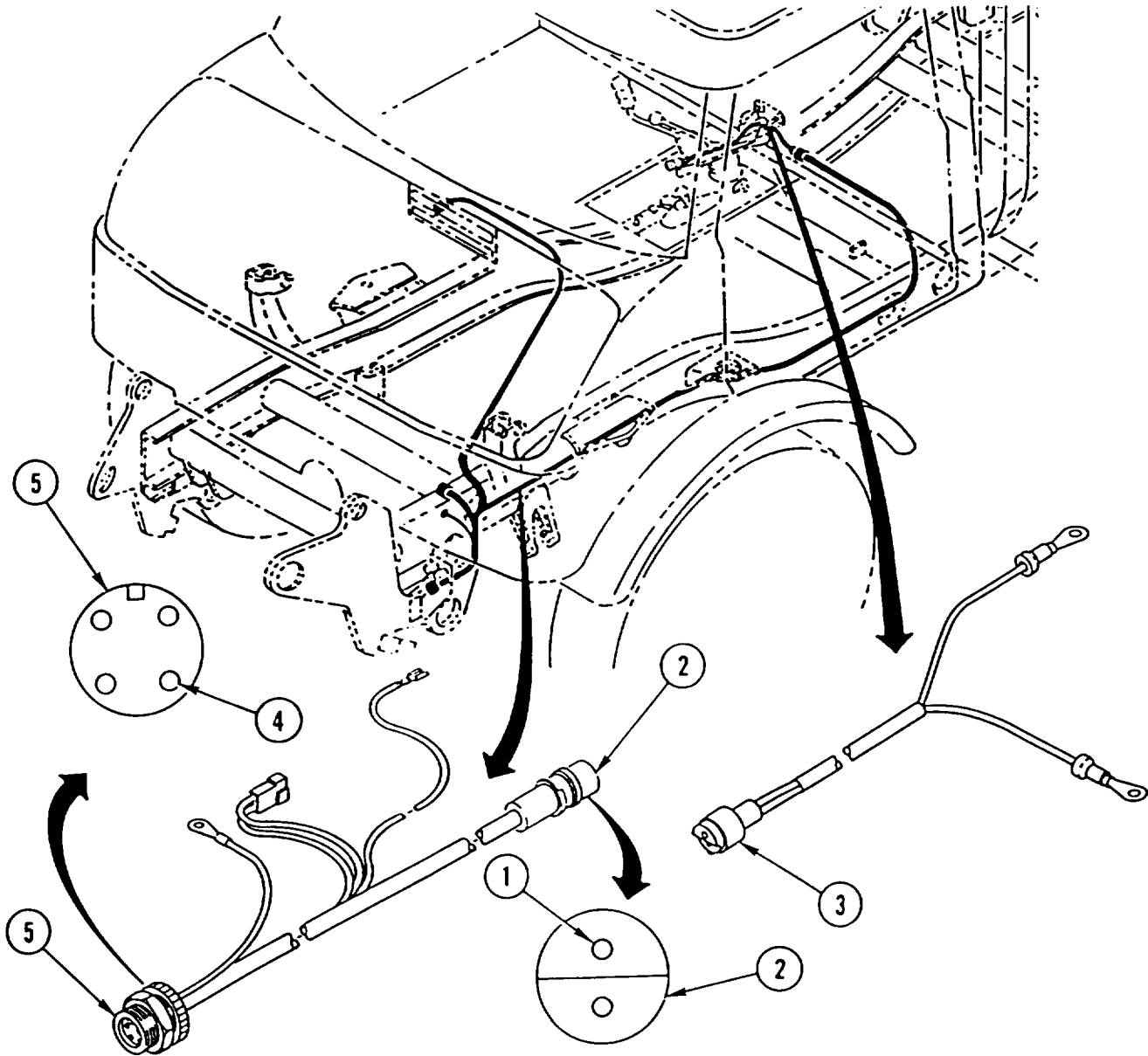

Table 3-5. Troubleshooting (Cont)

Malfunction	Test or Inspection	Corrective Action
-------------	--------------------	-------------------

FORKLIFT (HMMH) (CONT)

Step 1. Check for +24 VDC between pin 1 (1) and ground at connector (2).

- If +24 VDC is not present, repair wiring between connector (2) and fuse box 1.
- If +24 VDC is present, go to step 2.

Step 2. Check for continuity to ground between pins of connector (3).

- If open to ground, repair wiring harness.
- If short to ground, go to step 3.

Step 3. Check for +24 VDC between pin 3 (4) and ground at forklift connector (5) with rotate button pushed.

- If +24 VDC is not present, repair wiring between connector (2) and forklift connector.
- If +24 VDC is present, go to step 4.

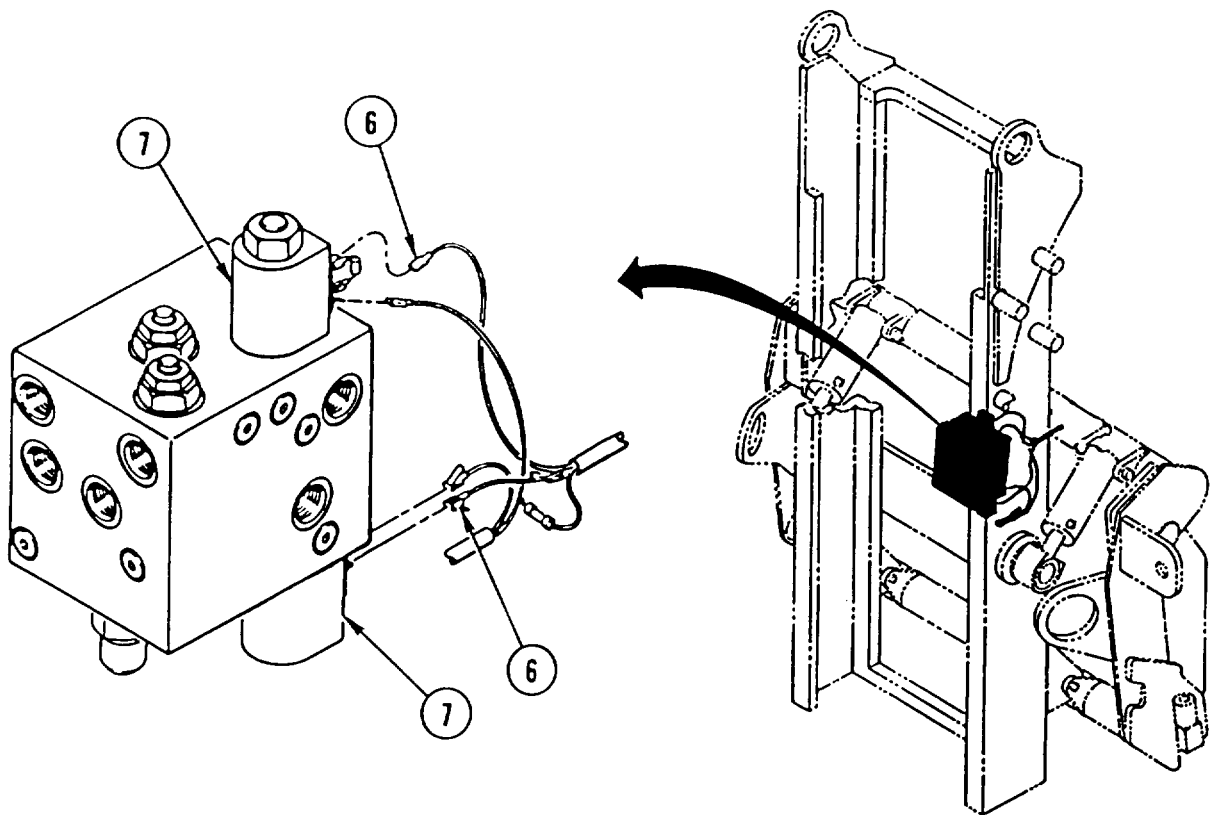

Table 3-5. Troubleshooting (Cont)

Malfunction	Test or Inspection	Corrective Action
-------------	--------------------	-------------------

FORKLIFT (HMMH) (CONT)

Step 4. Check for +24 VDC between wire (6) and ground at forklift rotator solenoids (7) with rotate button pushed.

- If +24 VDC is present, notify direct support maintenance.
- If +24 VDC is not present, repair wiring between forklift rotator solenoids and forklift connector.

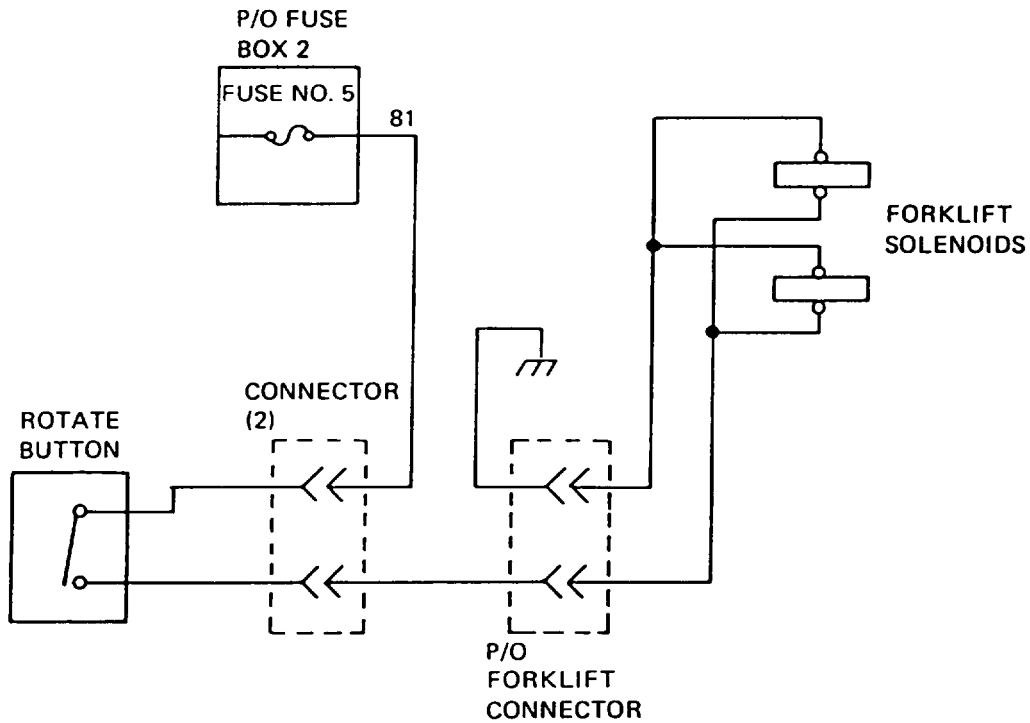

HD45 HAMMER DRILL (SEE)

108. HAMMER DRILL WILL NOT OPERATE.

Attempt to operate a different hydraulic tool.

- If alternate tool operates, replace hammer drill.
- if alternate tool does not operate, perform Malfunction 76.

Table 3-5. Troubleshooting (Cont)

Malfunction	Test or Inspection	Corrective Action
-------------	--------------------	-------------------

HD45 HAMMER DRILL (SEE) (CONT)

109. HAMMER DRILL OVERHEATS.

Check for low oil level in rear hydraulic tank.

- If oil level is low, add oil (LO 5-2420-224-12).
- If oil level is not low, perform Malfunction 100.

110. HAMMER DRILL OPERATES SLOWLY OR INEFFECTIVELY.

Step 1. Check for damaged hydraulic lines.

- If hydraulic lines are damaged, replace hydraulic lines (page 4-586).
- If hydraulic lines are not damaged, go to step 2.

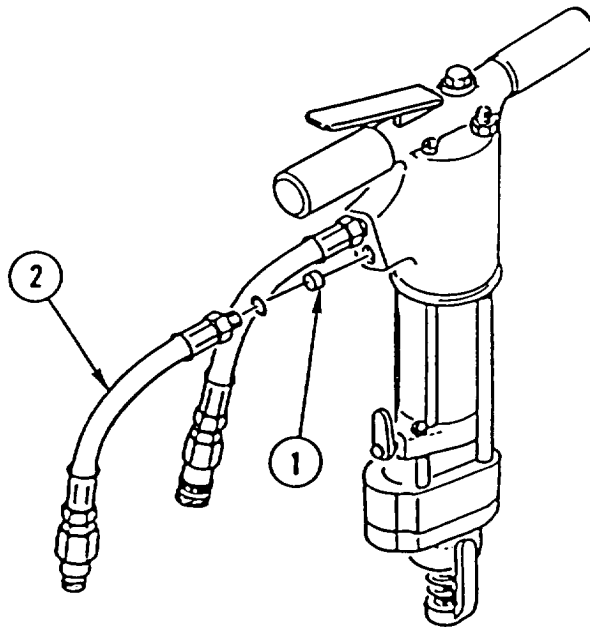

Step 2. Check for blocked plug (1) by removing hose (2) and plug and checking for foreign matter.

- If plug is blocked, remove foreign matter.
- If plug is not blocked, install plug and hose and go to step 3.

Step 3. Attempt to operate a different hydraulic tool.

- If alternate tool operates at normal speed, replace hammer drill.
- If alternate tool does not operate at normal speed, notify direct support maintenance.

Table 3-5. Troubleshooting (Cont)

Malfunction	Test or Inspection	Corrective Action
-------------	--------------------	-------------------

IMPACT WRENCH (HMMH)

111. IMPACT WRENCH PERFORMS POORLY OR HAS LOW IMPACT.

Step 1. Check for damaged hydraulic lines.

- If hydraulic lines are damaged, replace hydraulic lines (page 4-586).
- If hydraulic lines are not damaged, go to step 2.

Step 2. Check for low engine speed by pulling hydraulic tool switch out and checking engine rpm on tachometer. Engine speed should be 2000 rpm.

- If engine speed is not 2000 rpm, adjust air cylinder (page 4-77).
- If engine speed is 2000 rpm, notify direct support maintenance.

112. IMPACT WRENCH OVERHEATS.

Check for low oil level in rear hydraulic tank.

- If oil level is low, add oil (LO 5-2420-224-12).
- If oil level is not low, perform Malfunction 100.

113. OIL LEAKS AT HAMMER CASE.

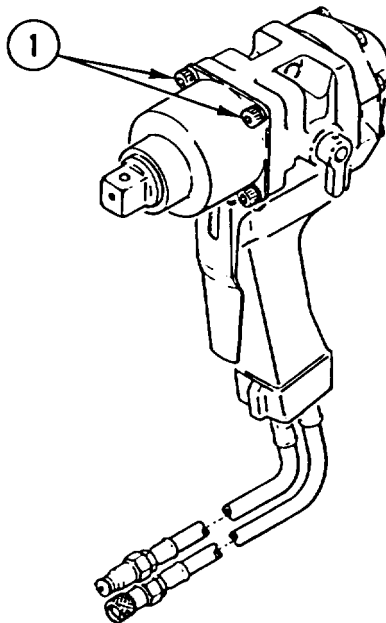

Table 3-5. Troubleshooting (Cont)

Malfunction	Test or Inspection	Corrective Action
-------------	--------------------	-------------------

IMPACT WRENCH (HMMH) (CONT)

Check for loose hammer case socket head capscrews (1).

- If hammer case socket head capscrews are loose, tighten capscrews to 13-15 lb-ft (17.6-18.3 N.m).
- If hammer case socket head capscrews are tight, notify direct support maintenance.

114. IMPACT WRENCH WILL NOT OPERATE.

Check for damaged hose couplers.

- If hose couplers are damaged, repair tool hose couplers (page 4-471).
- If hose couplers are not damaged, perform Malfunction 76.

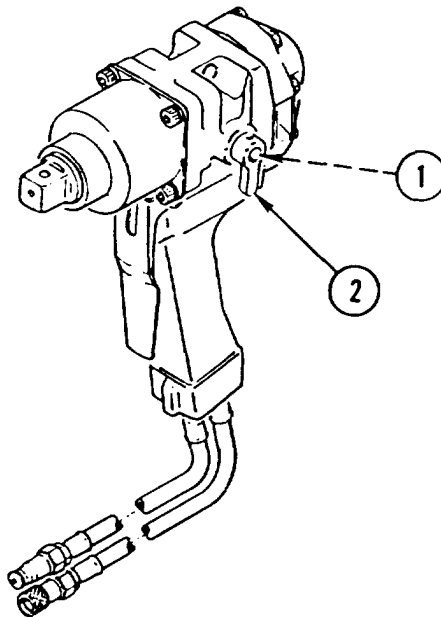
115. IMPACT WRENCH WILL NOT OPERATE IN ONE DIRECTION ONLY.

Check for loose and missing setscrew (1) in directional control lever (2).

- If setscrew in directional control lever is loose or missing, tighten or replace setscrew.
- If setscrew in directional control lever is not loose or missing, notify direct support maintenance.

Table 3-5. Troubleshooting (Cont)

Malfunction	Test or Inspection	Corrective Action
-------------	--------------------	-------------------

BR67 PAVEMENT BREAKER (SEE)

116. PAVEMENT BREAKER WILL NOT OPERATE.

Step 1. Check for damaged hydraulic lines.

- If hydraulic lines are damaged, replace hydraulic lines (page 4-586).
- If hydraulic lines are not damaged, go to step 2.

Step 2. Attempt to operate a different hydraulic tool.

- If alternate tool operates, replace pavement breaker.
- If alternate tool does not operate, perform Malfunction 76.

117. PAVEMENT BREAKER WILL NOT OPERATE EFFECTIVELY.

Check for damaged hydraulic lines.

- If hydraulic lines are damaged, replace hydraulic lines (page 4-586).
- If hydraulic lines are not damaged, notify direct support maintenance.

118. PAVEMENT BREAKER OVERHEATS.

Step 1. Check for low oil level in rear hydraulic tank.

- If oil level is low, add oil (LO 5-2420-224-12).
- If oil level is not low, perform Malfunction 100.

CHAIN SAW (SEE)

119. CHAIN SAW WILL NOT OPERATE.

Step 1. Check for leaking and damaged hydraulic lines.

- If hydraulic lines are leaking or damaged, tighten loose connections or replace hydraulic lines (page 4-586).
- If hydraulic lines are not leaking or damaged, go to step 2.

Step 2. Attempt to operate a different hydraulic tool.

- If alternate tool operates, replace chain saw.
- If alternate tool does not operate, perform Malfunction 76.

120. CHAIN SAW CUTS SLOWLY OR NOT AT ALL.

Check for worn and damaged chain.

- If chain is worn or damaged, replace chain saw chain (page 4-744).
- If chain is not worn or damaged, notify direct support maintenance.

Table 3-5. Troubleshooting (Cont)

Malfunction	Test or Inspection	corrective Action
-------------	--------------------	-------------------

CHAIN SAW (SEE) (CONT)

121. BAR TURNS COLOR.

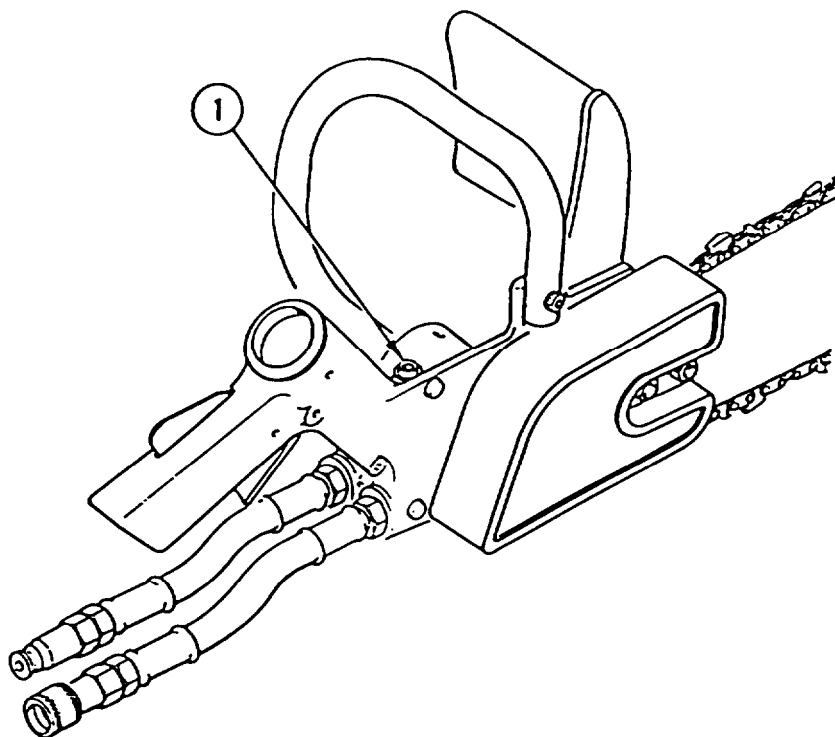

Step 1. Check for proper automatic chain oiler (1) operation by operating chain saw and checking for oil delivery from chain oiler.

- If automatic chain oiler is not operating properly, adjust chain oiler by turning counterclockwise to increase oil flow.
- If automatic chain oiler is operating properly, go to step 2.

Step 2. Check for worn and damaged chain.

- If chain is worn or damaged, replace chain saw chain (page 4-744).
- If chain is not worn or damaged, adjust chain saw chain tension (TM 5-2420-224-10).

122. CHAIN SAW OVERHEATS.

Check for low oil level in rear hydraulic tank.

- If oil level is low, add oil (LO 5-2420-224-12).
- If oil level is not low, perform Malfunction 100.

Table 3-5. Troubleshooting (Cont)

Malfunction	Test or Inspection	Corrective Action
-------------	--------------------	-------------------

BACKHOE (SEE)

123. ALL BACKHOE FUNCTIONS SLUGGISH.

Step 1. Check for loose and damaged hydraulic lines.

- If hydraulic lines are loose or damaged, tighten loose connections or replace hydraulic lines (pages 4-590, 4-592, 4-594, 4-596, 4-598, 4-600, 4-602, 4-604, 4-606, 4-608, 4-610, 4-612, 4-614, 4-616, 4-618).
- If hydraulic lines are not loose or damaged, go to step 2.

Step 2. Check engine rpm on tachometer. Engine speed should be 2000 rpm.

- If engine speed is not 2000 rpm, adjust air cylinder (page 4-76).
- If engine speed is 2000 rpm, notify direct support maintenance.

124. BOOM CYLINDER DRIFTS.

NOTE

Steps 1 and 2 are the same for both boom cylinders.

Step 1. Check for loose and damaged hydraulic lines.

- If hydraulic lines are loose or damaged, tighten loose connections or replace hydraulic lines (page 4-610).
- If hydraulic lines are not loose or damaged, go to step 2.

Step 2. Check for damaged boom cylinder packing as follows:

- a. Start engine.

Table 3-5. Troubleshooting (Cont)

Malfunction	Test or Inspection	Corrective Action
-------------	--------------------	-------------------

BACKHOE (SEE) (CONT)

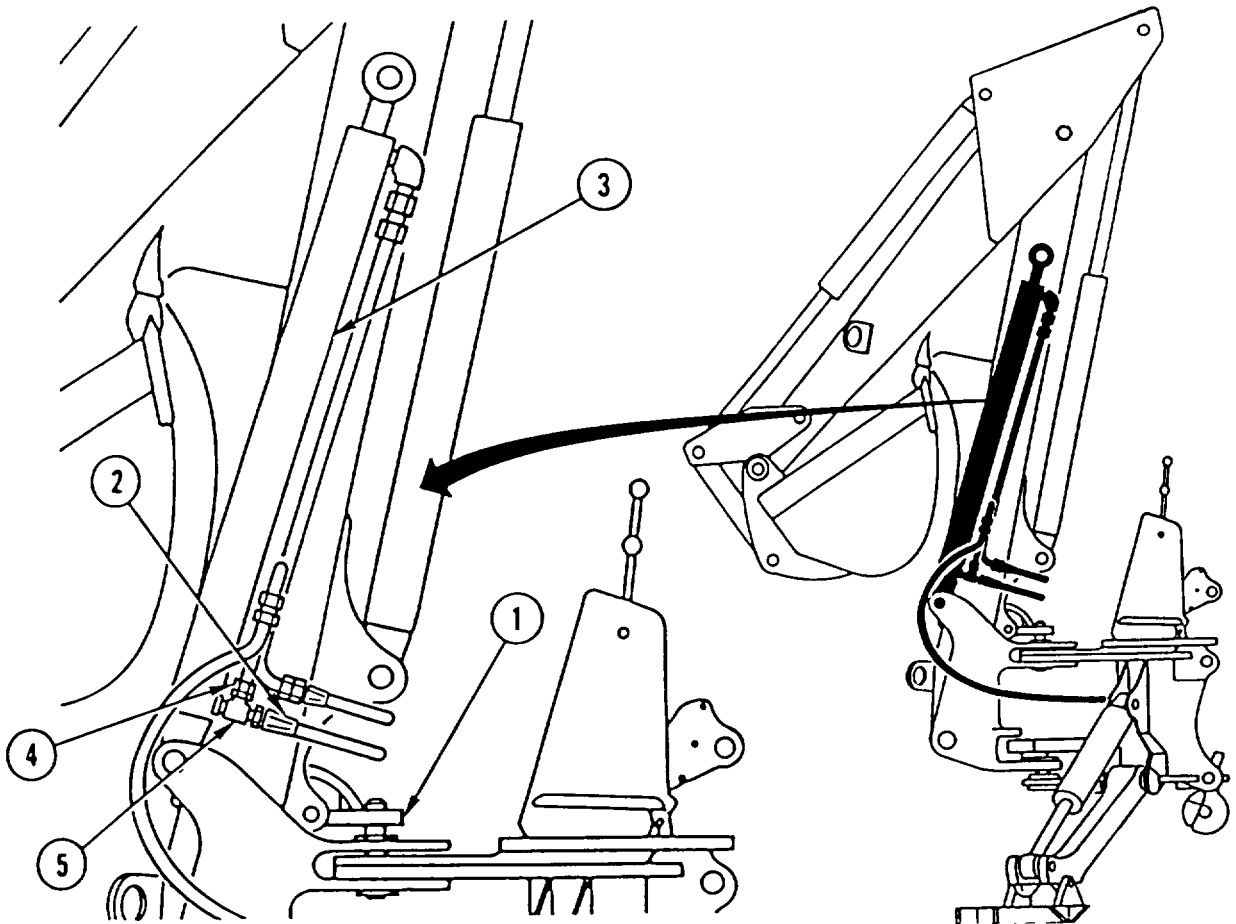

- b. Place boom in position illustrated and engage backhoe boom latch (1). Stop engine.

NOTE

Use threaded plug in tube. Failure to do so will result in spilled hydraulic oil.

- c. Remove hose (2) from cylinder end of boom cylinder (3). Disconnect tube (4) from fitting (5) and install threaded plug.
- d. Start engine. Set engine RPM switch to HI.

Table 3-5. Troubleshooting (Cont)

Malfunction

Test or Inspection

Corrective Action

BACKHOE (SEE) (CONT)

NOTE

During step e, there may be a small amount of hydraulic oil leaking, either drops or a small stream the diameter of a pencil lead. This is normal. Use drip pan to catch oil.

- e. Pull boom control lever and check for leaks from boom cylinder (3).
 - If there is excessive leakage from boom cylinder, replace boom cylinder (page 4-658).
 - If there is not excessive leakage from boom cylinder, notify direct support maintenance.

125. BUCKET CYLINDER DRIFTS.

Step 1. Check for loose and damaged hydraulic lines.

- If hydraulic lines are loose or damaged, tighten loose connections or replace hydraulic lines (page 4-616).
- If hydraulic lines are not loose or damaged, go to step 2.

Step 2. Check for damaged bucket cylinder packing as follows:

- a. Start engine. Pull boom control lever inward until bucket is above floor.
- b. Pull bucket control lever inward until bucket stops moving.
- c. Push boom control lever outward until bucket is on floor. Stop engine.

Table 3-5. Troubleshooting (Cont)

Malfunction	Test or Inspection	Corrective Action
-------------	--------------------	-------------------

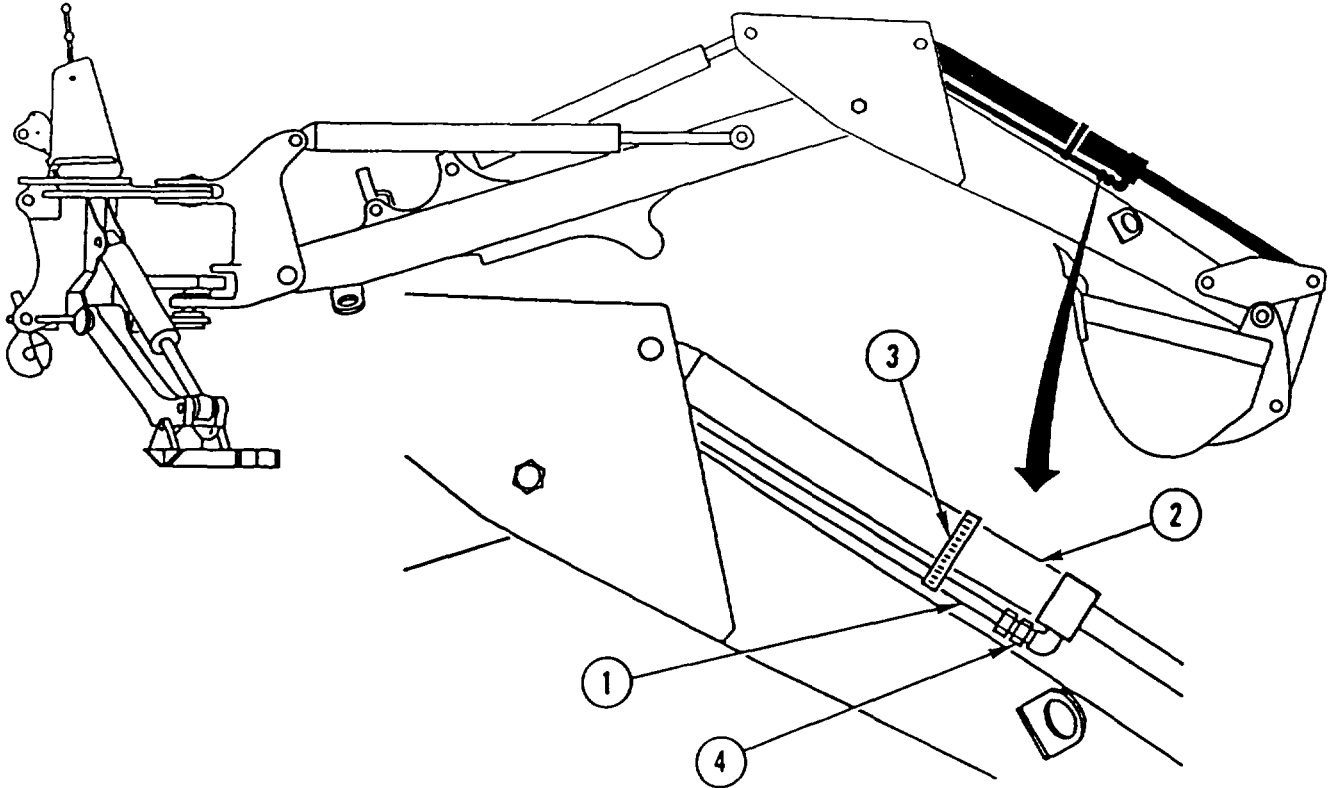
BACKHOE (SEE) (CONT)**NOTE**

Use threaded plug in tube. Failure to do so will result in spilled hydraulic oil.

- d. Disconnect tube (1) from rod end of bucket cylinder (2) and loosen clamp (3) holding tube (1). Move tube away from fitting (4) and install threaded plug.
- e. Start engine. Set engine RPM switch to HI.

NOTE

During step f, there may be a small amount of hydraulic oil leaking, either drops or a small stream the diameter of a pencil lead. This is normal. Use drip pan to catch oil.

- f. Pull bucket control lever inward and check for leaks from fitting (4).
 - If there is excessive leakage from fitting, replace bucket cylinder (page 4-668).
 - If there is not excessive leakage from fitting, notify direct support maintenance.

Table 3-5. Troubleshooting (Cont)

Malfunction	Test or Inspection	Corrective Action
-------------	--------------------	-------------------

BACKHOE (SEE) (CONT)

126. DIPPER CYLINDER DRIFTS.

Step 1. Check for loose and damaged hydraulic lines.

- If hydraulic lines are loose or damaged, tighten loose connections or replace hydraulic lines (page 4-614).
- If hydraulic lines are not loose or damaged, go to step 2.

Step 2. Check for damaged dipper cylinder packing as follows:

- Start engine. Place backhoe in transport position.
- Pull dipper control lever inward to move dipper against boom until dipper stops moving. Stop engine.

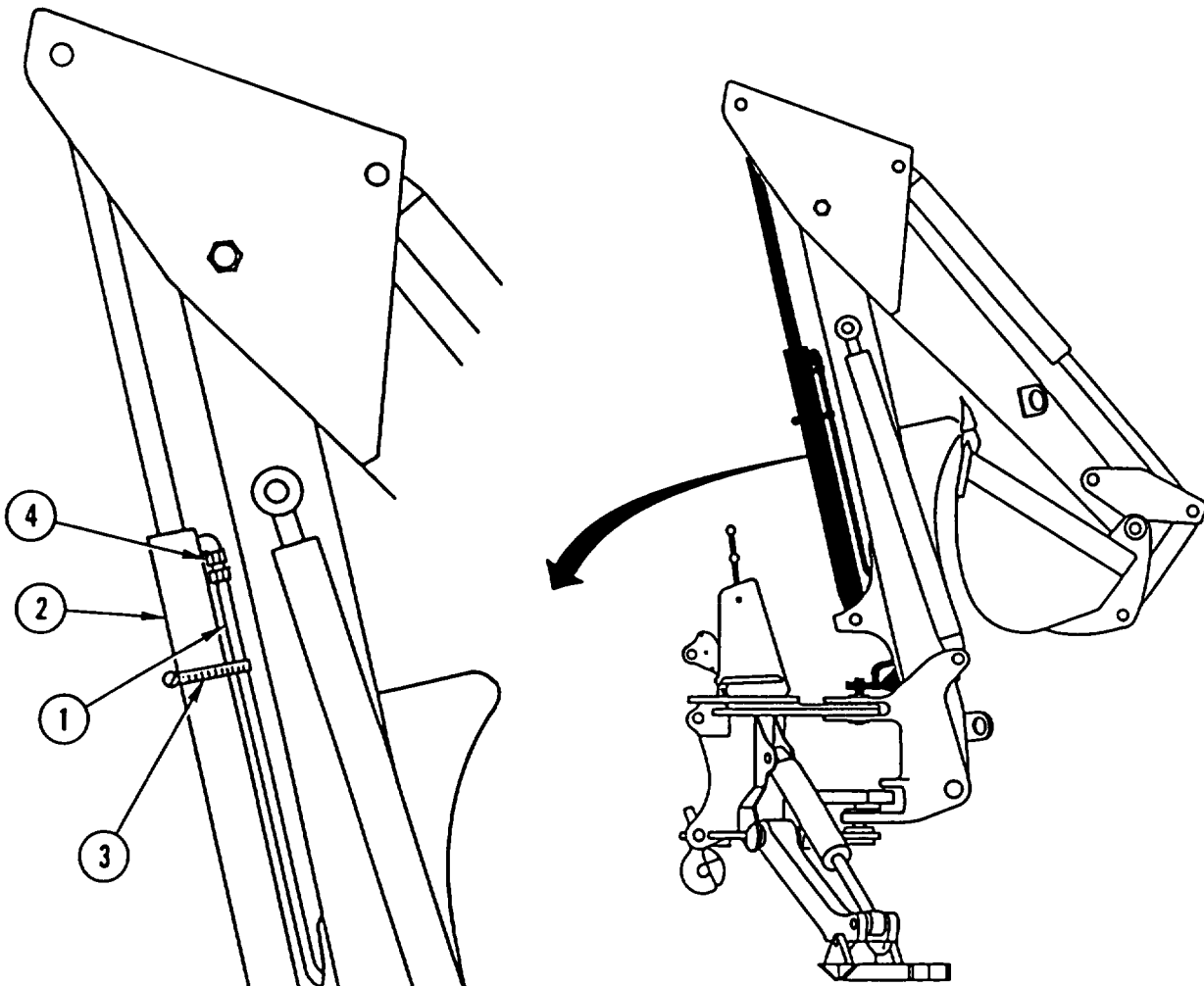

Table 3-5. Troubleshooting (Cont)

Malfunction	Test or Inspection	Corrective Action
-------------	--------------------	-------------------

BACKHOE (SEE) (CONT)**NOTE**

Use threaded plug in tube. Failure to do so will result in spilled hydraulic oil.

- c. Disconnect tube (1) from rod end of dipper cylinder (2) and loosen clamp (3) holding tube (1). Move tube away from fitting (4) and install threaded plug.
- d. Start engine. Set engine RPM switch to HI.

NOTE

During step e, there may be a small amount of hydraulic oil leaking, either drops or a small stream the diameter of a pencil lead. This is normal. Use drip pan to catch oil.

- e. Pull dipper control lever inward and check for leaks from fitting (4).
 - If there is excessive leakage from fitting, replace dipper cylinder (page 4-670).
 - If there is not excessive leakage from fitting, notify direct support maintenance.

127. SWING CYLINDER DRIFTS.**NOTE**

Steps 1 and 2 are the same for both swing cylinders.

Step 1. Check for loose and damaged hydraulic lines.

- If hydraulic lines are loose or damaged, tighten loose connections or replace hydraulic lines (page 4-606).
- If hydraulic lines are not loose or damaged, go to step 2.

Table 3-5. Troubleshooting (Cont)

Malfunction	Test or Inspection	Corrective Action
-------------	--------------------	-------------------

BACKHOE (SEE) (CONT)

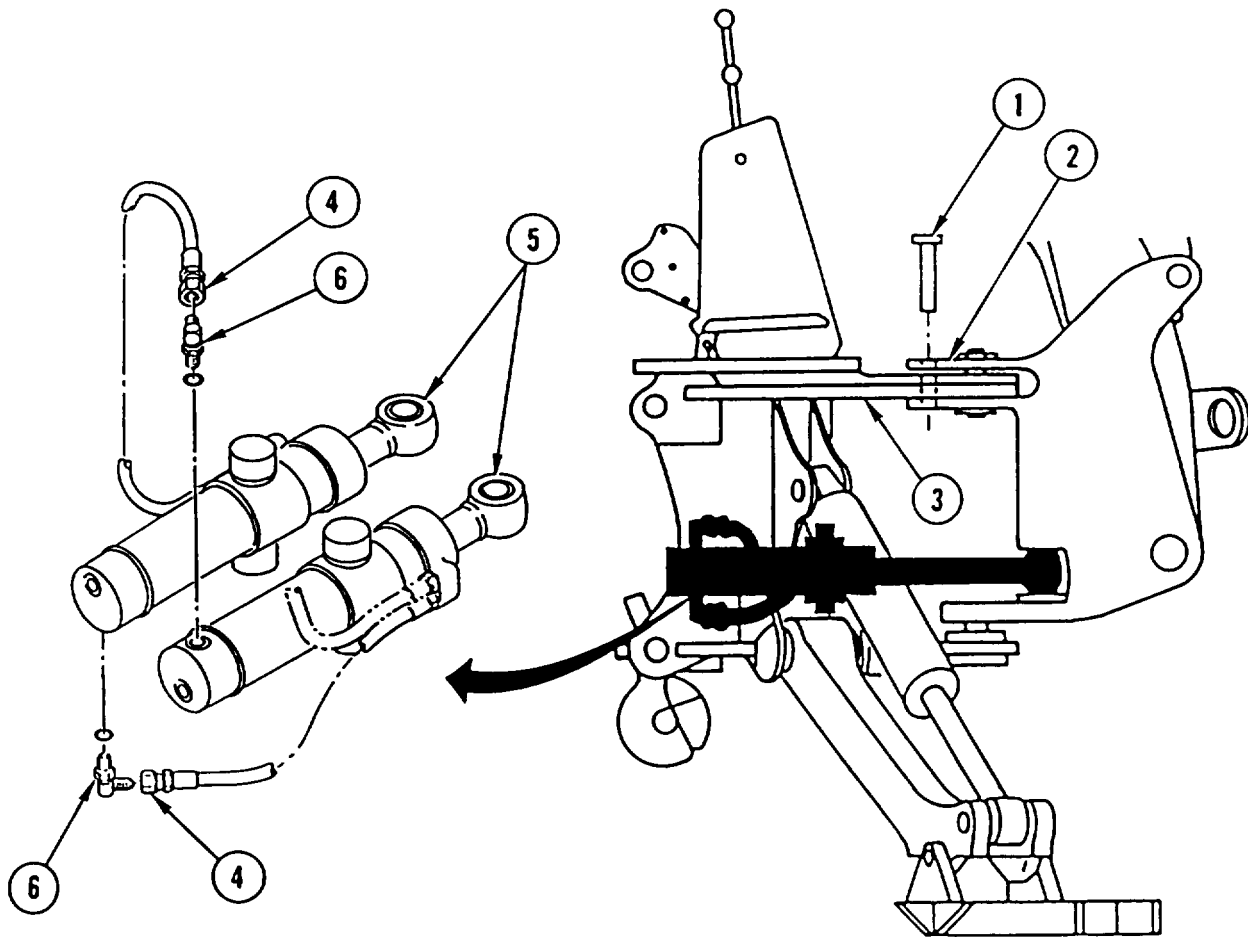

Step 2. Check for damaged swing cylinder packing as follows:

NOTE

The pin, 8-10 in. (200-250 mm) in length, 1-1/2 in. (37.5 mm) in diameter, must be made from rolled stock.

- a. Start engine. Place swing tower in center position and install pin (1) through swing tower (2) and backhoe mounting frame (3) to hold swing tower (2) in center position.

Table 3-5. Troubleshooting (Cont)

Malfunction	Test or Inspection	Corrective Action
-------------	--------------------	-------------------

BACKHOE (SEE) (CONT)**NOTE**

Use threaded plug in hose. Failure to do so will result in spilled hydraulic oil.

- b. Stop engine. Disconnect hose (4) from closed end of swing cylinder (5) and install threaded plug.
- c. Start and run engine at 2000 rpm.

NOTE

During step d, there may be a small amount of hydraulic oil leaking, either drops or a small stream the diameter of a pencil lead. This is normal. Use drip pan to catch oil.

- d. Move swing control lever to move backhoe (to left for left swing cylinder or to right for right swing cylinder). Hold lever in position and check for leaks from fitting (6) at closed end of swing cylinder.
 - If there is excessive leakage from fitting, replace swing cylinder (page 4-660).
 - If there is not excessive leakage from fitting, notify direct support maintenance.

128. STABILIZER CYLINDER DRIFTS.**NOTE**

Steps 1 and 2 are the same for both stabilizer cylinders.

Step 1. Check for loose and damaged hydraulic lines.

- If hydraulic lines are loose or damaged, tighten loose connections or replace hydraulic lines (pages 4-600, 4-602, 4-604).
- If hydraulic lines are not loose or damaged, go to step 2.

Table 3-5. Troubleshooting (Cont)

Malfunction	Test or Inspection	Corrective Action
-------------	--------------------	-------------------

BACKHOE (SEE) (CONT)

Step 2. Check for damaged stabilizer cylinder packing as follows:

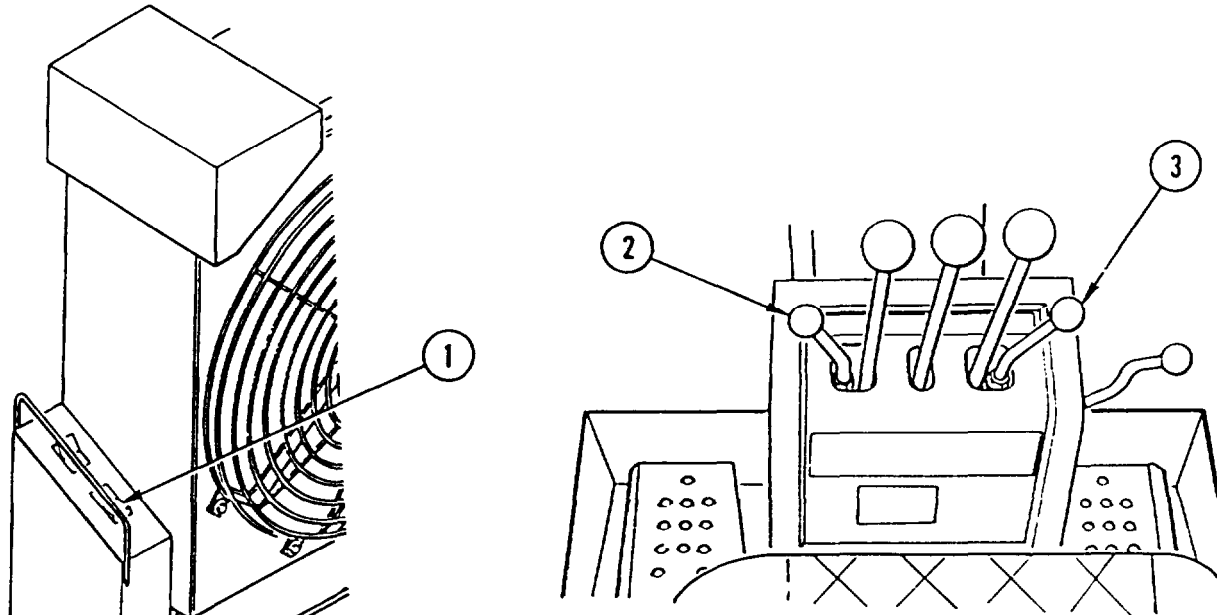

- a. Start engine. Set engine RPM switch (1) to HI.
- b. Lift backhoe from three-point stance, roll bucket up, and fold dipper in toward boom.
- c. Push both stabilizer control levers (2 and 3) outward to lower stabilizers until stabilizer cylinder rods are fully extended. Allow control levers (2 and 3) to return to neutral.
- d. Stop engine.
- e. Push left (2) or right (3) stabilizer control lever outward. If backhoe moves, immediately release either left or right stabilizer control lever.
 - if backhoe moves, replace defective stabilizer cylinder (page 4-673).
 - If backhoe does not move, notify direct support maintenance.

129. BACKHOE SHOWS ERRATIC MOVEMENTS WHILE SWINGING.

Check for incorrectly installed and missing restrictors in closed ends of swing cylinders as follows:

Table 3-5. Troubleshooting (Cont)

Malfunction	Test or Inspection	Corrective Action
-------------	--------------------	-------------------

BACKHOE (SEE) (CONT)

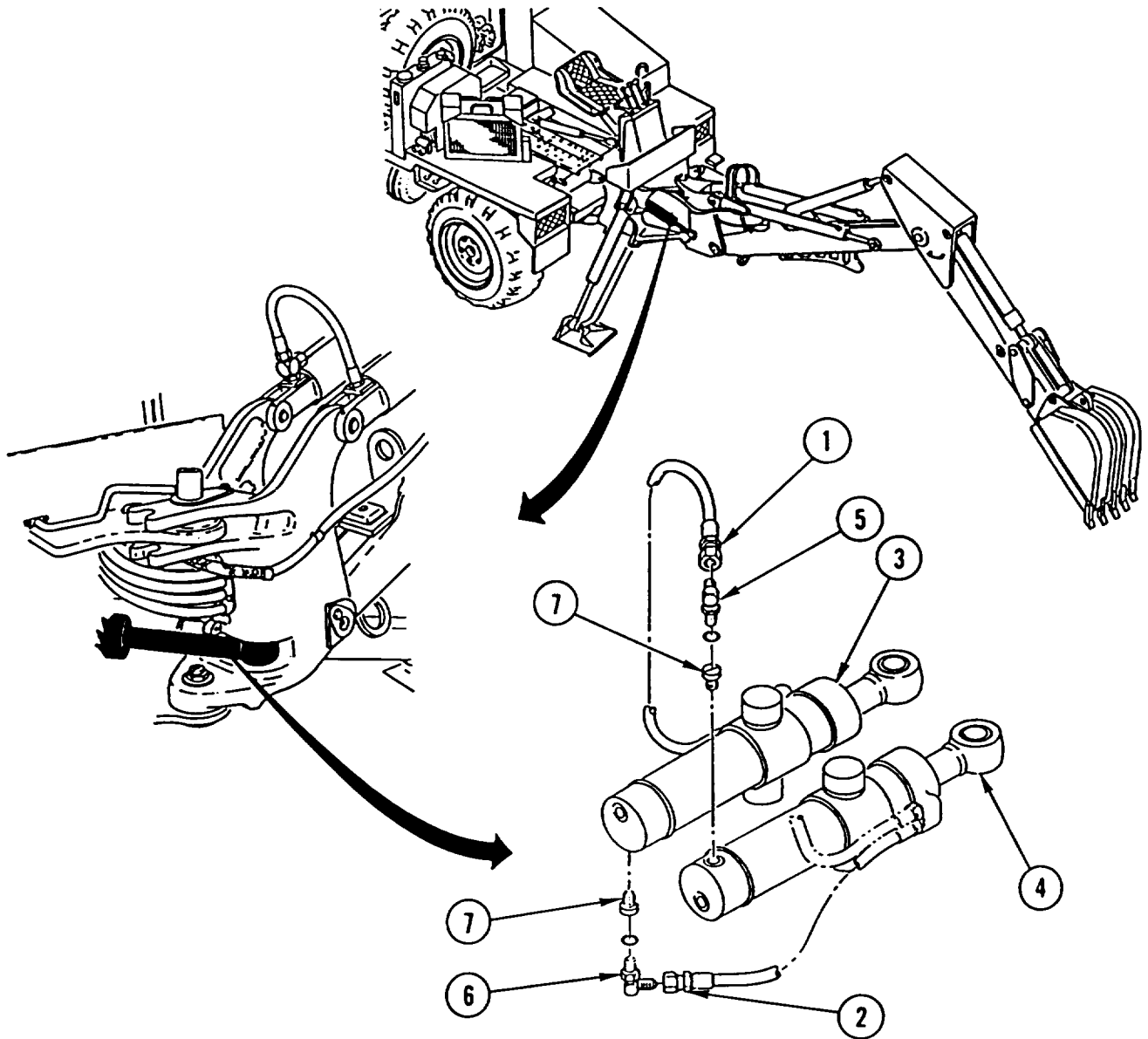

- a. Disconnect two hoses (1 and 2) at closed ends of swing cylinders (3 and 4).
- b. Remove two fittings (5 and 6) and remove restrictors (7).
 - If restrictor was incorrectly installed or is missing, install restrictor with small end toward swing cylinder.
 - If restrictor is not missing, notify direct support maintenance.

Table 3-5. Troubleshooting (Cont)

Malfunction	Test or Inspection	Corrective Action
-------------	--------------------	-------------------

BACKHOE (SEE) (CONT)

130. BOOM LOWERS TOO FAST.

Check for incorrectly installed and missing restrictor in B port of boom section, backhoe control valve, as follows:

- a. Lower bucket to floor.

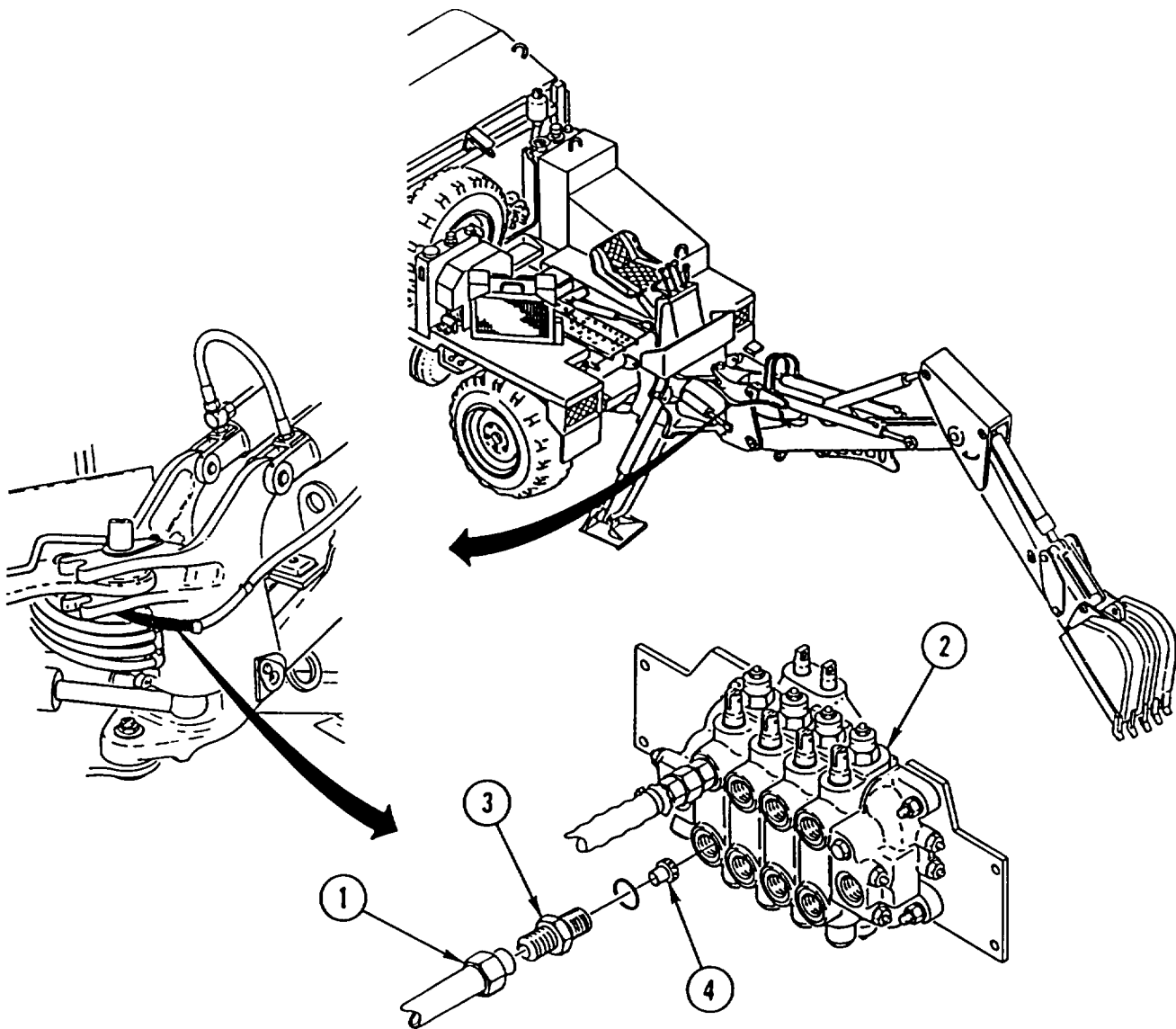

Table 3-5. Troubleshooting (Cont)

Malfunction	Test or Inspection	Corrective Action
-------------	--------------------	-------------------

BACKHOE (SEE) (CONT)

- b. Disconnect tube (1) at B port of boom section (2) and remove fitting (3) and restrictor (4) from B port.
- If restrictor was incorrectly installed or is missing, install restrictor with large end toward boom section.
 - If restrictor is not missing, notify direct support maintenance.

CRANE (HMMH)**131. CRANE CONTROLS WILL NOT RESPOND.**

Step 1. Check for low oil level in rear hydraulic tank.

- If oil level is low, add oil (LO 5-2420-224-12).
- If oil level is not low, go to step 2.

Step 2. Check for loose and damaged hydraulic lines.

- If hydraulic lines are loose or damaged, tighten loose connections or replace hydraulic lines (pages 4-632, 4-634, 4-636, 4-638, 4-640, 4-642, 4-644, 4-646, 4-648).
- If hydraulic lines are not loose or damaged, notify direct support maintenance.

132. CRANE OPERATION SLOWS DOWN.

Step 1. Check for low oil level in rear hydraulic tank.

- If oil level is low, add oil (LO 5-2420-224-12).
- If oil level is not low, go to step 2.

Step 2. Check engine rpm on tachometer. Engine speed should be 1100 rpm.

- If engine speed is not 1100 rpm, adjust air cylinder (page 4-77).
- If engine speed is 1100 rpm, go to step 3.

Step 3. Check condition of rear hydraulic tank filters.

- If rear hydraulic tank filters are unserviceable, change rear hydraulic tank filters (page 4-720).
- If rear hydraulic tank filters are serviceable, notify direct support maintenance.

Table 3-5. Troubleshooting (Cont)

Malfunction	Test or Inspection	Corrective Action
-------------	--------------------	-------------------

CRANE (HMMH) (CONT)

133. CRANE OPERATION UNUSUALLY NOISY.

- Step 1. Check for low oil level in rear hydraulic tank.
 - If oil level is low, add oil (LO 5-2420-224-12).
 - if oil level is not low, go to step 2.
- Step 2. Check for improperly lubricated cylinder pivot pins.
 - If pivot pins are not properly lubricated, lubricate pivot pins (LO 5-2420-224-12).
 - If pivot pins are properly lubricated, go to step 3.
- Step 3. Check condition of rear hydraulic tank filters.
 - If rear hydraulic tank filters are unserviceable, change rear hydraulic tank filters (page 4-720).
 - If rear hydraulic tank filters are serviceable, go to step 4.
- Step 4. Check for loose and damaged hydraulic lines.
 - If hydraulic lines are loose or damaged, tighten loose connections or replace hydraulic lines (pages 4-632, 4-634, 4-636, 4-638, 4-640, 4-642, 4-644, 4-646, 4-648).
 - If hydraulic lines are not loose or damaged, notify direct support maintenance.

134. VERTICAL OUTRIGGER CYLINDER YIELDS OR DRIFTS.

NOTE

Step is the same for both vertical outrigger cylinders.

- Check for leaking and damaged hydraulic lines.
- If hydraulic lines are leaking or damaged, tighten loose connections or replace hydraulic lines (page 4-648).
 - If hydraulic lines are not leaking or damaged, replace vertical outrigger cylinder (page 4-700).

135. HORIZONTAL OUTRIGGER CYLINDER WILL NOT RETRACT.

NOTE

Step is the same for both horizontal outrigger cylinders.

- Check for leaking and damaged hydraulic lines.
- If hydraulic lines are leaking or damaged, tighten loose connections or replace hydraulic lines (page 4-646).
 - If hydraulic lines are not leaking or damaged, replace horizontal outrigger cylinder (page 4-698).

Table 3-5. Troubleshooting (Cont)

Malfunction	Test or Inspection	Corrective Action
-------------	--------------------	-------------------

CRANE (HMMH) (CONT)

136. INNER BOOM LIFT CYLINDER DRIFTS.

NOTE

Steps 1 and 2 are the same for both inner boom lift cylinders except as noted.

Step 1. Check for damaged packings and seals in inner boom lift cylinder as follows:

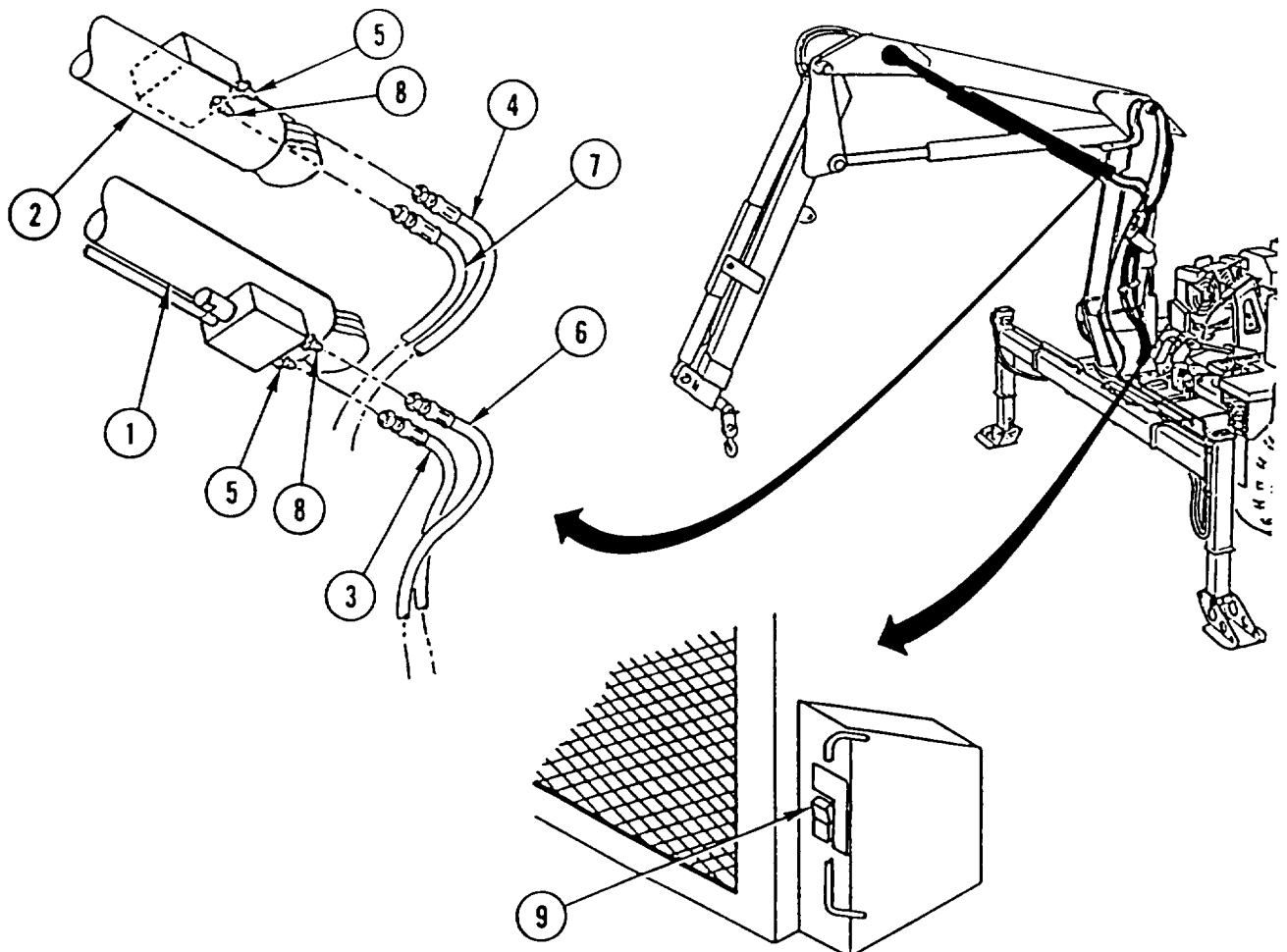

- a. Start engine. Extend inner boom lift cylinders (1 and 2) to end of stroke.
- b. Stop engine.

Table 3-5. Troubleshooting (Cont)

Malfunction	Test or Inspection	Corrective Action
-------------	--------------------	-------------------

CRANE (HMMH) (CONT)

NOTE

- Step c is for passenger side inner boom lift cylinder.
- Step d is for driver side inner boom lift cylinder.
- Use threaded plugs in hoses in steps c, d, h, and i. Failure to do so will result in spilled hydraulic oil.
 - c. Remove lower hose (3) from passenger side inner boom lift cylinder (1) and install threaded plug in hose.
 - d. Remove upper hose (4) from driver side inner boom lift cylinder (2) and install threaded plug in hose.
 - e. Start engine. Move control lever to extend inner boom lift cylinders (1 and 2) and check for oil leak from fittings (5).
 - If there is leakage from fittings, replace inner boom lift cylinder (page 4-692).
 - If there is no leakage from fittings, stop engine and go to step f.
 - f. Remove threaded plugs from hoses (3 and 4) and install hose on inner boom lift cylinders (1 and 2).
 - g. Start engine, retract inner boom lift cylinder completely, and stop engine.

NOTE

- Step h is for passenger side inner boom lift cylinder.
- Step i is for driver side inner boom lift cylinder.
 - h. Remove upper hose (6) from passenger side inner boom lift cylinder (1) and install threaded plug.
 - i. Remove lower hose (7) from driver side inner boom lift cylinder (2) and install threaded plug.
 - j. Start engine. Retract inner boom lift cylinders (1 and 2) and check for oil leak from fittings (8).
 - If there is leakage from fittings, replace inner boom lift cylinder (page 4-692).
 - If there is no leakage from fittings, go to step 2.

Table 3-5. Troubleshooting (Cont)

Malfunction	Test or Inspection	Corrective Action
-------------	--------------------	-------------------

CRANE (HMMH) (CONT)

Step 2. Check inner boom lift cylinder holding valves as follows:

- a. Start engine. Set auxiliary throttle switch (9) to CRANE.
- b. Lift load. Allow control lever to go to neutral.
- c. Set auxiliary throttle switch (9) to IDLE. Stop engine.
- d. Move control lever to attempt to lower load to floor.
 - If load lowers any amount, replace inner boom lift cylinder (page 4-692).
 - If load does not lower, notify direct support maintenance.

Table 3-5. Troubleshooting (Cont)

Malfunction	Test or Inspection	Corrective Action
-------------	--------------------	-------------------

CRANE (HMMH) (CONT)

137. OUTER BOOM CYLINDER DRIFTS WHEN LOADED AND CONTROLS IN NEUTRAL.

Step 1. Check for damaged packings and seals in outer boom cylinder as follows:

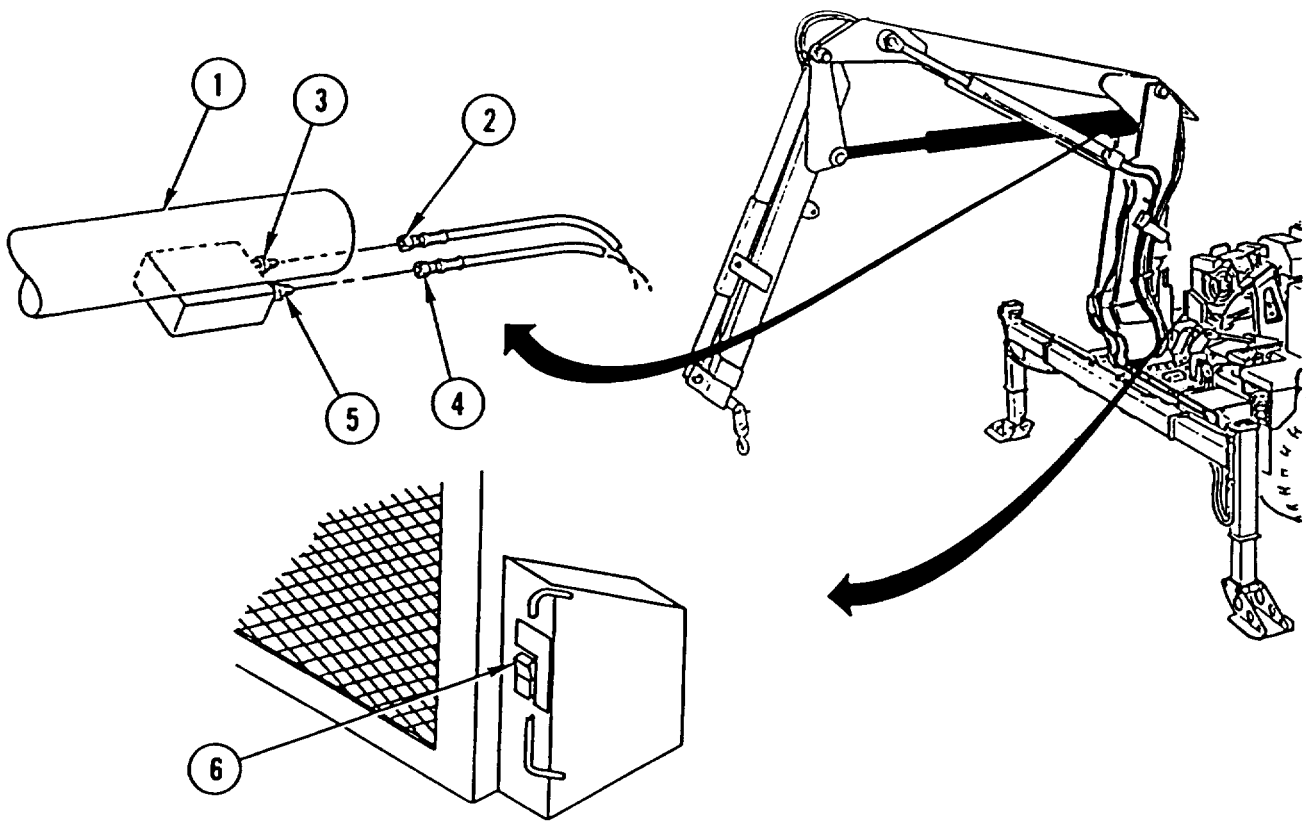

- Start engine. Extend outer boom cylinder (1) to end of stroke.
- Stop engine.

NOTE

Use threaded plugs in hoses in steps c and g. Failure to do so will result in spilled hydraulic oil.

- Remove hose (2) from outer boom cylinder (1) and install threaded plug in hose.

Table 3-5. Troubleshooting (Cont)

Malfunction	Test or Inspection	Corrective Action
CRANE (HMMH) (CONT)		
	d.	<p>Start engine. Move control lever to extend outer boom cylinder (1) and check for oil leak from fitting (3).</p> <ul style="list-style-type: none"> • If there is leakage from fitting, replace outer boom cylinder (page 4-696). • If there is no leakage from fitting, stop engine and go to step e.
	e.	Remove threaded plug from hose (2) and install hose on outer boom cylinder (1).
	f.	Start engine, retract outer boom cylinder completely, and stop engine.
	g.	Disconnect hose (4) from outer boom cylinder (1) and install threaded plug.
	h.	<p>Start engine. Retract outer boom cylinder (1) and check for oil leak from fitting (5j).</p> <ul style="list-style-type: none"> • If there is leakage from fitting, replace outer boom cylinder (page 4-696). • If there is no leakage from fitting, go to step 2.
	Step 2.	Check outer boom cylinder holding valve as follows:
	a.	Start engine. Set auxiliary throttle switch (6) to CRANE.
	b.	Lift load. Allow control lever to go to neutral.
	c.	Set auxiliary throttle switch (6) to IDLE. Stop engine.
	d.	<p>Move control lever to attempt to lower load to floor.</p> <ul style="list-style-type: none"> • If load lowers any amount, replace outer boom cylinder (page 4-696). • If load does not lower, notify direct support maintenance.

FRONT LOADER (SEE)**138. FRONT LOADER OPERATES SLOW.**

Check for loose and damaged hydraulic lines.

- If hydraulic lines are loose or damaged, tighten loose connections or replace hydraulic lines (pages 4-569, 4-572, 4-574, 4-576, 4-578, 4-580, 4-582, 4-584, 4-586, 4-588).
- If hydraulic lines are not loose or damaged, notify direct support maintenance.

Table 3-5. Troubleshooting (Cont)

Malfunction	Test or Inspection	Corrective Action
-------------	--------------------	-------------------

FRONT LOADER (SEE) (CONT)

139. FRONT LOADER WILL NOT RAISE OR LOWER.

Step 1. Check quick-disconnect connectors for correct installation.

- If quick-disconnect connectors are not correctly installed, install connectors correctly.
- If quick-disconnect connectors are correctly installed, go to step 2.

Step 2. Check for loose and damaged hydraulic lines.

- If hydraulic lines are loose or damaged, tighten loose connections or replace hydraulic lines (pages 4-569, 4-572, 4-578, 4-580, 4-582, 4-584, 4-586, 4-588).
- If hydraulic lines are not loose or damaged, notify direct support maintenance.

140. FRONT LOADER WILL NOT LOWER USING BUCKET SWITCH.

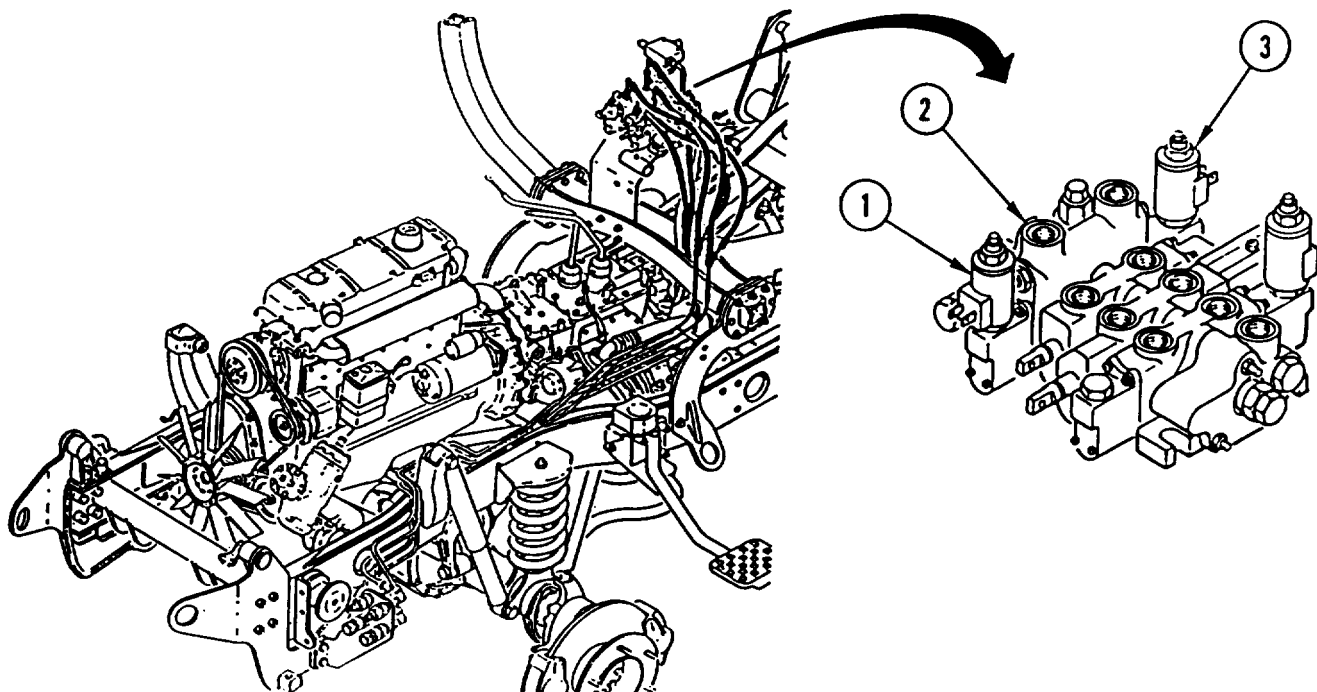

Table 3-5. Troubleshooting (Cont)

Malfunction	Test or Inspection	Corrective Action
-------------	--------------------	-------------------

FRONT LOADER (SEE) (CONT)

Set hand throttle to 1200 rpm and depress button on solenoid (1) of control valve (2).

- If front loader lowers, perform Malfunction 77.
- If front loader does not lower, notify direct support maintenance.

141. FRONT LOADER WILL NOT RAISE USING BUCKET SWITCH.

Set hand throttle to 1200 rpm and depress button on solenoid (3) of control valve (2).

- If front loader raises, perform Malfunction 77.
- If front loader does not raise, notify direct support maintenance.

142. LOADER BOOM CYLINDER DRIFTS.

NOTE

Steps 1 and 2 are the same for both loader boom cylinders.

Step 1. Check for loose and damaged hydraulic lines.

- If hydraulic lines are loose or damaged, tighten loose connections or replace hydraulic lines (pages 4-569, 4-572).
- If hydraulic lines are not loose or damaged, go to step 2.

Step 2. Check for damaged loader boom cylinder packing as follows:

- a. Start engine. Place front loader in fully raised position.
- b. Stop engine.

Table 3-5. Troubleshooting (Cont)

Malfunction	Test or Inspection	Corrective Action
-------------	--------------------	-------------------

FRONT LOADER (SEE) (CONT)

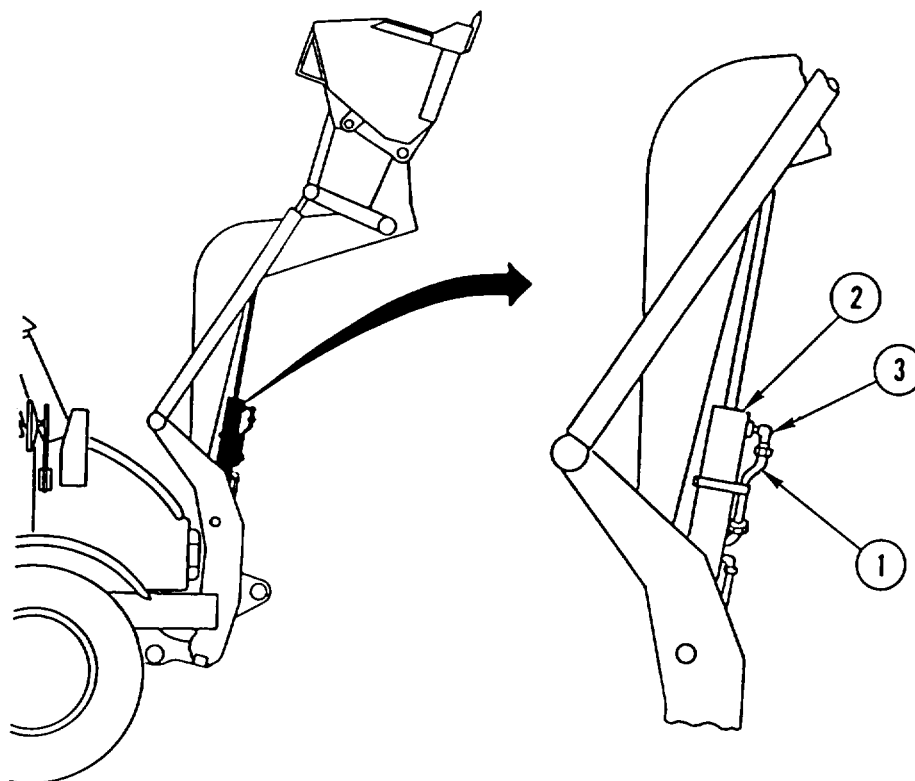

NOTE

Use threaded plugs in hoses in steps c and i. Failure to do so will result in spilled hydraulic oil.

- c. Support loader bucket to keep loader lift arm in position. Disconnect hose (1) at rod end of each loader boom cylinder (2) and install threaded plug.
- d. Start and run engine at idle.

Table 3-5. Troubleshooting (Cont)

Malfunction	Test or Inspection	Corrective Action
-------------	--------------------	-------------------

FRONT LOADER (SEE) (CONT)

NOTE

During steps e and j, there may be a small amount of hydraulic oil leaking, either drops or a small stream the diameter of a pencil lead. This is normal. Use drip pan to catch oil.

- e. Move loader control lever to raise position. Hold lever in raise position and have assistant check for leaks from fitting (3) at rod end of loader boom cylinder (2).
 - If there is excessive leakage from fitting, replace loader boom cylinder (page 4-654).
 - If there is not excessive leakage from fitting, go to step f.
- f. Stop engine. Remove threaded plug and connect hose (1).

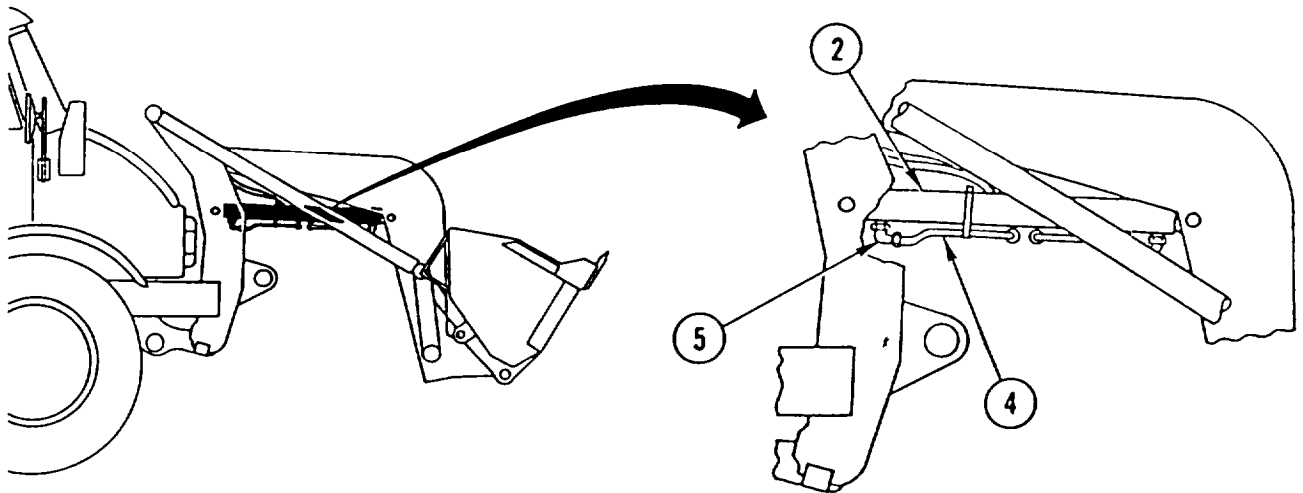

- g. Start engine. Place front loader in transport position.
- h. Stop engine.
- i. Disconnect hose (4) at cylinder end of loader boom cylinder (2) and install threaded plug.
- j. Start and run engine at idle. Move loader control lever to lower position. Hold lever in lower position and have assistant check for leaks from fitting (5) at cylinder' end of loader boom cylinder (2).
 - If there is excessive leakage from fitting, replace loader boom cylinder (page 4-654).
 - If there is not excessive leakage from fitting, notify direct support maintenance.

Table 3-5. Troubleshooting (Cont)

Malfunction	Test or Inspection	Corrective Action
-------------	--------------------	-------------------

FRONT LOADER (SEE) (CONT)

143. BUCKET ROLLBACK CYLINDER DRIFTS.

NOTE

Steps 1 and 2 are the same for both bucket rollback cylinders.

Step 1. Check for loose and damaged hydraulic lines.

- If hydraulic lines are loose or damaged, tighten loose connections or replace hydraulic lines (pages 4-574, 4-576).
- If hydraulic lines are not loose or damaged, go to step 2.

Step 2. Check for damaged bucket rollback cylinder packing as follows:

- a. Start engine. Place bucket in full rollback position.
- b. Stop engine.

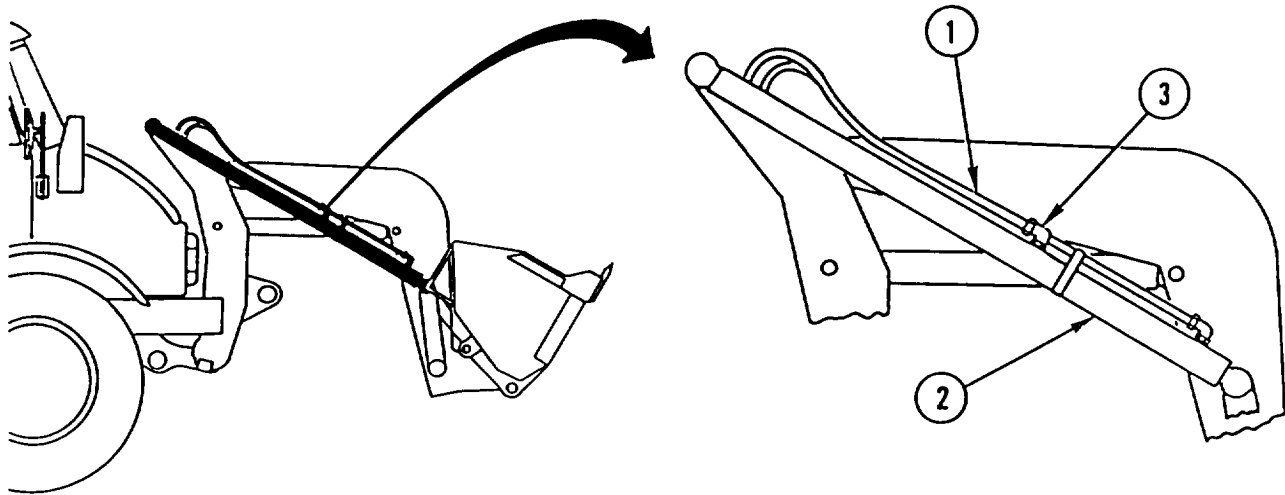

NOTE

Use threaded plugs in hoses in steps c and i. Failure to do so will result in spilled hydraulic oil.

- c. Support bucket in full rollback position. Disconnect hose (1) from rod end of each bucket rollback cylinder (2) and install threaded plugs.
- d. Start and run engine at idle.

Table 3-5. Troubleshooting (Cont)

Malfunction	Test or Inspection	Corrective Action
-------------	--------------------	-------------------

FRONT LOADER (SEE) (CONT)

NOTE

During steps e and j, there may be a small amount of hydraulic oil leaking, either drops or a small stream the diameter of a pencil lead. This is normal. Use drip pan to catch oil.

- e. Move bucket control lever to rollback position. Hold lever in rollback position and have assistant check for leaks from fitting (3) at rod end of each bucket rollback cylinder (2).
 - If there is excessive leakage from fitting, replace bucket rollback cylinder (page 4-656).
 - If there is not excessive leakage from fitting, go to step f.
- f. Stop engine. Remove threaded plugs and connect hose (1).

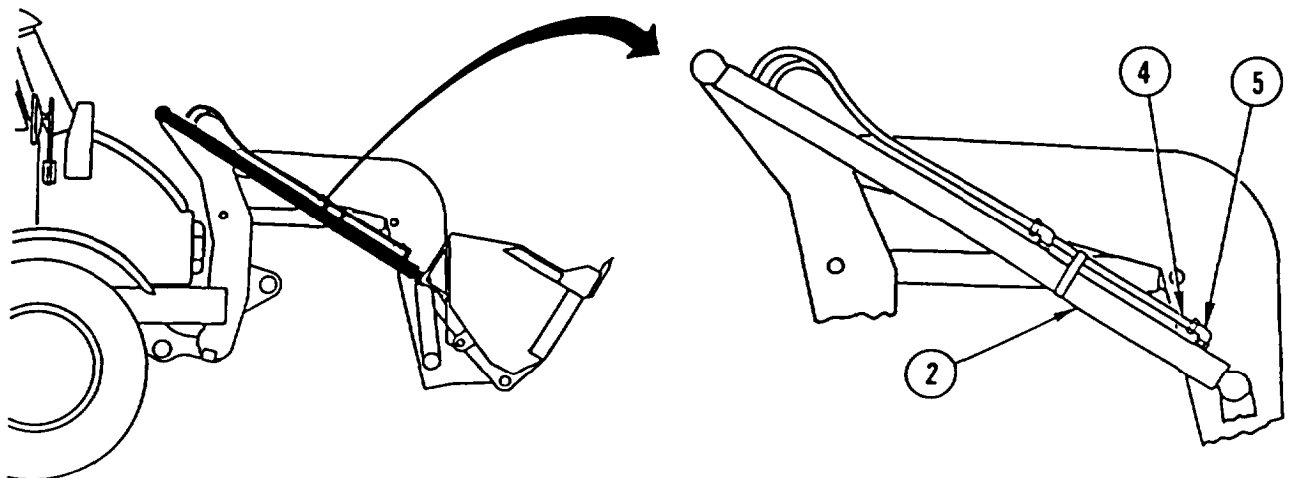

- g. Start engine. Place front loader in transport position.
- h. Place bucket in dump position. Stop engine.
- i. Disconnect hose (4) from cylinder end of each bucket rollback cylinder (2) and install threaded plugs.
- j. Start and run engine at idle. Move bucket control lever to dump position. Hold lever in dump position and have assistant check for leaks from fitting (5) at cylinder end of each bucket rollback cylinder (2).
 - If there is excessive leakage from fitting, replace bucket rollback cylinder (page 4-656).
 - If there is not excessive leakage from fitting, notify direct support maintenance.

Table 3-5. Troubleshooting (Cont)

Malfunction	Test or Inspection	Corrective Action
-------------	--------------------	-------------------

FRONT LOADER (SEE) (CONT)

144. LOAD DROPS WITH CONTROL VALVE IN NEUTRAL.

Step 1. Check for loose and damaged hydraulic lines.

- If hydraulic lines are loose or damaged, tighten loose connections or replace hydraulic lines (page 4-582).
- If hydraulic lines are not loose or damaged, go to step 2.

Step 2. Check control linkages for proper adjustment.

- If control linkages are not properly adjusted, adjust control linkages (page 4-532).
- If control linkages are properly adjusted, go to step 3.

Step 3. Check load drop rate as follows:

- a. Load bucket with 1,000 lb.
- b. Start engine and cycle oil until oil is at operating temperature of 120° F (49° C).
- c. Lift load 3-4 ft (0.9-1.2 m) off ground. Stop engine.

NOTE

Maximum allowable drop is 1 ft.

- d. Allow load to stay suspended for 10 minutes.
 - If load drops more than 1 ft, replace relief valve (page 4-568).
 - If problem continues, notify direct support maintenance.

145. CONTROL VALVE STICKS OR WORKS HARD.

Check control linkages for proper adjustment.

- If control linkages are not properly adjusted, adjust control linkages (page 4-532).
- If control linkages are properly adjusted, notify direct support maintenance.

Index

Subject	Page
A	
Accelerator Linkage Adjustment	4-68
Accelerator Linkage Replacement	4-64
Accelerator Pedal and Linkage Replacement	4-58
Accessory Air Supply Overflow Valve and Fittings Replacement	4-304
Accumulator, Hydraulic Suspension Lockout, Replacement	4-516
Air Brake Booster Replacement.	4-295
Air Cleaner Ducts Replacement	4-38
Air Cleaner Filter Elements Replacement	4-35
Air Cleaner Replacement.	4-32
Air Cleaner Restrictor Indicator Switch Replacement	4-205
Air Cylinder Adjustment (HMMH)	4-77
Air Cylinder Adjustment (SEE)..	4-76
Air Cylinder Replacement (HMMH).	4-74
Air Cylinder Replacement (SEE).	4-72
Air Lines, Engine Inlet and Outlet, Replacement	4-10
Air Pressure and Accessory Air Supply Lines and Fittings Replacement	4-315
Air Pressure Tanks Replacement	4-288
Air Pressure, Relieving	2-23
Air System Supply Lines and Fittings Replacement	4-324
Alarm, Backup, Replacement.	4-214
Alarm, Low Oil Pressure and High Water Temperature, Replacement	4-170
All Wheel Drive Control Cylinder Replacement and Adjustment	4-243
All Wheel Drive Pressure Regulator Replacement.	4-242
All Wheel Drive Selector Valve Replacement	4-240
Alternator and Alternator Bracket Replacement.	4-112
Alternator Bracket, Alternator and, Replacement.	4-112
Ammeter Replacement	4-135
Antifreeze Device Replacement	4-300
Antifreeze Reservoir Replacement	4-298
Arm, Steering, Replacement..	4-349
Auxiliary Headlight Adjustment.	4-179
Auxiliary Headlight Replacement	4-175
Auxiliary Light Control Switch Replacement	4-146
Auxiliary Throttle Switch Replacement	4-156
Axle Vent Hoses Replacement	4-245
B	
Backhoe Assembly Replacement.	4-754
Backhoe Boom Cylinder Hydraulic Lines and Fittings Replacement	4-610
Backhoe Boom Cylinder Replacement	4-658
Backhoe Boom Latch Release Lever Replacement	4-768
Backhoe Boom Latch Replacement	4-770
Backhoe Boom Replacement.	4-752
Backhoe Bucket (Ripper) Bearings Replacement.	4-763
Backhoe Bucket Cylinder Hydraulic Lines and Fittings Replacement	4-616
Backhoe Bucket Cylinder Replacement	4-668
Backhoe Bucket Links Replacement	4-764

Subject

Page

B (CONT)

Backhoe Bucket Replacement	4-762
Backhoe Bucket/Ripper Tooth Replacement.	4-766
Backhoe Control Lever Replacement	4-523
Backhoe Control Rod Adjustment	4-531
Backhoe Control Tower Replacement	4-404
Backhoe Control Valve, Boom Section Hydraulic Lines and Fittings Replacement	4-612
Backhoe Control Valve, Bucket Section Hydraulic Lines and Fittings Replacement	4-618
Backhoe Control Valve, Swing Section Hydraulic Lines and Fittings Replacement	4-608
Backhoe Dipper Cylinder Hydraulic Lines and Fittings Replacement	4-614
Backhoe Dipper Cylinder Replacement	4-670
Backhoe Dipper Replacement and Repair	4-760
Backhoe Seat Repair	4-445
Backhoe Seat Replacement	4-444
Backhoe Stabilizer Control Valve Hydraulic Lines and Fittings Replacement	4-604
Backhoe Stabilizer Cylinder Replacement	4-673
Backhoe Stabilizer Replacement.	4-774
Backhoe Subframe Deck Replacement	4-362
Backhoe Swing Control Pedal Adjustment	4-522
Backhoe Swing Control Pedal Replacement	4-518
Backhoe Swing Cylinder Hydraulic Lines and Fittings Replacement	4-606
Backhoe Swing Cylinder Replacement	4-660
Backhoe Swing Tower Replacement	4-772
Backhoe Travel Lock Replacement and Repair	4-678
Backhoe Travel Lock Replacement and Repair	4-681
Backhoe/Crane Hydraulic Lines and Fittings Replacement	4-598
Backhoe/Crane Latch Cylinder Hydraulic Lines and Fittings Replacement	4-596
Backhoe/Crane Latch Cylinder Mounting Replacement	4-677
Backhoe/Crane Latch Cylinder Replacement	4-684
Backhoe/Crane Tilt Cylinder Hydraulic Lines and Fittings Replacement	4-594
Backhoe/Crane Tilt Cylinder Replacement	4-675
Backup Alarm Replacement	4-214
Backup Alarm Switch Replacement	4-208
Batteries, Disconnecting/Connecting	2-24
Battery Box Repair	4-228
Battery Box Replacement	4-226
Battery Cables Replacement	4-221
Battery Replacement	4-219
Bearing, Steering Upper Shaft, Replacement	4-351
Bearings, Backhoe Bucket (Ripper), Replacement	4-763
Belt, Fan, Adjustment	4-108
Belt, Fan, Replacement	4-106
Belt, Front Hydraulic Pump, Replacement and Adjustment	4-506
Belt, Power Steering Pump, Replacement and Adjustment	4-356
Belt, Seat, Replacement	4-451
Bleeding, Brake System	4-262
Blocking the Vehicle.	2-22
Boom, Backhoe, Replacement.	4-752
Box, Hydraulic Accessory, Replacement and Repair (HMMH)	4-468
Box, Hydraulic Accessory, Replacement and Repair (SEE)	4-466
Bracket and Seal, Steering Wheel, Replacement	4-344

Subject	Page
B (CONT)	
Bracket, Decontamination Mounting, Replacement	4-363
Brake Booster and Air Pressure Lines and Fittings Replacement	4-318
Brake Caliper Replacement	4-274
Brake Disc and Hub Replacement	4-265
Brake Fluid Reservoir Replacement	4-257
Brake Light Diode Replacement	4-168
Brake Light Switch Replacement	4-200
Brake Master Cylinder Replacement..	4-276
Brake Pedal Adjustment	4-287
Brake Pedal Replacement	4-286
Brake Pressure Regulator (ALB Valve) Line and Fittings Replacement	4-282
Brake System Bleeding	4-262
Brake, Parkina, Adjustment	4-254
Bucket and Auxiliary Throttle Switches Replacement	4-151
Bucket, Backhoe, Replacement	4-762
Bucket, Front Loader, Replacement	4-802
Bumpers, Front Rubber, Replacement	4-367
C	
Cab Door and Window Replacement and Repair.	4-393
Cab Door Replacement	4-392
Cab Door Seal Replacement	4-413
Cab Drain Plug Replacement	4-414
Cab Floor Linings Replacement	4-454
Cab Heater Replacement	4-490
Cab Shock Absorbers and Mountings Replacement.	4-415
Cab Tilt and Lower	4-418
Cables, Battery, Replacement	4-221
Caliper, Brake, Replacement	4-274
Canopy (FOPS) Replacement	4-387
Chain and Bar, Chain Saw, Replacement	4-744
Chain Saw Chain and Bar Replacement	4-744
Chain Saw Hoses Replacement	4-742
Chain Saw Trigger, Guard, and Handle Bar Replacement	4-746
Chain, Forklift Carriage, Adjustment	4-559
Chain, Forklift Mast, Adjustment..	4-562
Chassis Tool Box/Deck Plate Replacement	4-364
Cleaning Instructions, General..	2-16
Clothes Hook, Sun Visor, and Grip Handles Replacement	4-455
Clutch Hydraulic Reservoir Lines and Fittings Replacement	4-17
Clutch Hydraulic Reservoir Replacement	4-15
Clutch Master Cylinder Replacement	4-22
Clutch Pedal Replacement and Adjustment	4-13
Clutch Slave Cylinder Adjustment	4-21
Clutch Slave Cylinder Replacement	4-19
Cold Start Aid Replacement	4-55
Cold Start Switch Replacement..	4-136
Common Tools and Equipment.	2-1
Connection, Trailer, Replacement	4-230

Subject	Page
C (CONT)	
Control Arm, Front, Replacement.	4-374
Control Arm, Rear, Replacement.	4-375
Control Rod, Backhoe, Adjustment	4-531
Controls and Linkages, Crane, Replacement and Adjustment	4-538
Controls, Front Loader/Forklift Control Valve, Replacement	4-532
Controls, Hydraulic Suspension Lockout, Replacement	4-142
Controls, Parking Brake, Replacement	4-251
Coolant Expansion Tank Filler Cap Pressure Test.	4-90
Coolant Expansion Tank Replacement	4-96
Coolant Expansion Tank Support Replacement	4-97
Coolant Hoses and Clamps Replacement	4-98
Coolant Thermostat Replacement.	4-100
Coolant Water Outlet Replacement	4-101
Cooler, Hydraulic Oil, Replacement	4-722
Cooling System Service	4-87
Cooling System Test	4-89
Counter Engine Revolution (Hourmeter) Replacement.	4-733
Coupling, Front Trailer, Replacement	4-259
Cover and Gasket, Valve, Replacement	4-3
Crane Controls and Linkages Replacement and Adjustment.	4-538
Crane External End Extension Cylinder Hydraulic Lines and Fittings Replacement	4-632
Crane External End Extension Cylinder Replacement.	4-690
Crane Hook Assembly Replacement	4-783
Crane Horizontal Outrigger Cylinder Hydraulic Lines and Fittings Replacement.	4-646
Crane Horizontal Outrigger Cylinder Replacement.	4-698
Crane Hydraulic Motor Replacement	4-509
Crane Inner Boom Lift Cylinder Hydraulic Lines and Fittings Replacement.	4-636
Crane Inner Boom Lift Cylinder Replacement	4-692
Crane Mast Floodlight Replacement and Repair.	4-188
Crane Mast Locking Cylinder Hydraulic Lines and Fittings Replacement.	4-638
Crane Mast Locking Cylinder Replacement	4-694
Crane Outer Boom Cylinder Hydraulic Lines and Fittings Replacement.	4-644
Crane Outer Boom Cylinder Replacement	4-696
Crane Rear Outrigger Replacement	4-784
Crane Replacement	4-776
Crane Return Lines and Fittings Replacement.	4-642
Crane Rotation Lock Replacement and Adjustment.	4-790
Crane Supply Lines and Fittings Replacement.	4-640
Crane Travel Lock Replacement and Adjustment	4-786
Crane Turntable Motor Hydraulic Lines and Fittings Replacement.	4-634
Crane Vertical Outrigger Cylinder Hydraulic Lines and Fittings Replacement.	4-648
Crane Vertical Outrigger Cylinder Replacement	4-700
Crosshead, Forklift, Replacement and Adjustment.	4-541
Cylinder	
Air, Adjustment (HMMH).	4-77
Air, Adjustment (SEE)	4-76
Air, Replacement (HMMH)	4-74
Air, Replacement (SEE)	4-72
All Wheel Drive Control, Replacement and Adjustment.	4-243
Backhoe Boom, Replacement.. . . .	4-658

Subject	Page
C (CONT)	
Backhoe Bucket, Replacement	4-668
Backhoe Dipper, Replacement	4-670
Backhoe Stabilizer, Replacement	4-673
Backhoe Swing, Replacement	4-660
Backhoe/Crane Latch, Replacement	4-684
Backhoe/Crane Tilt, Replacement	4-675
Brake Master, Replacement	4-276
Clutch Master, Replacement	4-22
Clutch Slave, Adjustment	4-21
Clutch Slave, Replacement	4-19
Crane External End Extension, Replacement	4-690
Crane Horizontal Outrigger, Replacement	4-698
Crane Inner Boom Lift, Replacement.. . . .	4-692
Crane Mast Locking, Replacement	4-694
Crane Outer Boom, Replacement	4-696
Crane Vertical Outrigger, Replacement.. . . .	4-700
Forklift Lift, Bleeding	4-630
Forklift Rotator, Replacement.	4-688
Forklift Tilt, Replacement	4-686
Loader Boom, Replacement	4-654
Loader Bucket Rollback, Replacement	4-656
D	
Data Plates Replacement.	4-492
Deck, Backhoe Subframe, Replacement	4-362
Decontamination Mounting Bracket Replacement	4-363
Defroster and Air Tubes Replacement	4-486
Destruction of Army Materiel to Prevent Enemy Use.	1-1
Differential Lock Indicator Switch Replacement	4-207
Diode, Brake Light, Replacement.	4-168
Dipper, Backhoe, Replacement and Repair	4-760
Disc and Hub, Brake, Replacement	4-265
Disconnecting/Connecting Batteries	2-24
Dome Light Replacement	4-195
Door and Window, Cab, Replacement and Repair	4-393
Door, Cab, Replacement	4-392
Drag Link Replacement and Adjustment	4-346
Drive Shaft, Speedometer, Replacement	4-730
Ducts, Air Cleaner, Replacement.	4-38
E	
Electrical Test Equipment	3 - 1
Electrical Troubleshooting	3-64
Element and Bowl, Engine Oil Filter, Replacement	4-7
Element, Fuel Filter, Replacement	4-48
Element, Power Steering Filter, Replacement	4-359
Engine Inlet and Outlet Air Lines Replacement	4-10
Engine Oil Filter Element and Bowl Replacement	4-7
Engine Oil Hose and Fittings Replacement	4-9

Subject	Page
E (CONT)	
Engine Start Switch Replacement	4-199
Engine Temperature Switch Replacement	4-238
Equipment Description and Data	
Characteristics, Capabilities, and Features	1-3
Equipment Data	1-6
Equipment Differences	1-6
Location and Description of Major Components	1-4
Safety, Care, and Handling	1-8
Exhaust Manifold Screening Plate Replacement	4-85
Exterior Rear View Mirror Replacement	4-476
F	
Fan Belt Adjustment	4-108
Fan Belt Replacement	4-106
Fan Impeller Replacement	4-105
Filler Cap, Coolant Expansion Tank, Pressure Test	4-90
Filter Assembly, Fuel, Replacement and Repair.	4-50
Filter Elements, Air Cleaner, Replacement	4-35
Filter, Front Hydraulic Tank, Replacement	4-709
Filter, Hydraulic Suspension Lockout, Replacement	4-507
Filter, Rear Hydraulic Tank, Replacement	4-720
Filters, Suppressor, Replacement	4-235
Fittings and Controls, Fuel Cap, Replacement	4-47
Floodlight, Crane Mast, Replacement and Repair	4-188
Floor Platform Replacement	4-433
Fluid Regulating Valve Replacement	4-306
Forklift Carriage Chain Adjustment	4-559
Forklift Crosshead Replacement and Adjustment	4-541
Forklift Forks Replacement	4-563
Forklift Front Outrigger Replacement	4-567
Forklift Hydraulic Lines and Fittings Replacement	4-622
Forklift Lift Cylinder Bleeding	4-630
Forklift Lift Cylinder Hydraulic Lines and Fittings Replacement	4-628
Forklift Mast Chain Adjustment	4-562
Forklift Pulley Hydraulic Lines and Fittings Replacement	4-626
Forklift Replacement	4-546
Forklift Rotator Cyliner Hydraulic Lines and Fittings Replacement	4-624
Forklift Rotator Cylinder Replacement..	4-688
Forklift Rotator Replacement	4-555
Forklift Tilt Cylinder Hydraulic Lines and Fittings Replacement	4-620
Forklift Tilt Cylinder Replacement	4-686
Forklift Travel Lock Replacement	4-566
Forks, Forklift, Replacement	4-563
Forms and Reports, Maintenance	1-1
Frame, Front Loader Main, Replacement	4-800
Framework, Operator Seat, Repair	4-442
Front Axle Final Drive Outer Seal Replacement	4-247
Front Axle Torsion Bar Replacement	4-376
Front Blackout Light Replacement and Repair	4-181

Subject

Page

F (CONT)

Front Brake Calipers Hydraulic Lines and Fittings Replacement	4-284
Front Composite Light Replacement and Repair	4-183
Front Control Arm Replacement	4-374
Front Disc Brake Pad Indicator Wiring Harness Replacement	4-231
Front Disc Brake Pad Replacement	4-271
Front Fender and Splash Guard Replacement	4-409
Front Hydraulic Pump Belt Replacement and Adjustment	4-506
Front Hydraulic Pump Lines and Fittings Replacement	4-584
Front Hydraulic Pump Replacement.	4-502
Front Hydraulic System Return Lines and Fittings Replacement	4-588
Front Hydraulic Tank Filter Replacement	4-709
Front Hydraulic Tank Replacement and Repair.	4-702
Front Loader Bucket Replacement	4-802
Front Loader Bucket Tooth Replacement	4-804
Front Loader Hydraulic Lines and Fittings Replacement	4-578
Front Loader Hydraulic Relief Valve Replacement	4-568
Front Loader Lift Arm Replacement.	4-805
Front Loader Main Frame Replacement	4-800
Front Loader Replacement	4-794
Front Loader/Forklift Control Valve Controls Replacement and Adjustment	4-532
Front Loader/Forklift Control Valve Hydraulic Lines and Fittings Replacement	4-582
Front Loader/Forklift Hydraulic Lines and Fittings Replacement	4-580
Front Plate Replacement	4-385
Front Rubber Bumpers Replacement.	4-367
Front Shock Absorbers Replacement (HMMH)	4-369
Front Shock Absorbers Replacement (SEE)	4-368
Front Trailer Coupling Replacement	4-259
Fuel Cap, Fittings, and Controls Replacement	4-47
Fuel Filter Assembly Replacement and Repair	4-50
Fuel Filter Element Replacement.	4-48
Fuel Filter Pre-sediment Bowl and Filter Replacement	4-54
Fuel Injector Lines Replacement.	4-25
Fuel Level Gage Replacement.	4-204
Fuel Primer Pump Replacement	4-29
Fuel System Bleeding	4-41
Fuel Tank Draining	4-40
Fuel Tank Lines and Fittings Replacement	4-44
Fuel Tank Replacement	4-42
Fuse Holder Replacement	4-166
Fuse Replacement.	4-169

G

Gage, Fuel Level, Replacement.	4-204
Gear, Power Steering, Adjustment.	4-354
General Hydraulic System Repair Methods	2-32
General Information	1-1
General Repair and Cleaning Methods	2-15
General Torque Value Instructions	2-22
Grip Handles, Sun Visor, and Clothes Hook Replacement	4-455

Subject	Page
G (CONT)	
Guard, Front Fender and Splash, Replacement	4-409
Guard, Splash, Replacement	4-412
H	
Hammer Drill Hoses Replacement	4-736
Hand Primer Replacement	4-31
Hand Throttle Replacement	4-70
Hand Tool Hydraulic Lines and Fittings Replacement	4-586
Hazard Warning Switch Replacement	4-134
Headlight Replacement	4-173
Headlight, Auxiliary, Adjustment.	4-179
Headlight, Auxiliary, Replacement	4-175
Heater Hoses and Clamps Replacement	4-488
Heater, Cab, Replacement	4-490
Hood, inside Engine, Replacement	4-389
Hood, Outside Engine, Replacement	4-388
Hook Assembly, Crane, Replacement	4-783
Horn Replacement	4-218
Horn, Low Beam/High Beam Switch Replacement	4-215
Hose and Fittings, Engine Oil, Replacement	4-9
Hose Reel Assembly Replacement and Repair	4-459
Hose Reel Motor Spring Replacement	4-464
Hoses and Clamps, Coolant, Replacement	4-98
Hoses and Clamps, Heater, Replacement	4-488
Hoses, Axle Vent, Replacement	4-245
Hoses, Chain Saw, Replacement	4-742
Hoses, Hammer Drill, Replacement	4-736
Hoses, Hydraulic Tool, Replacement	4-471
Hoses, Impact Wrench, Replacement	4-738
Hoses, Pavement Breaker, Replacement	4-740
(Hourmeter), Counter Engine Revolution, Replacement	4-733
Hydraulic Accessory Box Replacement and Repair (HMMH)	4-468
Hydraulic Accessory Box Replacement and Repair (SEE)	4-466
Hydraulic Oil Cooler Replacement	4-722
Hydraulic Oil Cooler Thermal Switch Replacement	4-147
Hydraulic Suspension Lockout Accumulator Replacement	4-516
Hydraulic Suspension Lockout Controls Replacement	4-142
Hydraulic Suspension Lockout Filter Replacement	4-507
Hydraulic Suspension Lockout Lines and Fittings Replacement	4-650
Hydraulic Suspension Lockout Pump and Reservoir Lines and Fittings Replacement	4-652
Hydraulic Suspension Lockout Pump Replacement	4-511
Hydraulic Tank Sight Indicator Replacement	4-719
Hydraulic Tool Hoses Replacement	4-471
I	
Ignition Switch Replacement	4-131
Impact Wrench Hoses Replacement	4-738
Impeller, Fan, Replacement	4-105
Inclinometer Replacement and Adjustment	4-731

Subject	Page
I (CONT)	
Indicator (Gage) Replacement	4-124
Initial Services	2-2
Inside Engine Hood Replacement.	4-389
Inspection Instructions, General.	2-18
Instrument Cluster Panel Light Replacement	4-138
Interior Rear View Mirror Replacement	4-475
Intermediate Speed Shift and Indicator Switch Replacement	4-209
L	
Large Air Pressure Tank Overflow Valve and Fittings Replacement	4-302
Latch Cylinder Mounting, Backhoe/Crane, Replacement	4-677
Latch, Backhoe Boom, Replacement	4-770
Left Backhoe Stabilizer Cylinder Hydraulic Lines and Fittings Replacement	4-602
Left Loader Boom Cylinder Hydraulic Lines and Fittings Replacement	4-569
Left Loader Bucket Rollback Cylinder Hydraulic Lines and Fittings Replacement	4-574
Lever, Backhoe Boom Latch Release, Replacement	4-768
Lever, Backhoe Control, Replacement	4-523
Lever, Turn Signal, Replacement.	4-122
Lift Arm, Front Loader, Replacement	4-805
Light, Dome, Replacement	4-195
Light, Front Blackout, Replacement and Repair	4-181
Light, Front Composite, Replacement and Repair	4-183
Light, Instrument Cluster Panel, Replacement	4-138
Light, Work, Replacement and Repair.	4-186
Liner, Roof, Replacement	4-458
Lines and Fittings	
Air Pressure and Accessory Air Supply, Replacement.	4-315
Air System Supply, Replacement.	4-324
Backhoe Boom Cylinder Hydraulic, Replacement	4-610
Backhoe Bucket Cylinder Hydraulic, Replacement	4-616
Backhoe Control Valve, Boom Section Hydraulic, Replacement	4-612
Backhoe Control Valve, Bucket Section Hydraulic, Replacement	4-618
Backhoe Control Valve, Swing Section Hydraulic, Replacement	4-608
Backhoe Dipper Cylinder Hydraulic, Replacement	4-614
Backhoe Stabilizer Control Valve Hydraulic, Replacement	4-604
Backhoe Swing Cylinder Hydraulic, Replacement	4-606
Backhoe/Crane Hydraulic, Replacement	4-598
Backhoe/Crane Latch Cylinder Hydraulic, Replacement	4-596
Backhoe/Crane Tilt Cylinder Hydraulic, Replacement	4-594
Brake Booster and Air Pressure, Replacement	4-318
Brake Master Cylinder Hydraulic, Replacement	4-280
Brake Pressure Regulator (ALB Valve), Replacement	4-282
Clutch Hydraulic Reservoir, Replacement	4-17
Crane External End Extension Cylinder Hydraulic, Replacement	4-632
Crane Horizontal Outrigger Cylinder Hydraulic, Replacement	4-646
Crane Inner Boom Lift Cylinder Hydraulic, Replacement	4-636
Crane Mast Locking Cylinder Hydraulic, Replacement	4-638
Crane Outer Boom Cylinder Hydraulic, Replacement	4-644
Crane Return, Replacement	4-642

Subject	Page
L (CONT)	
Crane Supply, Replacement	4-640
Crane Turntable Motor Hydraulic, Replacement	4-634
Crane Vertical Outrigger Cylinder Hydraulic, Replacement	4-648
Forklift Hydraulic, Replacement..	4-622
Forklift Lift Cylinder Hydraulic, Replacement	4-628
Forklift Pulley Hydraulic, Replacement	4-626
Forklift Rotator Cylinder Hydraulic, Replacement	4-624
Forklift Tilt Cylinder Hydraulic, Replacement	4-620
Front Brake Calipers Hydraulic, Replacement	4-284
Front Hydraulic Pump, Replacement	4-584
Front Hydraulic System Return, Replacement	4-588
Front Loader Hydraulic, Replacement	4-578
Front Loader/Forklift Control Valve Hydraulic, Replacement	4-582
Front Loader/Forklift Hydraulic, Replacement	4-580
Fuel Tank, Replacement	4-44
Hand Tool Hydraulic, Replacement.	4-586
Hydraulic Suspension Lockout Pump and Reservoir, Replacement	4-652
Hydraulic Suspension Lockout, Replacement	4-650
Left Backhoe Stabilizer Cylinder Hydraulic, Replacement	4-602
Left Loader Boom Cylinder Hydraulic, Replacement	4-569
Left Loader Bucket Rollback Cylinder Hydraulic, Replacement	4-574
Power Steering, Replacement	4-357
Protection/relay Valve, Replacement	4-320
Rear Brake Calipers Hydraulic, Replacement	4-278
Rear Hydraulic Pump, Replacement	4-590
Rear Hydraulic System Return, Replacement	4-592
Right Backhoe Stabilizer Cylinder Hydraulic, Replacement	4-600
Right Loader Boom Cylinder Hydraulic, Replacement	4-572
Right Loader Bucket Rollback Cylinder Hydraulic, Replacement	4-576
Trailer Air Supply Valve, Replacement	4-313
Trailer Air Supply, Replacement.	4-327
Trailer Emergency Air Supply, Replacement	4-310
Trailer Hand Brake Air Supply, Replacement	4-333
Trailer Hand Brake Valve, Replacement	4-329
Trailer Service Air Supply, Replacement	4-307
Lines, Fuel Injector, Replacement.	4-25
Linings, Cab Floor, Replacement.	4-454
Linkage, Accelerator, Adjustment..	4-68
Linkage, Accelerator, Replacement	4-64
Linkage, Windshield Wiper/Washer Motor, Replacement	4-479
Loader Boom Cylinder Replacement	4-654
Loader Bucket Rollback Cylinder Replacement	4-656
Loader, Front, Replacement	4-794
Low Oil Pressure and High Water Temperature Alarm Replacement	4-170
Lubrication Instructions, General.	2-22

M

Main (Master) Disconnect Switch Replacement	4-171
Maintenance Forms, Records, and Reports	1-1

Subject	Page
M (CONT)	
Manifold and Gasket, Water, Replacement	4-102
Master Light Switch Replacement.	4-137
Metric System.	1-2
Mirror, Exterior Rear View, Replacement	4-476
Mirror, Interior Rear View, Replacement	4-475
Motor Spring, Hose Reel, Replacement	4-464
Motor, Crane Hydraulic, Replacement	4-509
Motor, Windshield Wiper/Washer, Replacement	4-477
Muffler Pipes and Clamps Replacement	4-81
Muffler Replacement	4-80
O	
Oil Pressure Sender Replacement..	4-202
Oil Separator Replacement	4-6
Operator Seat and Framework Replacement	4-437
Operator Seat Framework Repair	4-442
Outlet, Coolant Water, Replacement	4-101
Outrigger, Crane Rear, Replacement	4-784
Outrigger, Forklift Front, Replacement	4-567
Outside Engine Hood Replacement.	4-388
P	
Pad, Front Disc Brake, Replacement	4-271
Pad, Rear Disc Brake, Replacement	4-268
Painting and Restenciling Markings	2-14
Parking Brake Adjustment	4-254
Parking Brake Controls Replacement	4-251
Parking Brake Switch Replacement	4-210
Passenger Seat and Framework Replacement	4-446
Pavement Breaker Hoses Replacement	4-740
Pedal and Linkage, Accelerator, Replacement	4-58
Pedal, Backhoe Swing Control, Adjustment	4-522
Pedal, Backhoe Swing Control, Replacement	4-518
Pedal, Brake, Adjustment	4-287
Pedal, Brake, Replacement	4-286
Pedal, Clutch, Replacement and Adjustment	4-13
Pintle Assembly Replacement	4-365
Pipe, Vertical Air Intake, Replacement	4-39
Pipes and Clamps, Muffler, Replacement	4-81
Plate, Chassis Tool Box/Deck, Replacement	4-364
Plate, Exhaust Manifold Screening, Replacement	4-85
Plate, Front, Replacement	4-385
Plates, Data, Replacement	4-492
Platform, Floor, Replacement	4-433
Plug, Cab Drain, Replacement..	4-414
Polarity Breaker and Suppressor Filter Mounting Bracket Replacement	4-120
Polarity Breaker Replacement	4-121
Power Steering Filter Element Replacement	4-359
Power Steering Gear Adjustment.	4-354

Subject

Page

P (CONT)

Power Steering Lines and Fittings Replacement	4-357
Power Steering Pump Belt Replacement and Adjustment	4-356
Power Steering Tank (Reservoir) Replacement	4-360
Power Take-off Indicator Switch Replacement	4-206
Pre-sediment Bowl and Filter, Fuel Filter, Replacement	4-54
Preliminary Troubleshooting Procedures	3-63
Preparation For Maintenance	2-22
Preparation For Storage Or Shipment	2-36
Press-to-Test Switch Replacement.	4-123
Preventive Maintenance Checks and Services (PMCS)	2-2
Primer, Hand, Replacement	4-31
Principles Of Operation	
Air System	1-16
Brake System	1-12
Cooling System	1-11
Earthmoving, Material Handling Components and Controls	1-14
Electrical System	1-11
Exhaust System	1-10
Fuel System	1-10
Hydraulic System	1-16
Machine (Hydraulic) Tools.	1-17
Power Train	1-9
Steering System.	1-13
Suspension	1-13
Protection/Relay Valve Lines and Fittings Replacement	4-320
Protection/Relay Valve Replacement	4-261
Pump, Front Hydraulic, Replacement	4-502
Pump, Fuel Primer, Replacement	4-29
Pump, Hydraulic Suspension Lockout, Replacement	4-511
Pump, Rear Hydraulic, Replacement	4-504
Pump, Water, Replacement	4-104
Pump, Windshield Washer, Replacement	4-484

R

Radiator Replacement	4-92
Rear Axle Final Drive Outer Seal Replacement	4-248
Rear Axle Torsion Bar Replacement	4-378
Rear Brake Calipers Hydraulic Lines and Fittings Replacement	4-278
Rear Composite Stoplight/Taillight Replacement and Repair	4-190
Rear Control Arm Replacement.	4-375
Rear Disc Brake Pad Replacement	4-268
Rear Hydraulic Pump Lines and Fittings Replacement	4-590
Rear Hydraulic Pump Replacement	4-504
Rear Hydraulic System Return Lines and Fittings Replacement	4-592
Rear Hydraulic Tank Filter Replacement	4-720
Rear Hydraulic Tank Replacement and Repair	4-712
Rear Shock Absorbers Replacement	4-372
Receptacle, Slave, Replacement	4-172
Reel Assembly, Hose, Replacement and Repair.	4-459

Subject

Page

R (CONT)

Regulator, All Wheel Drive Pressure, Replacement	4-242
Relay Replacement	4-150
Relay, Turn Signal Flasher, Replacement	4-196
Relay, Warning Delay, Replacement	4-141
Relay, Windshield Wiper/Washer Switch, Replacement	4-140
Relieving Air Pressure	2-23
Relieving Hydraulic Pressure..	2-23
Repair and Cleaning Methods, General	2-15
Repair Instructions, General	2-19
Repair Methods, General Hydraulic System	2-32
Repair Parts	2-1
Reporting Equipment Improvement Recommendations (EIRS)	1-2
Reports	1-1
Reservoir, Antifreeze, Replacement	4-298
Reservoir, Brake Fluid, Replacement	4-257
Reservoir, Clutch Hydraulic, Replacement	4-15
Reservoir, Windshield Washer, Replacement	4-483
Resistor, STE/ICE-R, Replacement	4-211
Right Backhoe Stabilizer Cylinder Hydraulic Lines and Fittings Replacement	4-600
Right Loader Boom Cylinder Hydraulic Lines and Fittings Replacement	4-572
Right Loader Bucket Rollback Cylinder Hydraulic Lines and Fittings Replacement	4-576
Rod, Tie, Adjustment	4-341
Rod, Tie, Replacement and Repair	4-338
Roof Liner Replacement.	4-458
Rotation Lock, Crane, Replacement and Adjustment	4-790
Rotor, Forklift, Replacement	4-555

S

Seal, Cab Door, Replacement.	4-413
Seal, Front Axle Final Drive Outer, Replacement	4-247
Seal, Rear Axle Final Drive Outer, Replacement	4-248
Seat and Framework, Operator, Replacement	4-437
Seat and Framework, Passenger, Replacement	4-446
Seat Belt Replacement	4-451
Seat, Backhoe, Repair	4-445
Seat, Backhoe, Replacement	4-444
Sender, Oil Pressure, Replacement	4-202
Sending Unit, Starter Lockout/Intermediate Speed Shift, Replacement	4-201
Sending Unit, Water Temperature, Replacement	4-203
Separator, Oil, Replacement	4-6
Shock Absorbers and Mountings, Cab, Replacement	4-415
Shock Absorbers, Front, Replacement (HMMH)	4-369
Shock Absorbers, Front, Replacement (SEE)	4-368
Shock Absorbers, Rear, Replacement	4-372
Shunt, STE/ICE-R, Replacement..	4-213
Sight Indicator, Hydraulic Tank, Replacement	4-719
Slave Receptacle Replacement	4-172
Small Air Pressure Tank Overflow Valve and Fittings Replacement	4-303
Solenoid, Starter, Replacement.	4-119

Subject	Page
S (CONT)	
Spare Tire and Mount Replacement (HMMH)	4-391
Spare Tire and Mount Replacement (SEE)	4-390
Special Tools, TMDE, And Support Equipment	2-1
Speedometer Drive Shaft Replacement	4-730
Speedometer Replacement	4-727
Splash Guard Replacement	4-412
Stabilizer, Backhoe, Replacement.	4-774
Start Aid, Cold, Replacement	4-55
Starter Lockout/Intermediate Speed Shift Sending Unit Replacement.	4-201
Starter Replacement	4-117
Starter Solenoid Replacement..	4-119
Starter Switch Replacement	4-133
STE/ICE-R Fuel Pressure Switch Replacement.	4-212
STE/ICE-R Resistor Replacement.	4-211
STE/ICE-R Shunt Replacement	4-213
STE/ICE-R Tachometer Drive and Cable Replacement	4-734
STE/ICE-R Troubleshooting, Engine	3-17
Steering Arm Replacement	4-349
Steering Upper Shaft Bearing Replacement	4-351
Steering Wheel Bracket and Seal Replacement	4-344
Steering Wheel Replacement	4-343
Stoplight/Taillight, Rear Composite, Replacement and Repair	4-190
Storage Or Shipment, Preparation For	2-36
Sun Visor, Clothes Hook, and Grip Handles Replacement	4-455
Support Equipment, Special Tools, and Tmde	2-1
Support, Coolant Expansion Tank, Replacement	4-97
Suppressor Filter Mounting Bracket, Polarity Breaker and, Replacement	4-120
Suppressor Filters Replacement.	4-235
Switch	
Air Cleaner Restrictor Indicator, Replacement	4-205
Auxiliary Light Control, Replacement	4-146
Auxiliary Throttle, Replacement..	4-156
Backup Alarm, Replacement	4-208
Brake Light, Replacement	4-200
Cold Start, Replacement	4-136
Differential Lock Indicator, Replacement	4-207
Engine Start, Replacement	4-199
Engine Temperature, Replacement	4-238
Hazard Warning, Replacement..	4-134
Horn, Low Beam/High Beam, Replacement	4-215
Hydraulic Oil Cooler Thermal, Replacement	4-147
Ignition, Replacement	4-131
Intermediate Speed Shift and Indicator, Replacement	4-209
Main (Master) Disconnect, Replacement	4-171
Master Light, Replacement	4-137
Parking Brake, Replacement	4-210
Power Take-off Indicator, Replacement	4-206
Press-to-Test, Replacement	4-123
Starter, Replacement	4-133
STE/ICE-R Fuel Pressure, Replacement	4-212

Subject	Page
S (CONT)	
Throttle Control, Replacement (HMMH)	4-158
Throttle Control, Replacement (SEE).	4-154
Windshield Heater Control, Replacement	4-139
Windshield Wiper/Washer, Replacement	4-132
Switches, Bucket and Auxiliary Throttle, Replacement	4-151
Switches, Tool and Work Light, Replacement	4-162
Symptom Index, Troubleshooting.	3-65
T	
Tachometer Drive and Cable, STE/ICE-R, Replacement	4-734
Tachometer Replacement	4-128
Tandem Valve Replacement	4-322
Tank (Reservoir), Power Steering, Replacement	4-360
Tank, Coolant Expansion, Replacement	4-96
Tank, Front Hydraulic, Replacement and Repair	4-702
Tank, Fuel, Draining	4-40
Tank, Fuel, Replacement	4-42
Tank, Rear Hydraulic, Replacement and Repair.	4-712
Tanks, Air Pressure, Replacement	4-288
Test Equipment, Electrical	3-1
Thermostat, Coolant, Replacement	4-100
Three-point Stance (HMMH)	2-23
Three-point Stance (SEE)	2-22
Throttle Control Switch Replacement (HMMH)	4-158
Throttle Control Switch Replacement (SEE)	4-154
Throttle, Hand, Replacement	4-70
Tie Rod Adjustment	4-341
Tie Rod Replacement and Repair	4-338
Tire and Mount, Spare, Replacement	4-391
Tire and Mount, Spare, Replacement	4-390
Tire Replacement	4-337
Tool and Work Light Switches Replacement	4-162
Tools and Equipment, Common.	2-1
Tooth, Backhoe Bucket/Ripper, Replacement	4-766
Tooth, Front Loader Bucket, Replacement	4-804
Torque Value Instructions, General	2-22
Torsion Bar, Front Axle, Replacement	4-376
Torsion Bar, Rear Axle, Replacement	4-378
Tower, Backhoe Control, Replacement	4-404
Tower, Backhoe Swing, Replacement	4-772
Towing Vehicle	
(HMMH)	2-29
(SEE)	2-26
Tractor Protection Valve Replacement	4-332
Trailer Air Supply Lines and Fittings Replacement	4-327
Trailer Air Supply Valve Lines and Fittings Replacement	4-313
Trailer Air Supply Valve Replacement	4-331
Trailer Connection Replacement	4-230
Trailer Emergency Air Supply Lines and Fittings Replacement	4-310

Subject	Page
T (CONT)	
Trailer Hand Brake Air Supply Lines and Fittings Replacement	4-333
Trailer Hand Brake Valve Lines and Fittings Replacement	4-329
Trailer Hand Brake Valve Replacement	4-326
Trailer Service Air Supply Lines and Fittings Replacement	4-307
Travel Lock, Backhoe, Replacement and Repair	4-678
Travel Lock, Backhoe, Replacement and Repair	4-681
Travel Lock, Crane, Replacement and Adjustment	4-786
Travel Lock, Forklift, Replacement.	4-566
Trigger, Guard, and Handle Bar, Chain Saw, Replacement	4-746
Troubleshooting	
Air Intake System	3-86
Backhoe (SEE).	3-298
BR67 Pavement Breaker (SEE)...	3-296
Brakes and Air System	3-267
Chain Saw (SEE)	3-296
Cooling System	3-87
Crane (HMMH)	3-309
Electrical System	3-88
Engine	3-70
Exhaust System	3-86
Forklift (HMMH)	3-284
Front Loader (SEE)	3-315
HD45 Hammer Drill (SEE)	3-292
Hydraulic System	3-282
Impact Wrench (HMMH)	3-294
Steering	3-277
Suspension	3-280
Transmission	3-264
Troubleshooting Procedures, Preliminary.	3-63
Troubleshooting, Electrical	3-64
Troubleshooting, Using STE/ICE-R, Engine.	3-17
Tube Fittings Replacement	2-25
Tubes, Defroster and Air, Replacement	4-486
Turn Signal Flasher Relay Replacement	4-196
Turn Signal Lever Replacement.	4-122
V	
Valve Adjustment	4-5
Valve and Fittings, Accessory Air Supply Overflow, Replacement.	4-304
Valve and Fittings, Large Air Pressure Tank Overflow, Replacement	4-302
Valve and Fittings, Small Air Pressure Tank Overflow, Replacement	4-303
Valve Cover and Gasket Replacement	4-3
Valve, All Wheel Drive Selector, Replacement	4-240
Valve, Fluid Regulating, Replacement	4-306
Valve, Front Loader Hydraulic Relief, Replacement.	4-568
Valve, Protection/relay, Replacement	4-261
Valve, Tandem, Replacement	4-322

Subject	Page
W	
Valve, Tractor Protection, Replacement	4-332
Valve, Trailer Air Supply, Replacement	4-331
Valve, Trailer Hand Brake Valve, Replacement	4-326
Vertical Air Intake Pipe Replacement	4-39
Warning Delay Relay Replacement	4-141
Warranty Information	1-2
Water Manifold and Gasket Replacement	4-102
Water Pump Replacement	4-104
Water Temperature Sending Unit Replacement	4-203
Wheel Assembly Replacement..	4-335
Wheel, Steering, Replacement..	4-343
Windshield Heater Control Switch Replacement	4-139
Windshield Washer Pump Replacement	4-484
Windshield Washer Reservoir Replacement	4-483
Windshield Wiper Replacement.	4-482
Windshield Wiper/Washer Motor Linkage Replacement	4-479
Windshield Wiper/Washer Motor Replacement	4-477
Windshield Wiper/Washer Switch Relay Replacement	4-140
Windshield Wiper/Washer Switch Replacement	4-132
Wiper, Windshield, Replacement.	4-482
Wiring Harness and Wire Repair	3-11
Wiring Harness, Front Disc Brake Pad Indicator, Replacement	4-231
Work Light Replacement and Repair	4-186

By Order of the Secretary of the Army:

GORDON R. SULLIVAN
General, United States Army
Chief of Staff

Official:

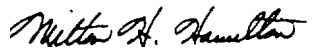

MILTON H. HAMILTON
Administrative Assistant to the
Secretary of the Army

04677

Distribution:

To be distributed in accordance with DA Form 12-38-E (Block 0973) requirements for TM5-2420-224-20-1.

* US GOVERNMENT PRINTING OFFICE: 1993 -746 -017/ 80223



THEN... JOT DOWN THE DOPE ABOUT IT ON THIS FORM. CAREFULLY TEAR IT OUT. FOLD IT AND DROP IT IN THE MAIL!

SOMETHING WRONG WITH THIS PUBLICATION?

FROM: (PRINT YOUR UNIT'S COMPLETE ADDRESS)

Your mailing address

DATE SENT

Date you filled out this form

PUBLICATION NUMBER

TM 5-2420-224-20-1

PUBLICATION DATE

Date of TM

PUBLICATION TITLE

SEE and HMMH
Unit Maintenance Manual

BE EXACT... PIN-POINT WHERE IT IS

PAGE NO	PARA-GRAPH	FIGURE NO.	TABLE NO
3-86			

IN THIS SPACE TELL WHAT IS WRONG AND WHAT SHOULD BE DONE ABOUT IT:

MALFUNCTION 12, STEP 2. CHANGE PAGE REFERENCE TO PAGE 4-206

SAMPLE

PRINTED NAME, GRADE OR TITLE, AND TELEPHONE NUMBER

SIGN HERE:



THEN... JOT DOWN THE DOPE ABOUT IT ON THIS FORM. CAREFULLY TEAR IT OUT. FOLD IT AND DROP IT IN THE MAIL!

SOMETHING WRONG WITH THIS PUBLICATION?

FROM: (PRINT YOUR UNIT'S COMPLETE ADDRESS)

DATE SENT

PUBLICATION NUMBER

TM 5-2420-224-20-1

PUBLICATION DATE

28 Jul 93

PUBLICATION TITLE SEE and HMMH
Unit Maintenance Manual

BE EXACT... PIN-POINT WHERE IT IS

PAGE NO	PARA-GRAPH	FIGURE NO.	TABLE NO

IN THIS SPACE TELL WHAT IS WRONG AND WHAT SHOULD BE DONE ABOUT IT:

PRINTED NAME, GRADE OR TITLE, AND TELEPHONE NUMBER

SIGN HERE:

REVERSE OF DA FORM 2028-2

REVERSE OF DA FORM 2028-2

FILL IN YOUR
UNIT'S ADDRESS

FOLD BACK

DEPARTMENT OF THE ARMY

OFFICIAL BUSINESS

Commander
US Army Tank-Automotive Command
ATTN: AMSTA-MB
Warren, Michigan 48397-5000

TEAR ALONG PERFORATED LINE

THE METRIC SYSTEM AND EQUIVALENTS

LINEAR MEASURE

1 Centimeter = 10 Millimeters = 0.01 Meters = 0.3937 Inches
 1 Meter = 100 Centimeters = 1,000 Millimeters = 39.37 Inches
 1 Kilometer = 1,000 Meters = 0.621 Miles

WEIGHTS

1 Gram = 0.001 Kilograms = 1,000 Milligrams = 0.035 Ounces
 1 Kilogram = 1,000 Grams = 2.2 Lb
 1 Metric Ton = 1,000 Kilograms = 1 Megagram = 1.1 Short Tons

LIQUID MEASURE

1 Milliliter = 0.001 Liters = 0.0338 Fluid Ounces
 1 Liter = 1,000 Milliliters = 33.82 Fluid Ounces

SQUARE MEASURE

1 Sq Centimeter = 100 Sq Millimeters = 0.155 Sq Inches
 1 Sq Meter = 10,000 Sq Centimeters = 10.76 Sq Feet
 1 Sq Kilometer = 1,000,000 Sq Meters = 0.386 Sq Miles

CUBIC MEASURE

1 Cu Centimeter = 1,000 Cu Millimeters = 0.06 Cu Inches
 1 Cu Meter = 1,000,000 Cu Centimeters = 35.31 Cu Feet

TEMPERATURE

$5/9 (^{\circ}\text{F} - 32) = ^{\circ}\text{C}$
 212° Fahrenheit is equivalent to 100° Celsius
 90° Fahrenheit is equivalent to 32.2° Celsius
 32° Fahrenheit is equivalent to 0° Celsius
 $9/5 \text{ C} + 32 = \text{F}$

APPROXIMATE CONVERSION FACTORS

TO CHANGE	TO	MULTIPLY BY
Inches	Centimeters	2.540
Feet	Meters	0.305
Yards	Meters	0.914
Miles	Kilometers	1.609
Square Inches	Square Centimeters	6.451
Square Feet	Square Meters	0.093
Square Yards	Square Meters	0.836
Square Miles	Square Kilometers	2.590
Acres	Square Hectometers	0.405
Cubic Feet	Cubic Meters	0.028
Cubic Yards	Cubic Meters	0.765
Fluid Ounces	Milliliters	29.573
Pints	Liters	0.473
Quarts	Liters	0.946
Gallons	Liters	3.785
Ounces	Grams	28.349
Pounds	Kilograms	0.454
Short Tons	Metric Tons	0.907
Pound-Feet	Newton-Meters	1.356
Pounds Per Square Inch	Kilopascals	6.895
Miles Per Gallon	Kilometers Per Liter	0.425
Miles Per Hour	Kilometers Per Hour	1.609

TO CHANGE	TO	MULTIPLY BY
Centimeters	Inches	0.394
Meters	Feet	3.280
Meters	Yards	1.094
Kilometers	Miles	0.621
Square Centimeters	Square Inches	0.155
Square Meters	Square Feet	10.764
Square Meters	Square Yards	1.196
Square Kilometers	Square Miles	0.386
Square Hectometers	Acres	2.471
Cubic Meters	Cubic Feet	35.315
Cubic Meters	Cubic Yards	1.308
Milliliters	Fluid Ounces	0.034
Liters	Pints	2.113
Liters	Quarts	1.057
Liters	Gallons	0.264
Grams	Ounces	0.035
Kilograms	Pounds	2.205
Metric Tons	Short Tons	1.102
Newton-Meters	Pound-Feet	0.738
Kilopascals	Pounds Per Square Inch	0.145
Kilometers Per Liter	Miles Per Gallon	2.354
Kilometers Per Hour	Miles Per Hour	0.621

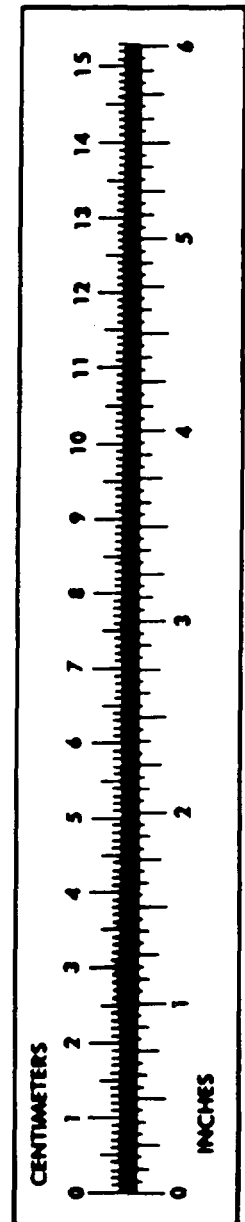

PIN: 068064-000